



ASSEMBLY APP AVAILABLE ON  + 

We highly recommend downloading the Absco Sheds Assembly App to assist with your build.



STEP BY STEP ASSEMBLY VIDEOS • PARTS CHECKLISTS • FAQ • 7 DAY CUSTOMER SERVICE • WARRANTY INFORMATION

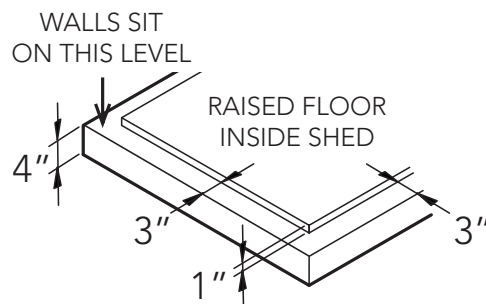
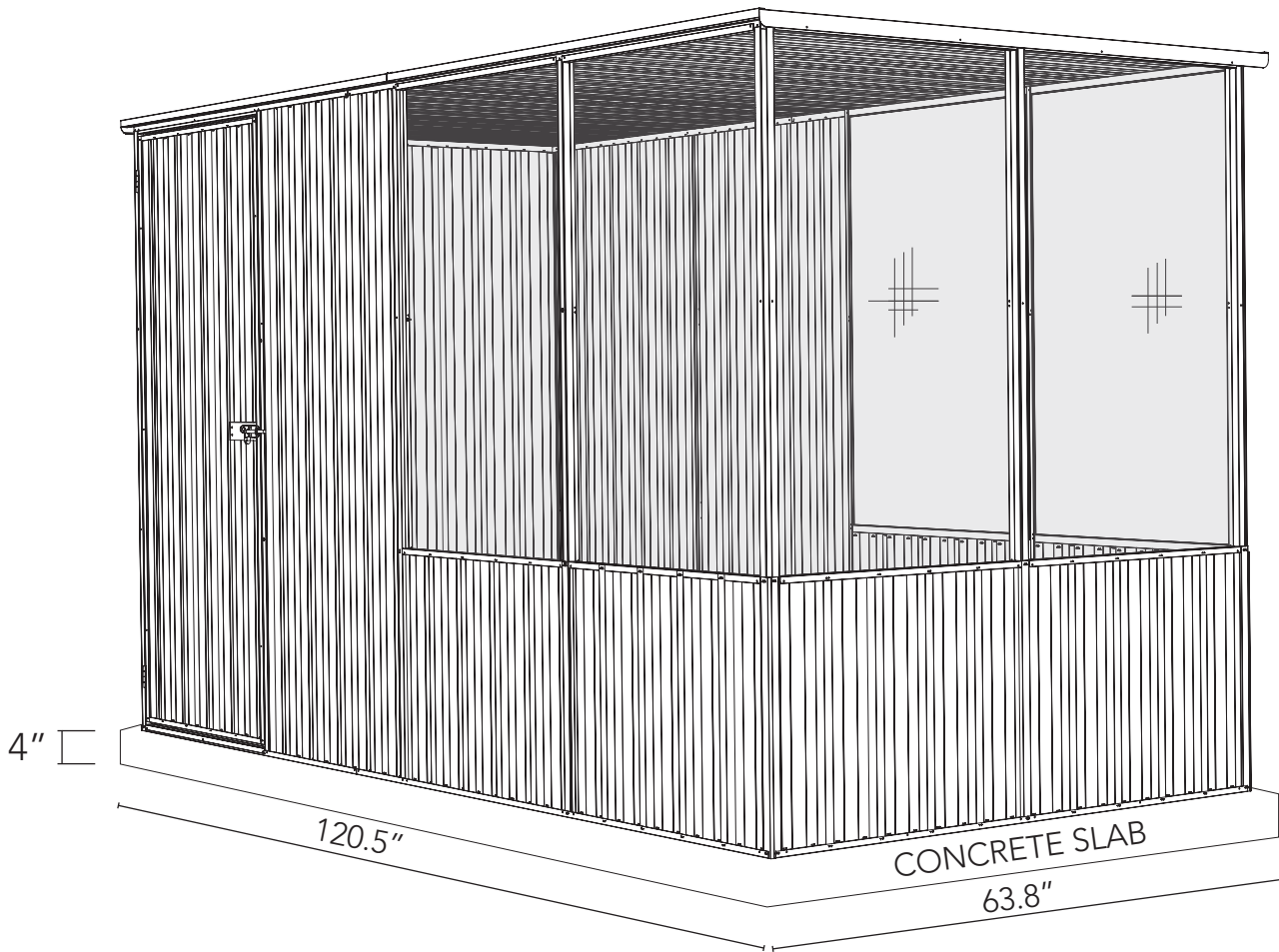

Overall slab base dimensions for this model are as shown above.

Illustration not to scale.

When laying a concrete slab for your shed, it is best practise to have a rebated edge to prevent water ingress.

Rebated section is 1" high and inset 3" on all sides from the overall slab base dimensions



GENERAL INSTRUCTIONS

- Before commencing any assembly, read through these instructions in detail to gain a thorough understanding of assembly methods and associated details.
- Unpack the carton and carefully identify and check off all the parts against the parts described and illustrated on "COMPONENTS PACKING LIST" pages.

SITE PREPARATION

- The site for the shed must be level. An uneven surface may result in misalignment of parts.
- The shed shall be erected on top of a reinforced concrete slab and anchored down appropriately illustrated on "FINAL CONSTRUCTION" page.

SAFETY NOTES

- Some parts may have sharp edges. It is advisable to wear gloves when handling these items and safety glasses if drilling holes. Sensible shoes are highly recommended.
- Do not erect your shed in windy conditions.
- Ensure that the shed is securely anchored to a solid foundation immediately after construction is completed.
- It is highly recommended to erect the shed with two or more people.
- Do not sit, stand or walk on the roof of your shed.

RECOMMENDED



Personal protective equipment for tools



Hand Protection



Enclosed Shoes



Raised work surface. EG Sawhorses and timbers



Heavy and/or bulky. Multi-person lift or mechanical aid.

TOOLS REQUIRED

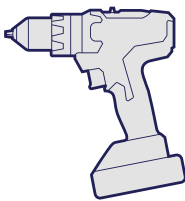

Cordless drill

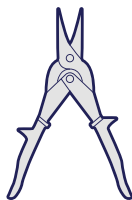

Tinsnips

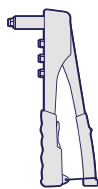

Pop riveter
SUPPLIED



Ladder

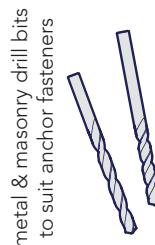

metal & masonry drill bits
to suit anchor fasteners

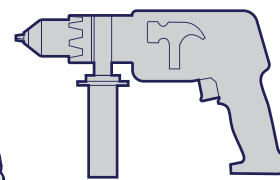

Hammer drill



Shifter

NUMBER OF PEOPLE REQUIRED



2 people

NUMBER OF HOURS REQUIRED



Approx. 7 hours

ASSEMBLY DIFFICULTY







Basic

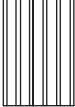
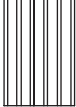
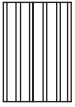
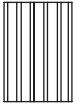
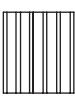
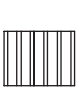
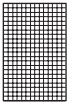
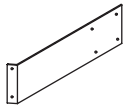

Complex

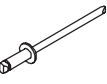
COMPONENT PACKING LIST

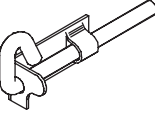
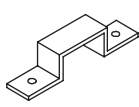

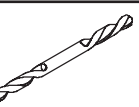
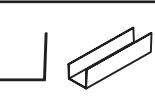
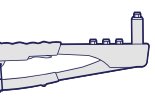



Check off all components.

SHEETING							
QTY	COMPONENT DESCRIPTION	PART No.	CHK	QTY	COMPONENT DESCRIPTION	PART No.	CHK
2	 STEEL SHEET 70.3" x 30.4"	30A		2	 STEEL SHEET 70.3" x 28.8"	33A	
1	 STEEL SHEET 70.3" x 30.4"	30G		1	 STEEL SHEET 67.9" x 28"	37A	
4	 STEEL SHEET 62.6" x 30.4"	46A		6	 STEEL SHEET 23.6" x 30.4"	31D	
6	 MESH SHEET 47" x 27.7"	MESH20					
FITTINGS PACK							
1	 DOOR PLATE	12A		1	 8G x 3/8" SELF TAPPING SCREW PACK QTY 220	FAST001	
20	 POP RIVET	FAST009		15	 8G x 3/4" SELF TAPPING SCREW	FAST013	
1	 PADBOLT	FAST006		1	 PADBOLT HASP	FAST007	
6	 3/16 x 1/2" CSK SCREW & NUT	FAST004 FAST005		1	 PHILLIPS HD DRIVER BIT	FAST038	
1	 1/8" DRILL BIT	DRILL		6	 CHANNEL JOINER	CSJ	
1	 HAND POP RIVETER	RIVET GUN					

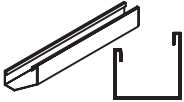
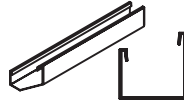
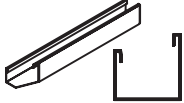
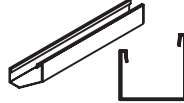
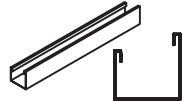
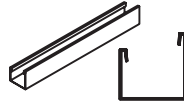
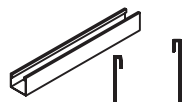
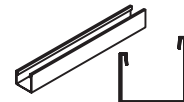
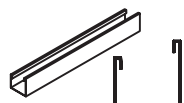
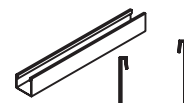
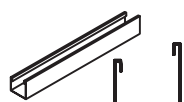

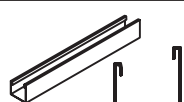
COMPONENT PACKING LIST

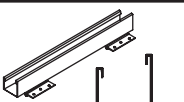
Check off all components.

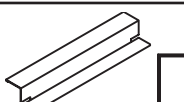
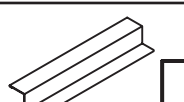
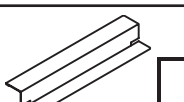
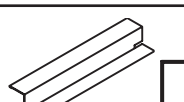
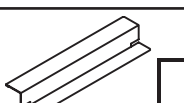
CHANNEL PACK							
QTY	COMPONENT DESCRIPTION	PART No.	CHK	QTY	COMPONENT DESCRIPTION	PART No.	CHK
3	 CHANNEL 70.3"	80L		1	 CHANNEL 59.5"	81F	
1	 CHANNEL 59.5"	53C		2	 CHANNEL 58.6"	53T	
2	 CHANNEL 48.5"	313L		2	 CHANNEL 67.2"	313R	
2	 CHANNEL 67.2"	314L		2	 CHANNEL 48.5"	314R	
2	 CHANNEL 58.9"	81AL		2	 CHANNEL 58.9"	81AR	
2	 CHANNEL 28"	58M		12	 CHANNEL 28"	181	
1	 CHANNEL 67.9"	58B		1	 CHANNEL 28.3"	54G	
1	 CHANNEL 67.9"	58A		2	 LIP TRIM 46"	88A	
12	 JAMB 70.3"	70D		2	 JAMB 42.5"	91E	
1	 JAMB 70.3"	89A		1	 JAMB 70.3"	89B	
1	 JAMB 28.3"	91D					



SNAPTITE ASSEMBLY GUIDE

The Snaptite Assembly System locks end channels to all roof and wall sheets without the need for tools and fasteners.

To assemble each panel, the perimeter channels are secured to the top and bottom of each panel. Gently tap the channel over the SNAPTITE lugs on the sheet, working along the sheet.

Each perimeter channel must finish flush with the edges of the sheets. Simply tap the channel along the sheets until each end is neatly flush. If you need to remove channels from the panels, slide it off from the side.

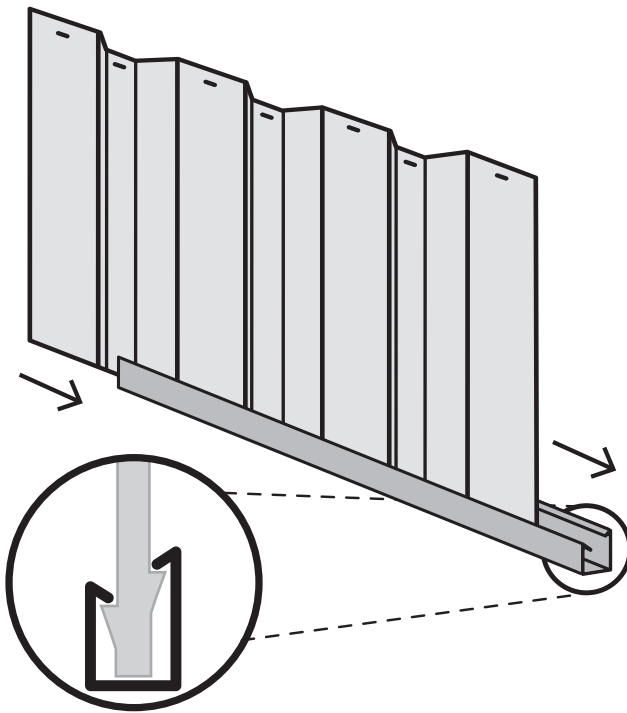

SNAPTITE
World's Easiest Assembly System
UNIQUE PATENTED SYSTEM

Channel locks the shed panel into position without the need for screws!

FASTENING SYMBOLS

 SNAPTITE

Secure channel to sheeting by SNAPTITE fastening method.



Join components together with one screw at this location only, as some channels have extra holes that are not required for this model of shed.



Do not join components together at this location yet, as the screws may obstruct further assembly of the other components.



Join components together by pre-drilling the holes first. Use one component as template to mark where the holes are and drill with a 1/8" drill bit.



1/8" pop rivet



3/16" nut and bolt set.

Guide on Joining Spliced Channels

The text marked on all parts must be shown on the same side as each other



Step 1.
Position the channels and the CSJ joiner so the centre of the CSJ is in line with the end of each channel to be joined together.

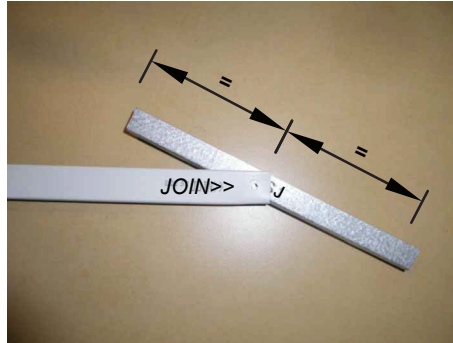

Step 2.
Join the first channel to the CSJ by inserting the centre of the CSJ, on an angle, to the end of the channel where the JOIN>> text is marked.

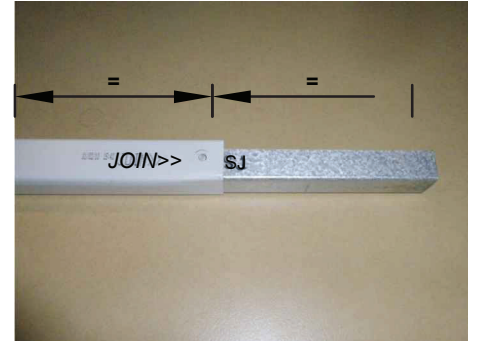

Push down one side of the CSJ until you hear a 'click'.

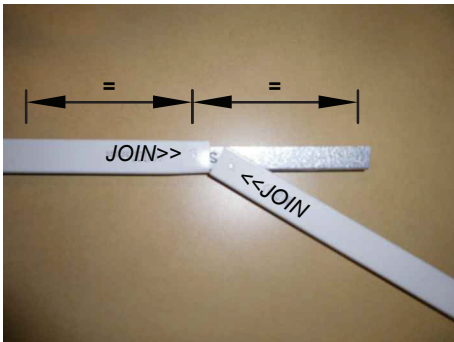

Step 3.
Join the second channel to the CSJ by positioning the <<JOIN of the channel at the centre of the CSJ, on an angle. Push the CSJ into the channel until you hear a 'click'.

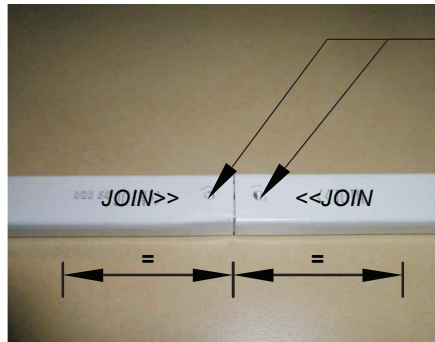

Finished Channel.
The joined channels should now look like the picture with the CSJ positioned equally inside of the joined channels.

Drill out holes with 1/8" drill bit in CSJ to match the holes in channel. Drilling of screws on the joined channels is being done after sheets are locked on the spliced channels.

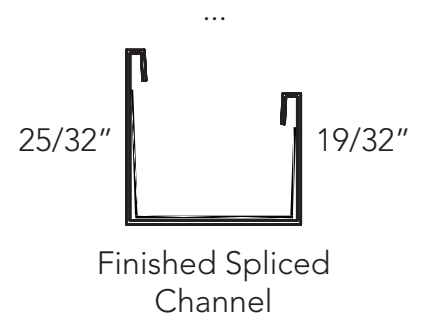
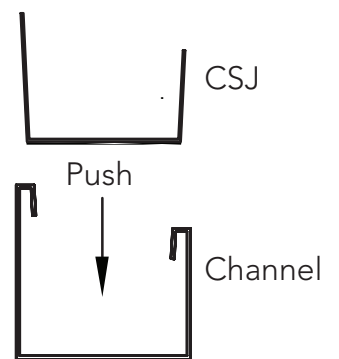

PRE-ASSEMBLY OF SPLICED CHANNELS

Join together 12 x channel sections using 6 x channel joiners (Part CSJ)

NOTE: Some channels may have holes in them - You will need to redrill holes where CSJ joining channel covers them.

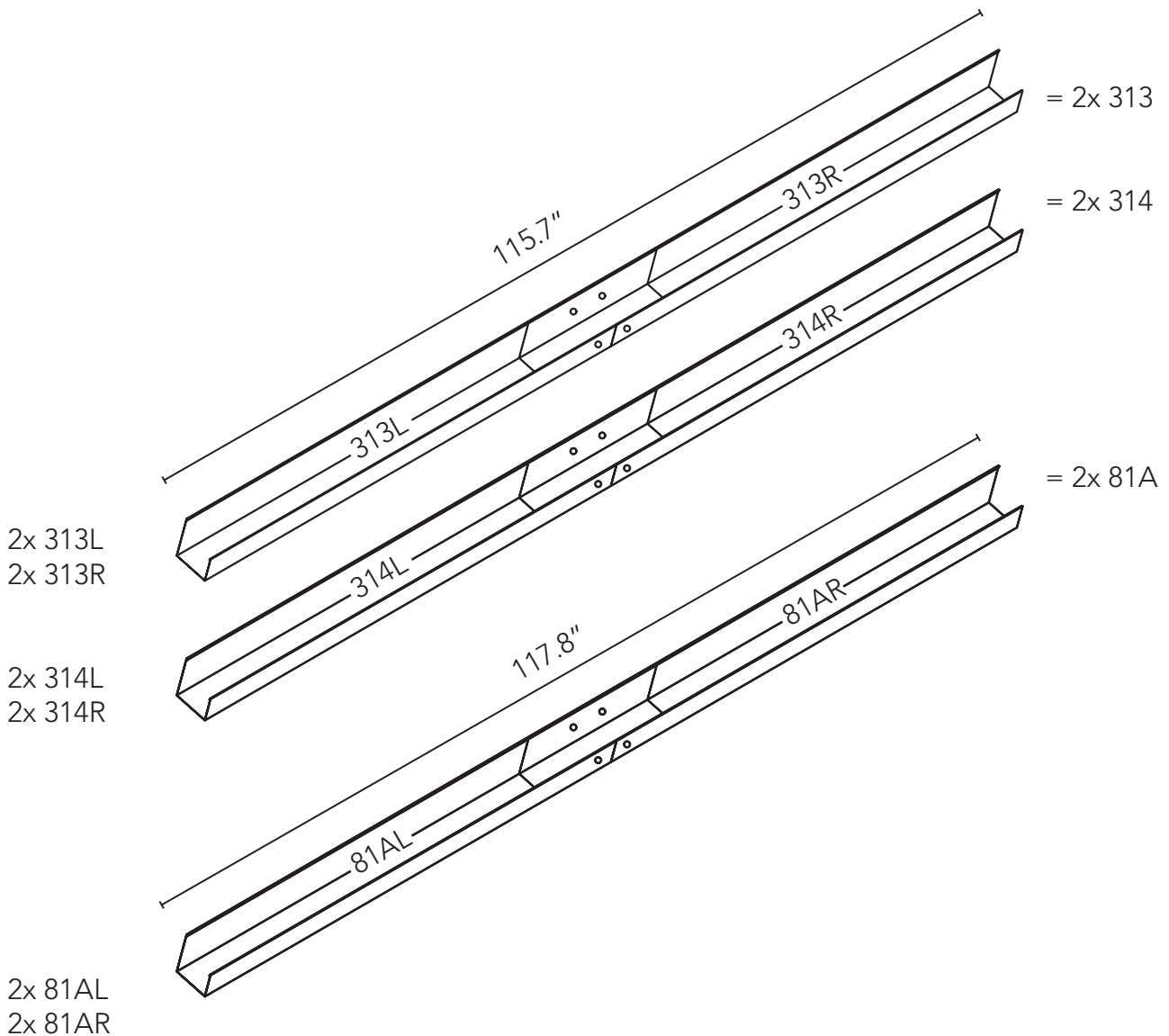



ROOF AND WALL OVERVIEW

Mesh panels not shown for illustrative purposes.

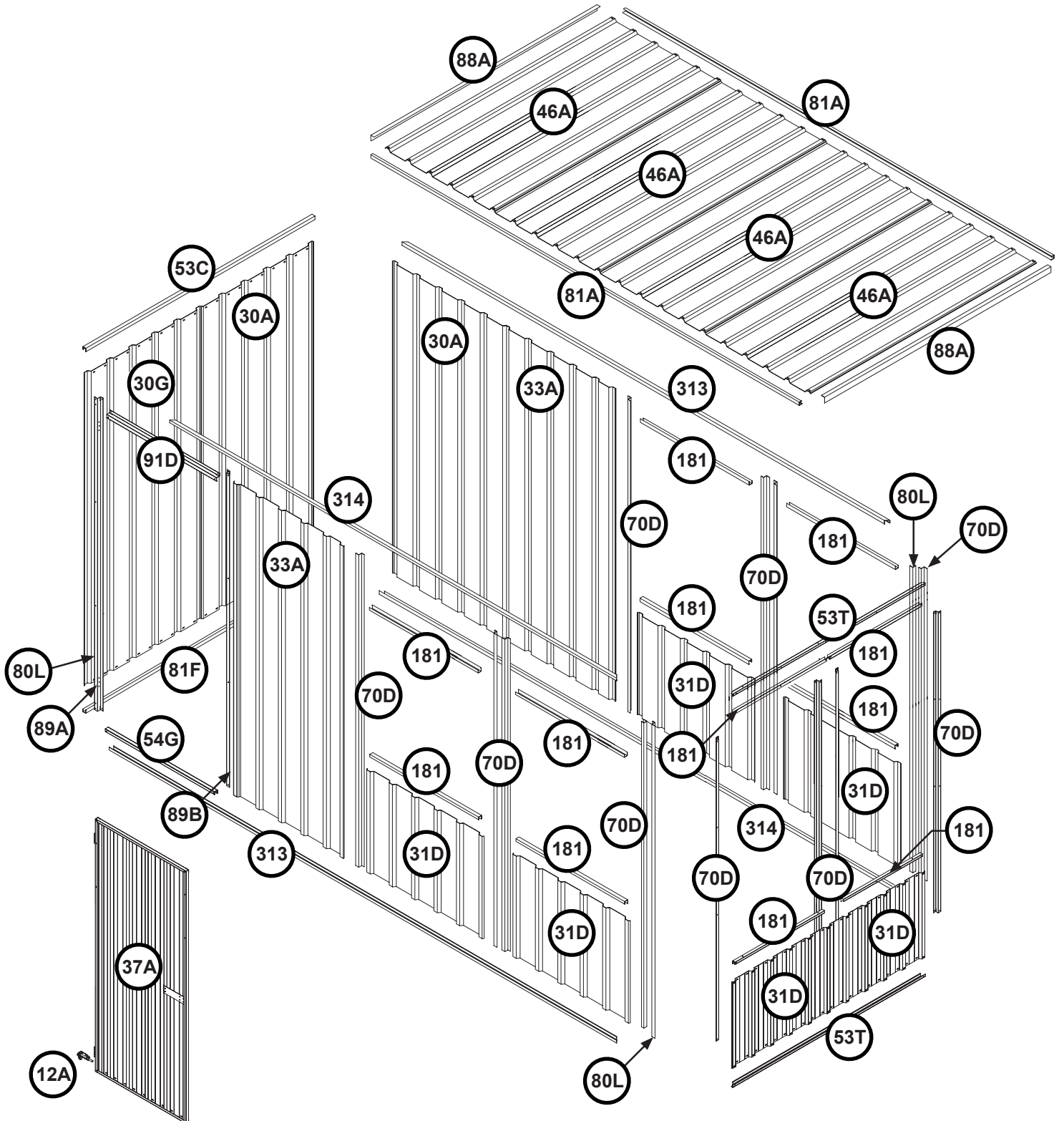

REAR PANEL ASSEMBLY

1x required

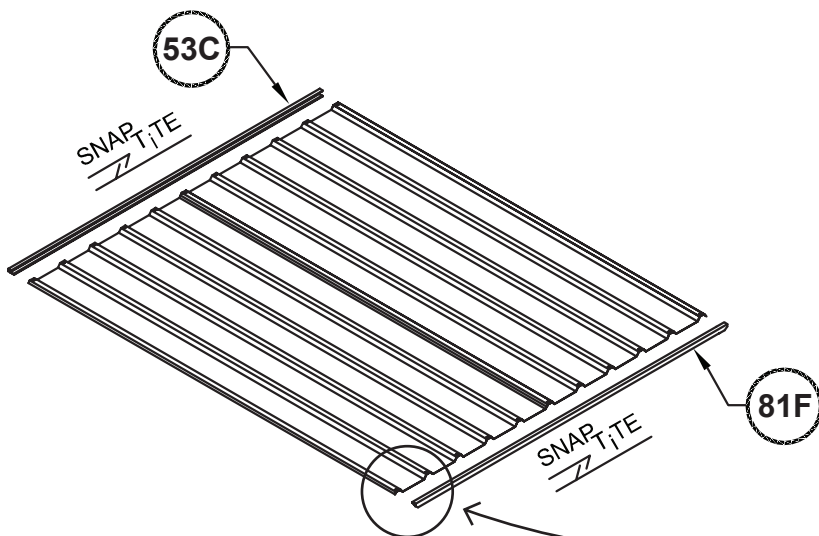
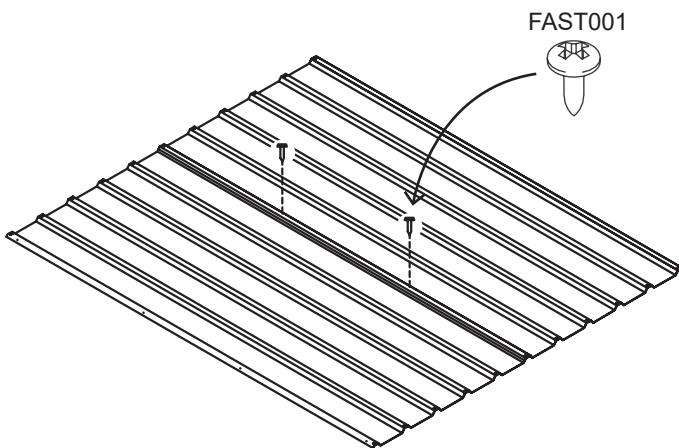
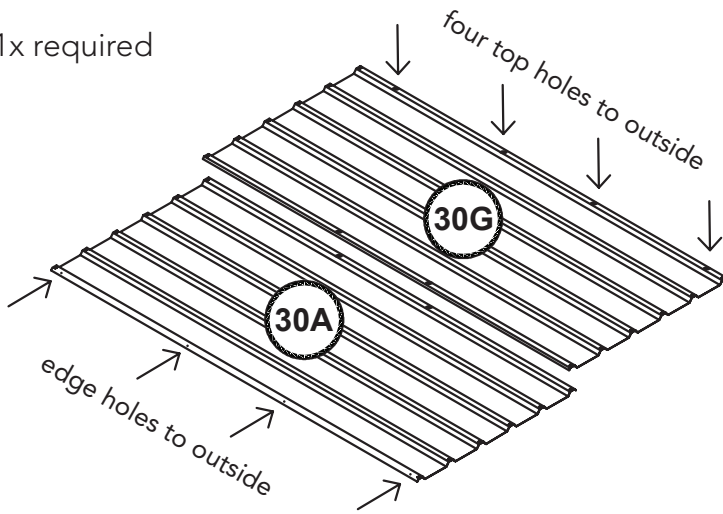

1. Overlap specified sheets by a rib.

Make sure ends are flush and orientated as shown.

2. Fasten with self tapping screws through prepunched sheet-to-sheet holes on overlap.

If you can't see bottom hole twist the sheet left or right.

Make a new hole with supplied drill bit if bottom hole is too far up or down the sheet or not found.

3. Attach the top and bottom channels using the SNAP-TiTE method.

Make sure you have the short side of the channel to the outside of the sheeting

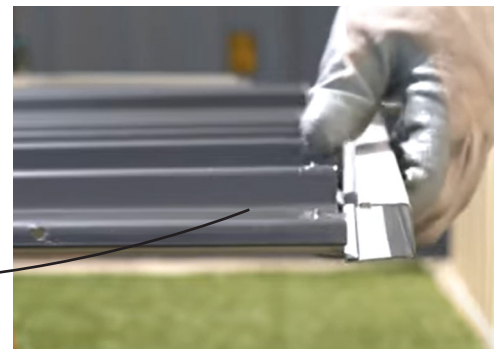

ROOF PANEL

1x required

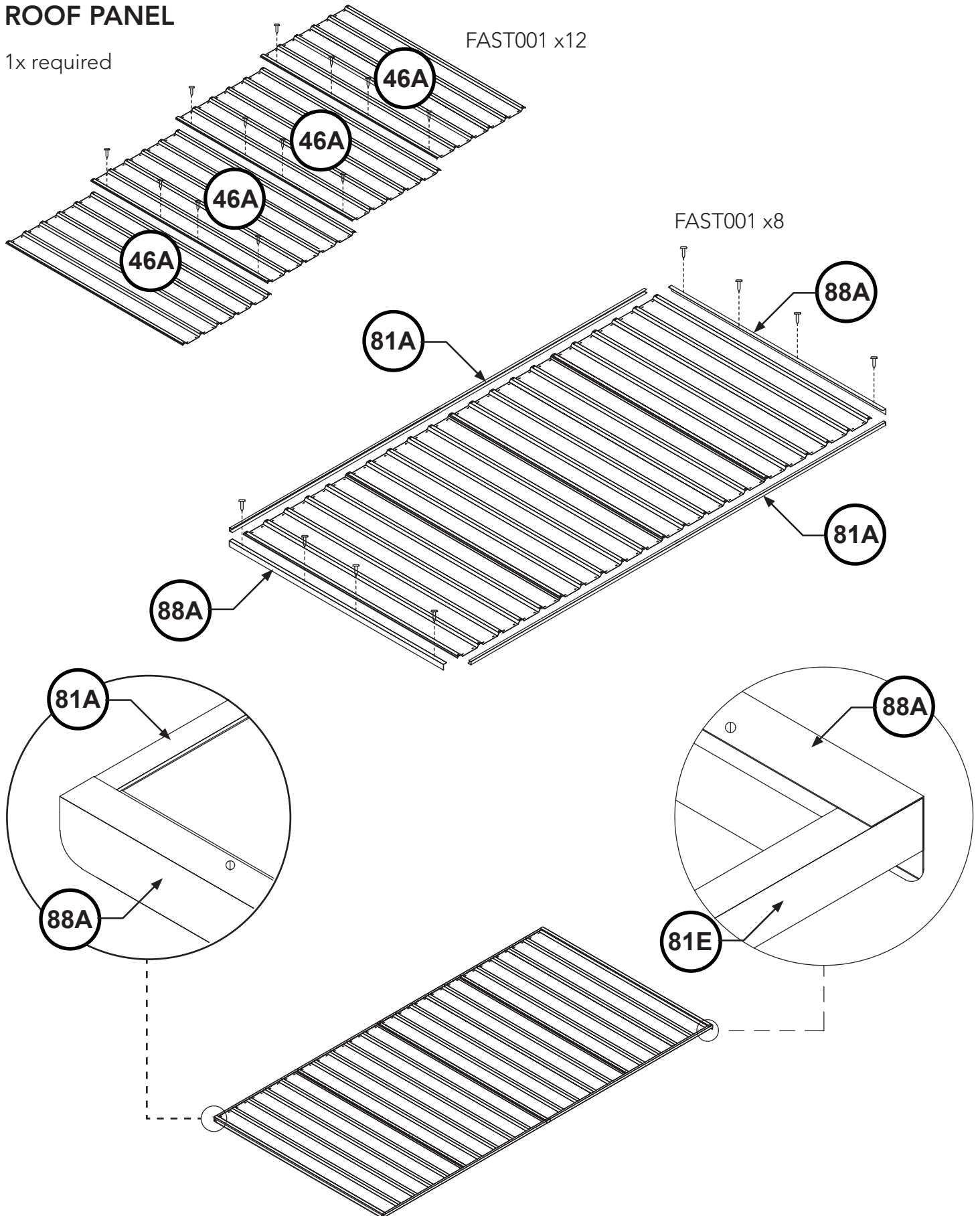

RIGHT SIDE PANEL

1x required

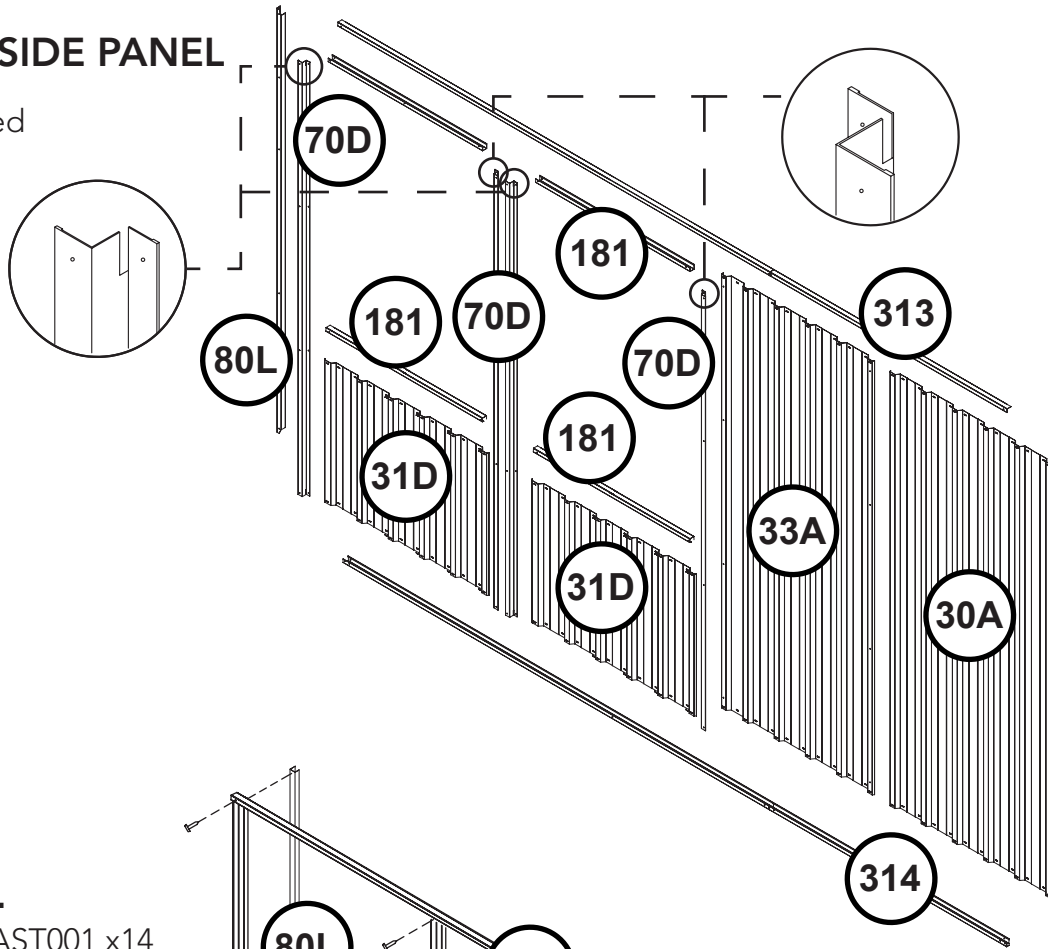

1.
FAST001 x14

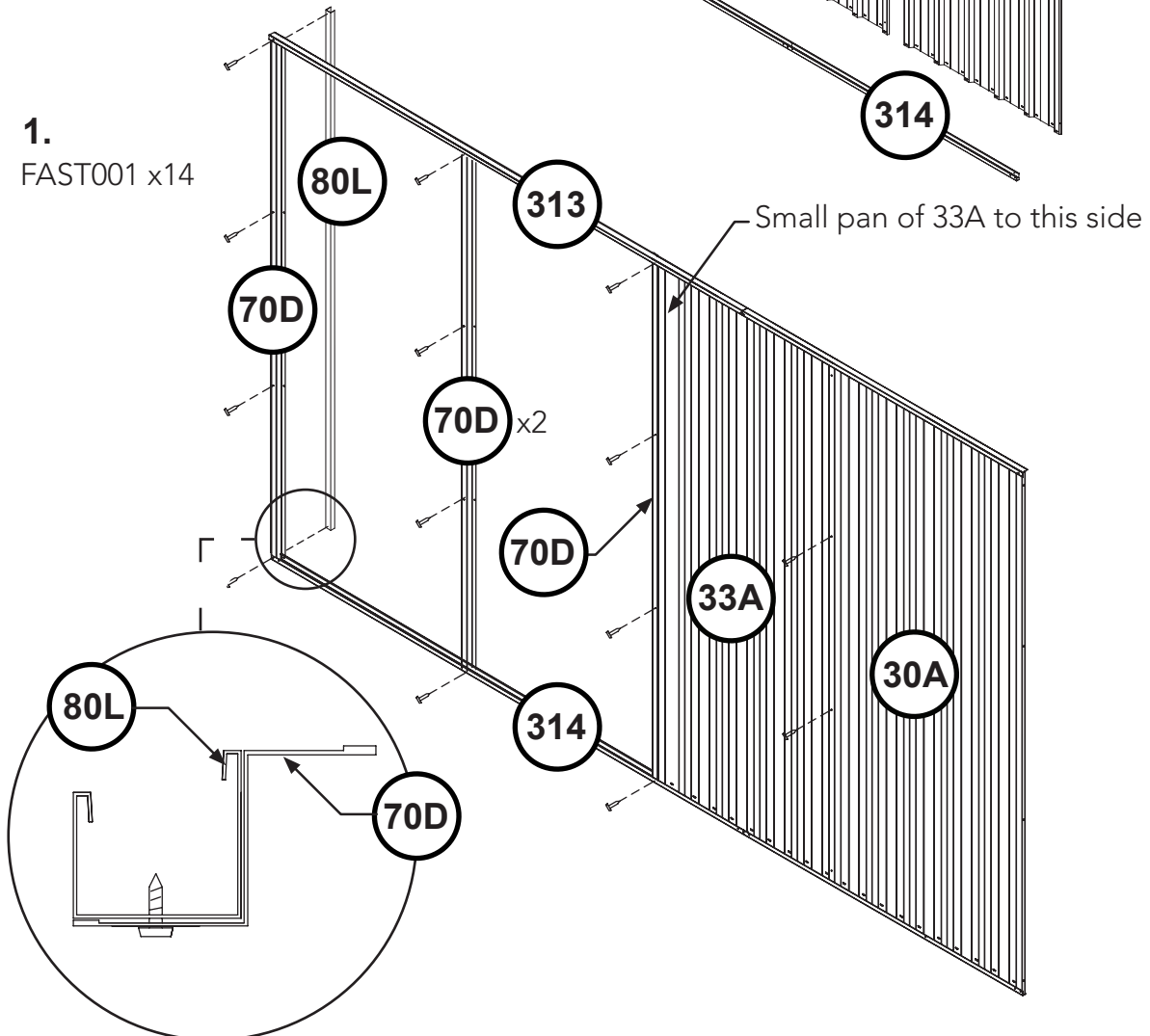

RIGHT SIDE PANEL

2.

Prepare two short sheets

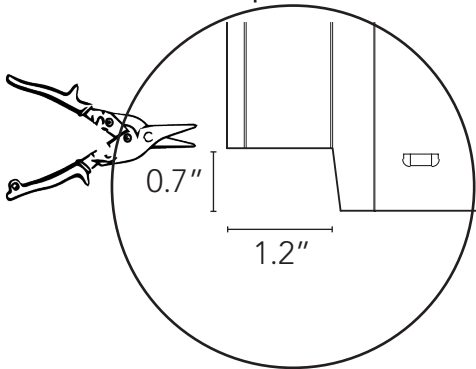
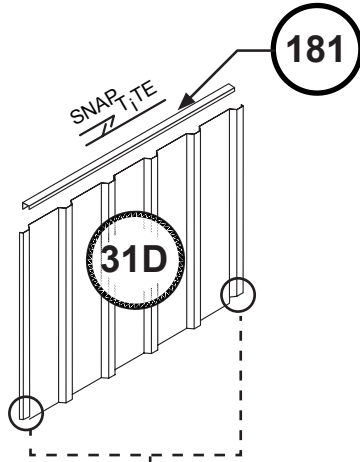

Notch out both bottom corners as shown using tinsnips.

3.

FAST001 x4

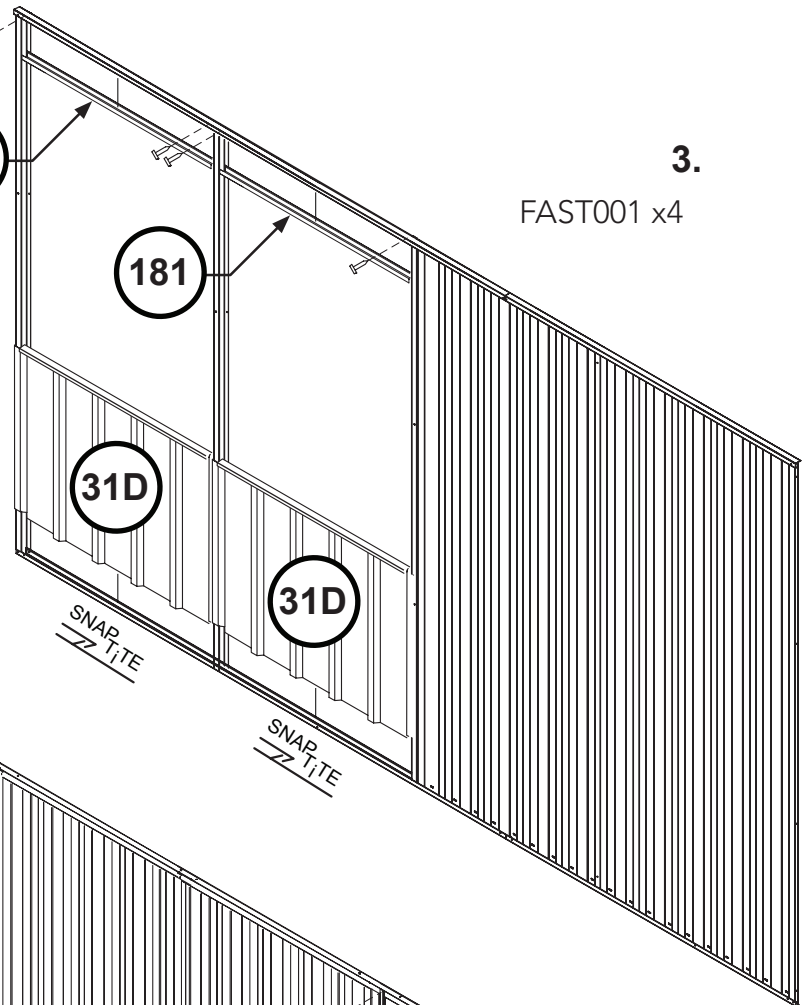

4.

FAST001 x 4
FAST009 x 8

Use rivets in the corners of the window openings. You may need to drill through aligned holes with supplied bit to allow a better fit for the rivet head.

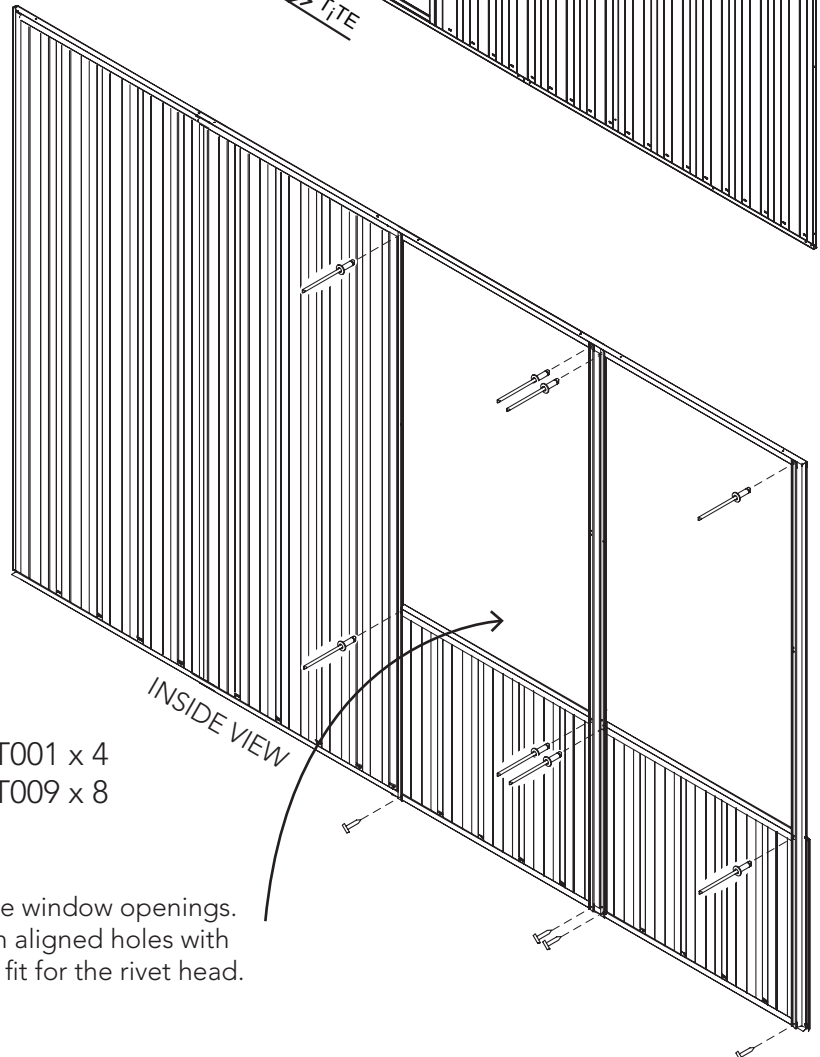

LEFT SIDE PANEL

1x required

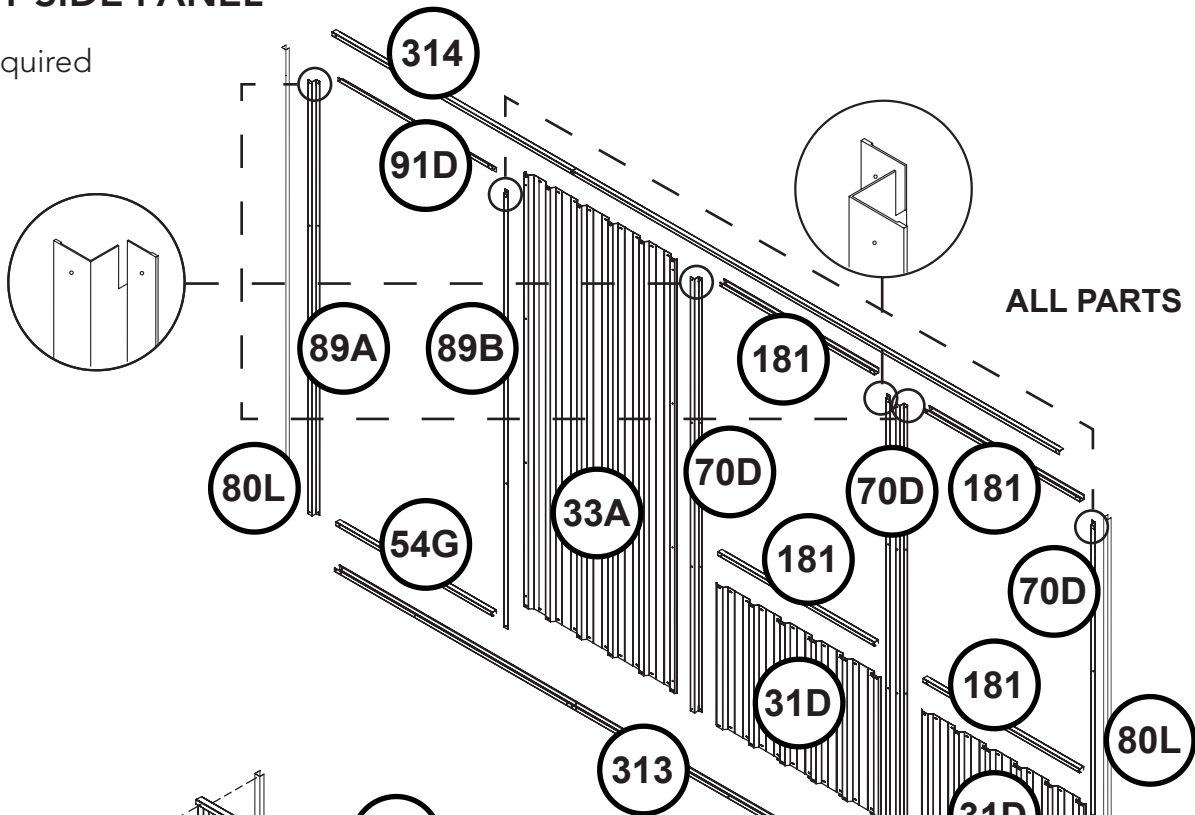

ALL PARTS

1.
FAST001 x20

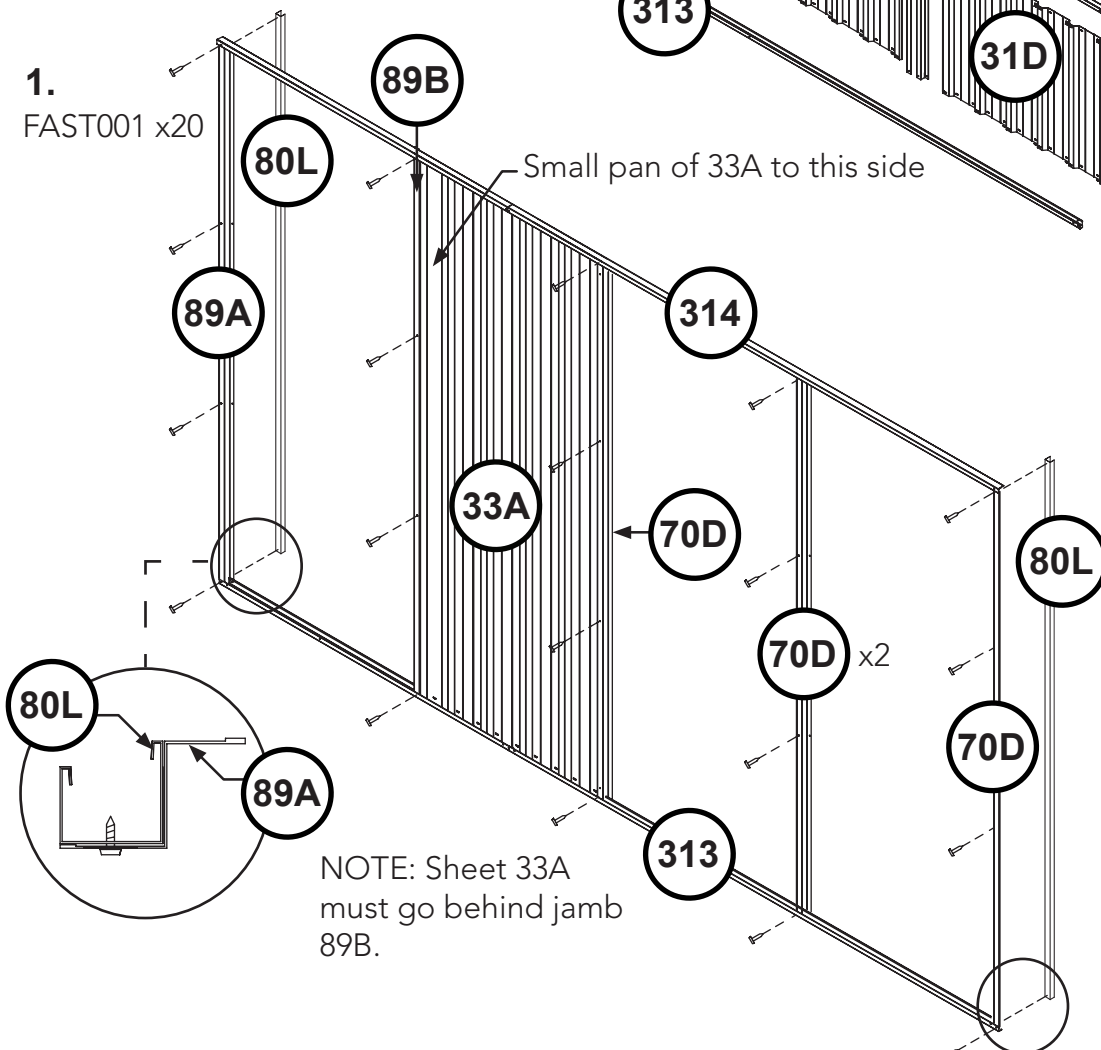

LEFT SIDE PANEL

2.

Prepare two short sheets

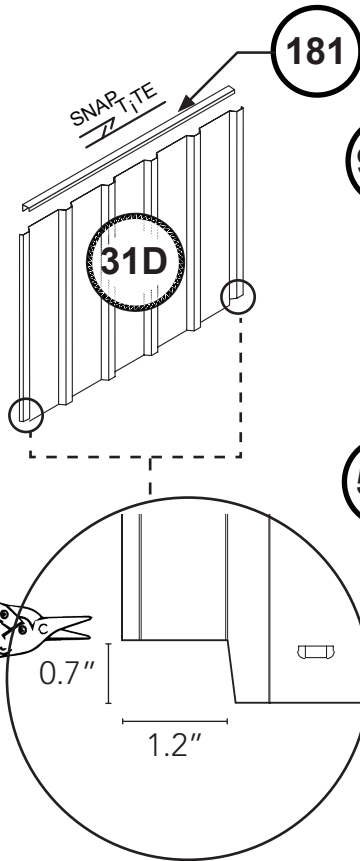

Notch out both bottom corners as shown using tinsnips.

3.

FAST001 x8

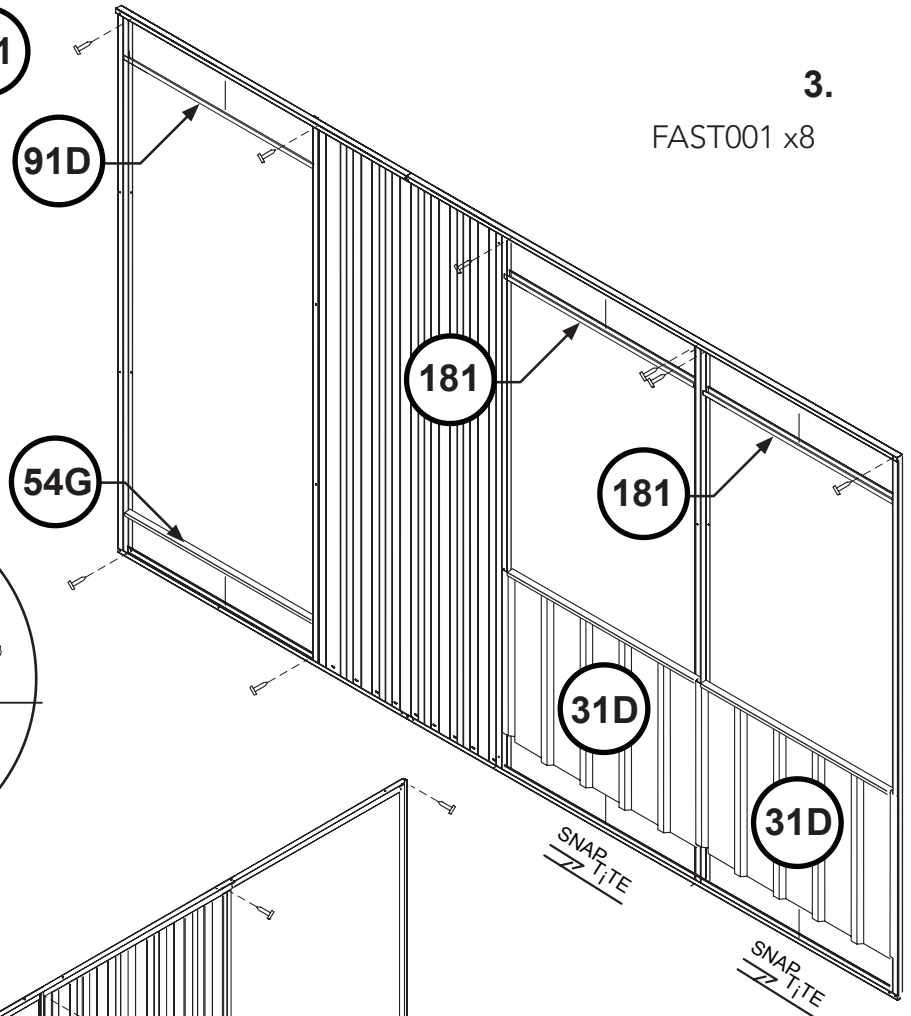

4.

FAST001 x14
FAST009 x 8

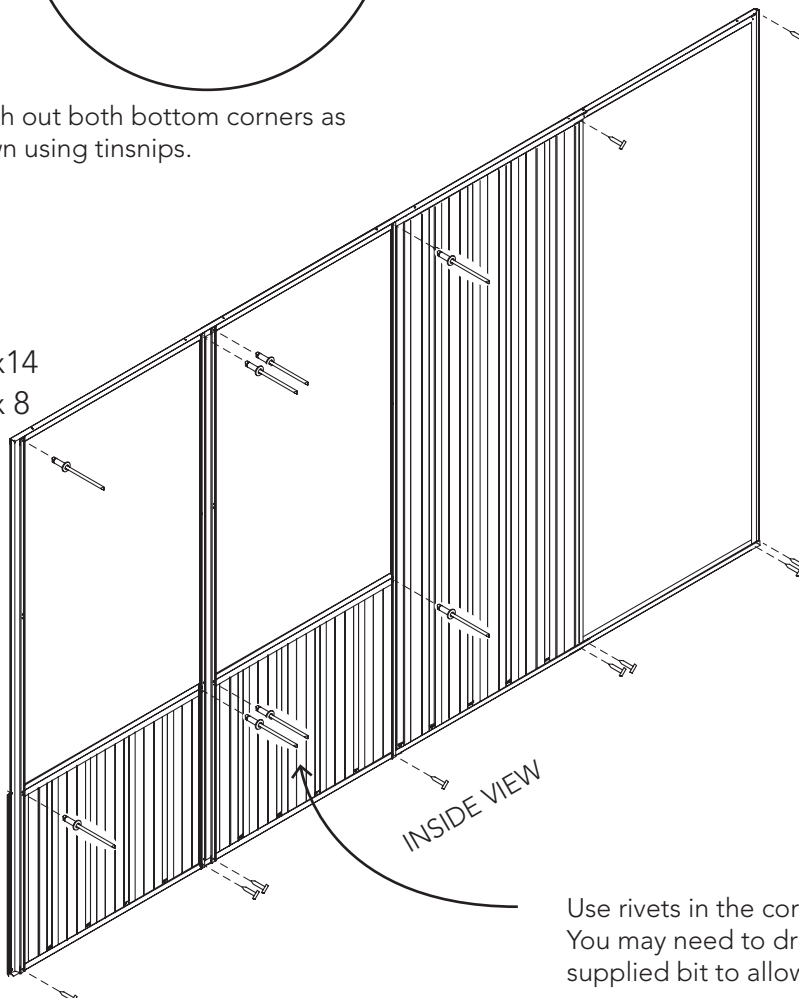

Use rivets in the corners of the window openings. You may need to drill through aligned holes with supplied bit to allow a better fit for the rivet head.

DOOR PANEL ASSEMBLY

1x required

FAST001 x12

Narrow pan of sheet to this side

SNAP TITE

58M

Position 12A midway along the door.

58A

12A

37A

58B

58M

SNAP TITE

Side channels of door are to be orientated opposite to top and bottom channels.

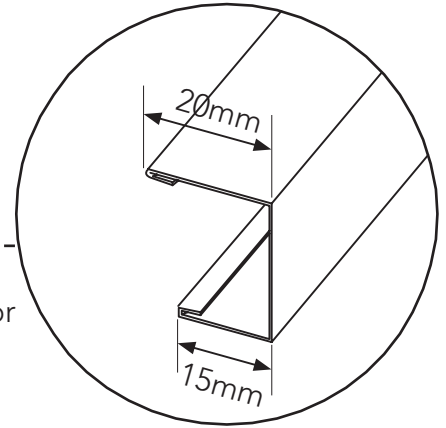

20mm flange

15mm flange

FAST001 x4

FAST006

Side channels are positioned behind top and bottom channel.

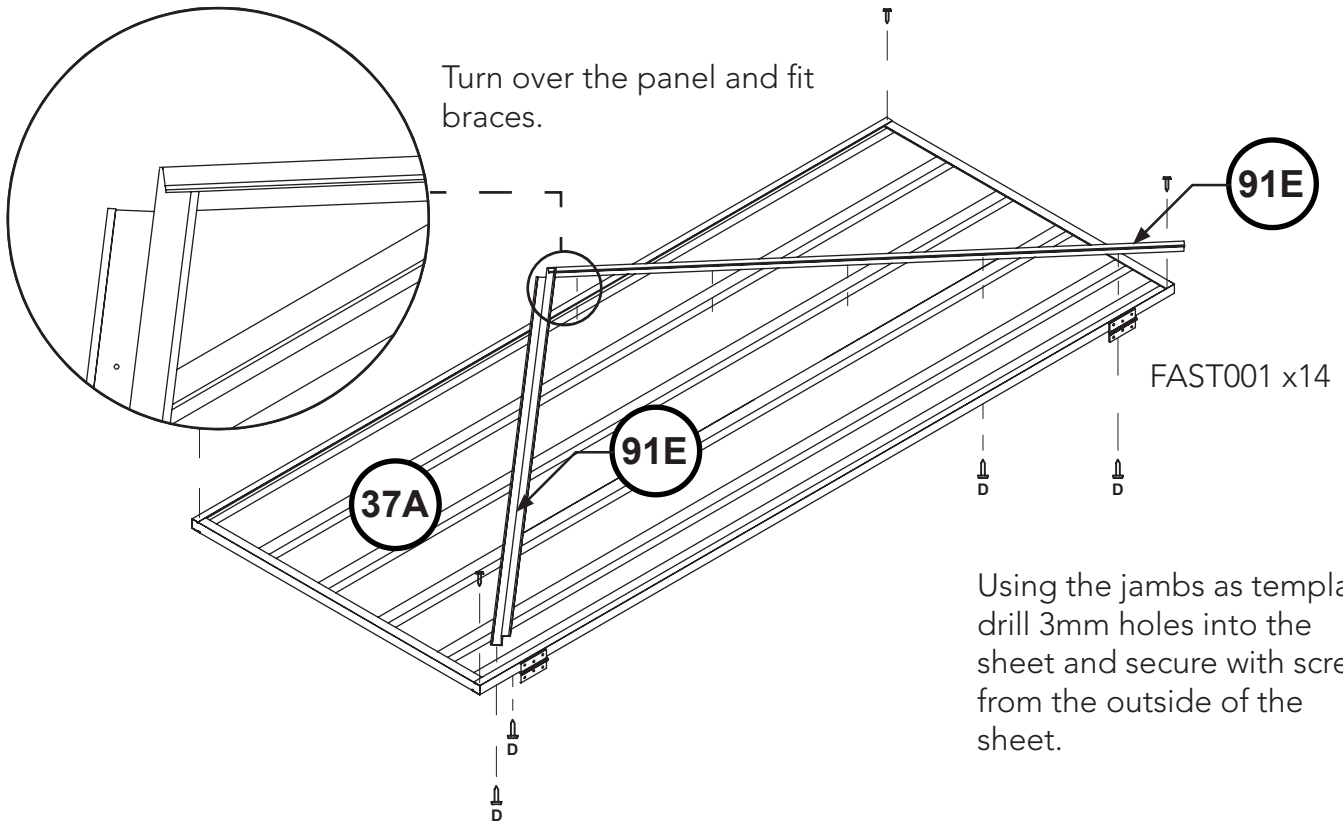

Using the jambs as templates drill 3mm holes into the sheet and secure with screws from the outside of the sheet.

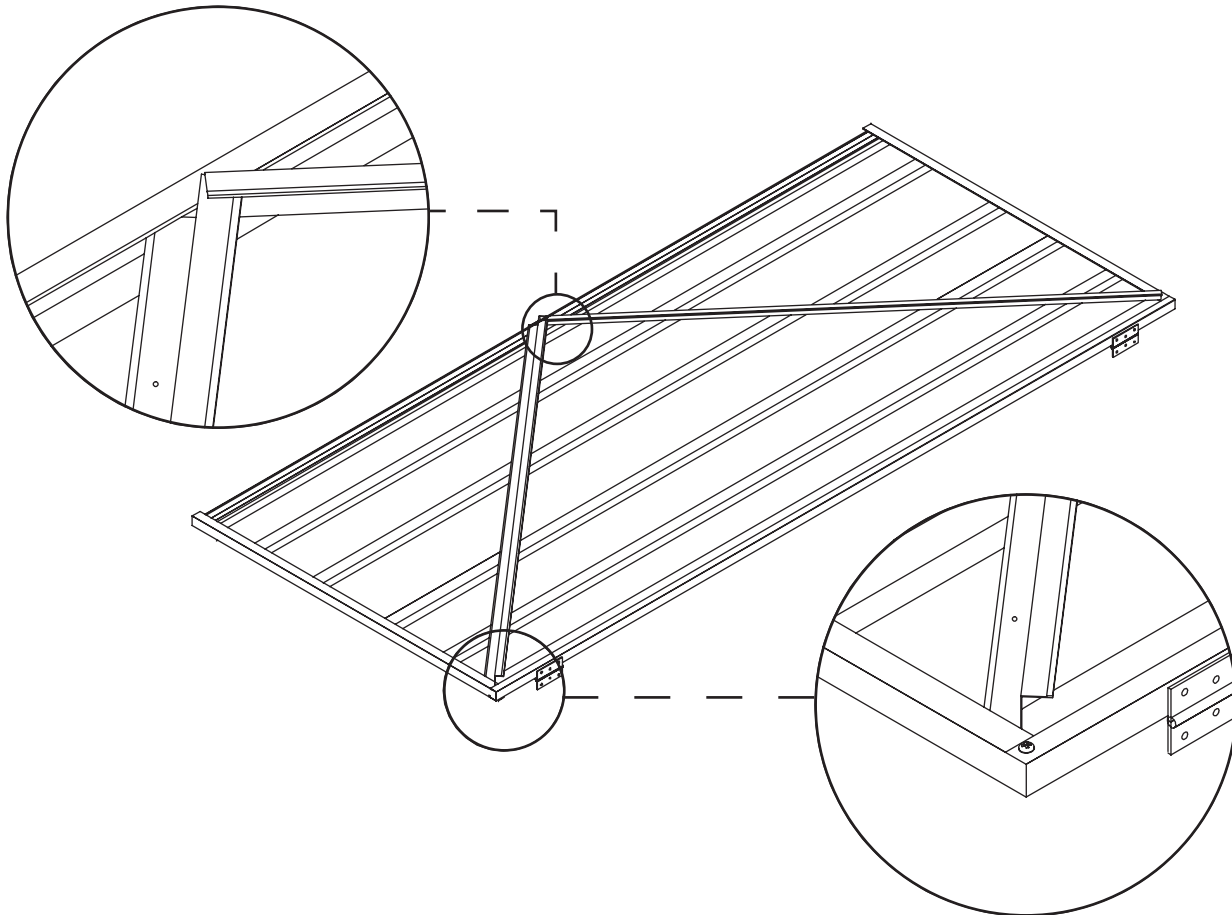

DOOR PANEL ASSEMBLY

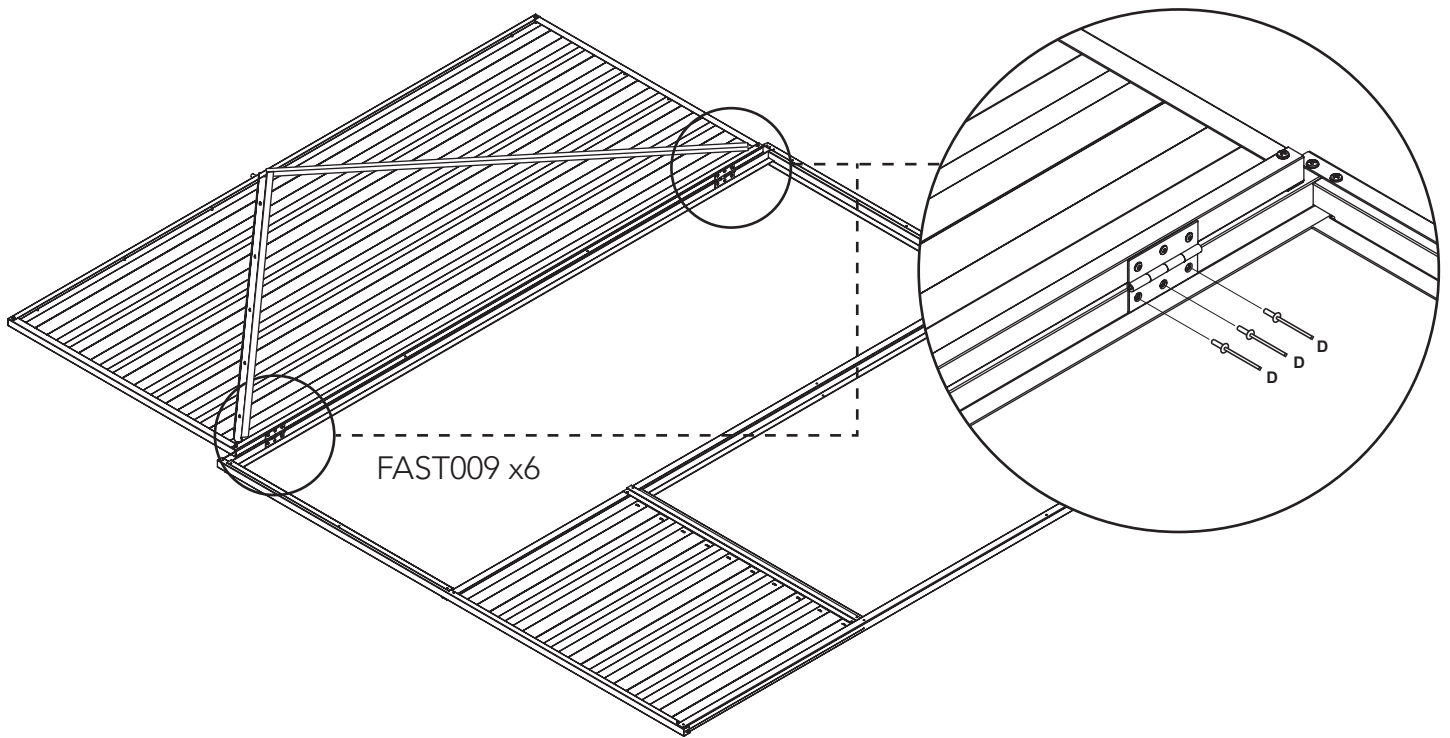

Lay the LEFT SIDE PANEL face up and lay the DOOR PANEL down in the open position on top as shown.

Using three rivets per hinge, FAST009, secure the door to the frame.

NOTE: Run the 1/8" drill bit through the punched holes in the jamb before riveting the hinge on.

FRONT PANEL

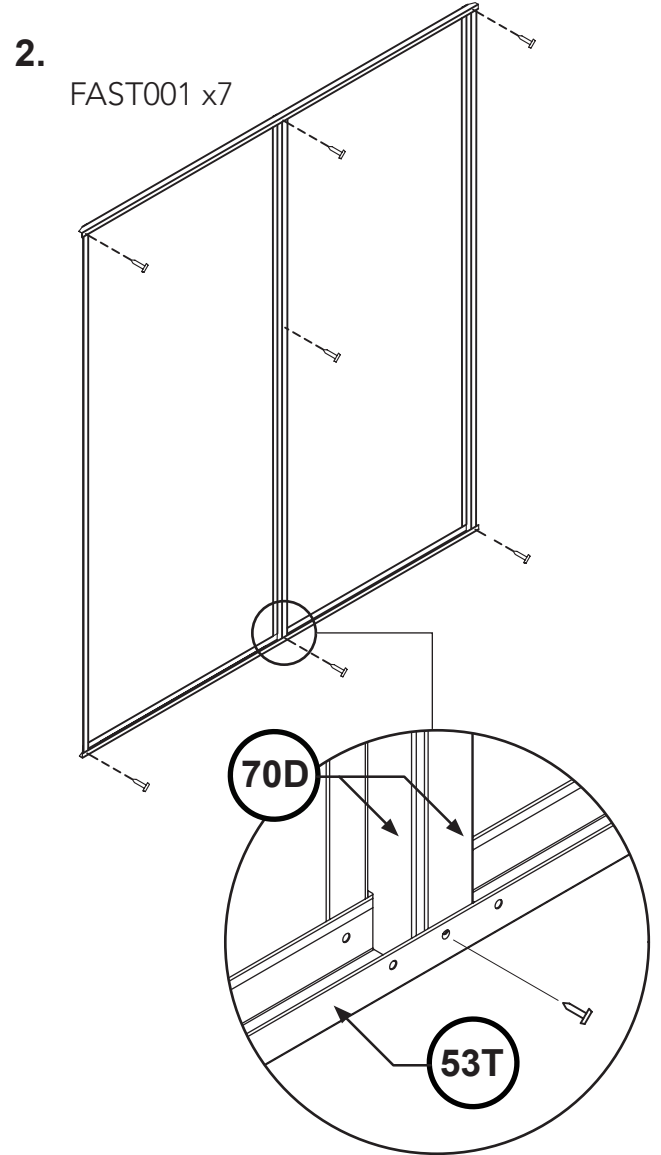
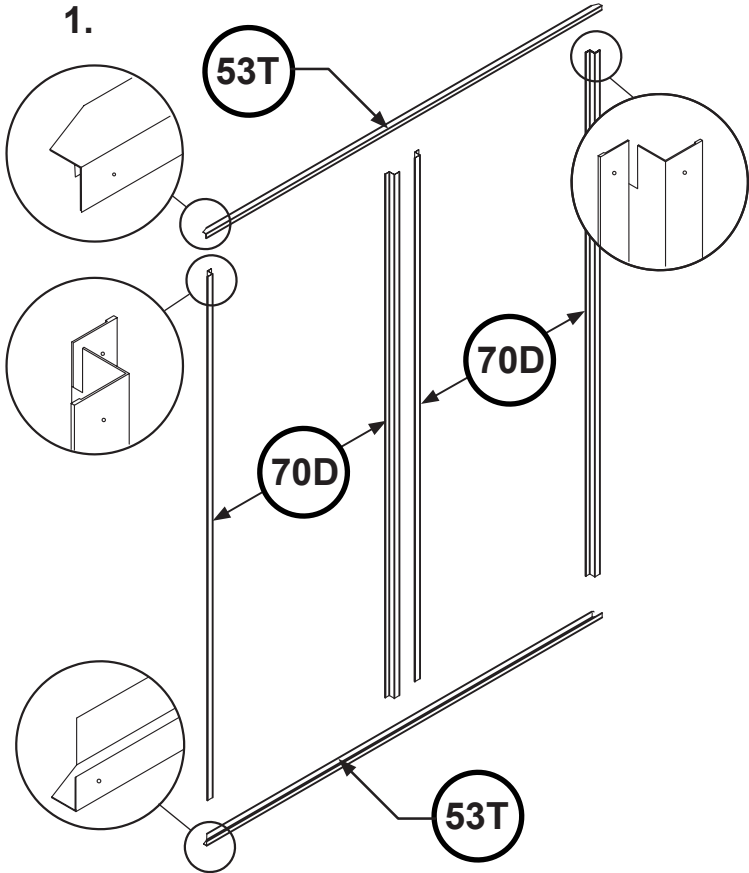

3.
Prepare two short sheets

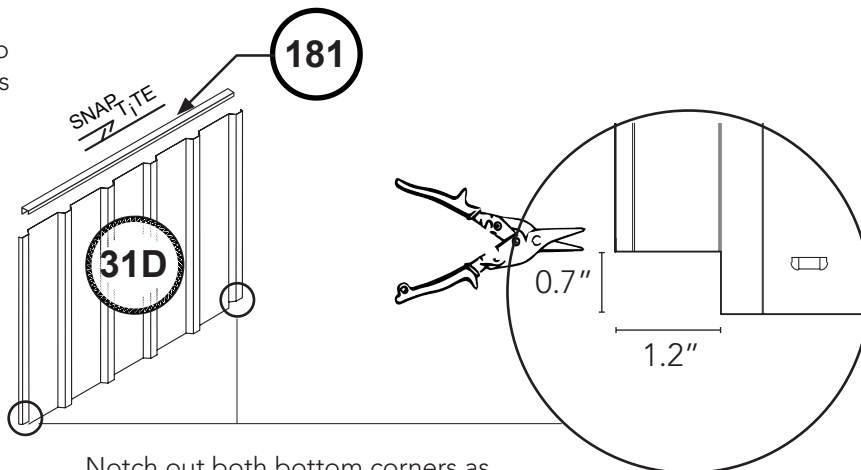

Notch out both bottom corners as shown using tinsnips.

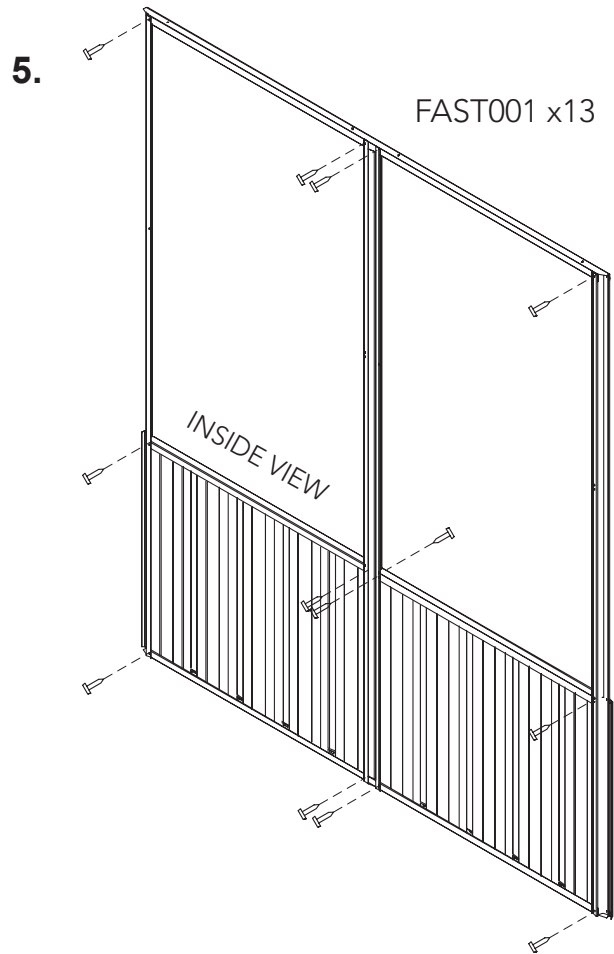
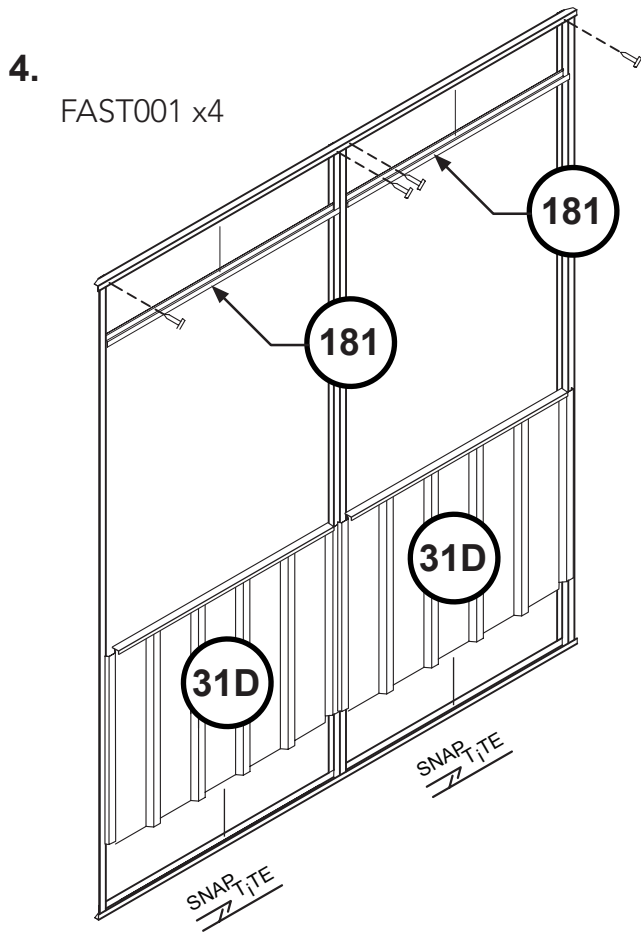

FITTING MESH PANELS

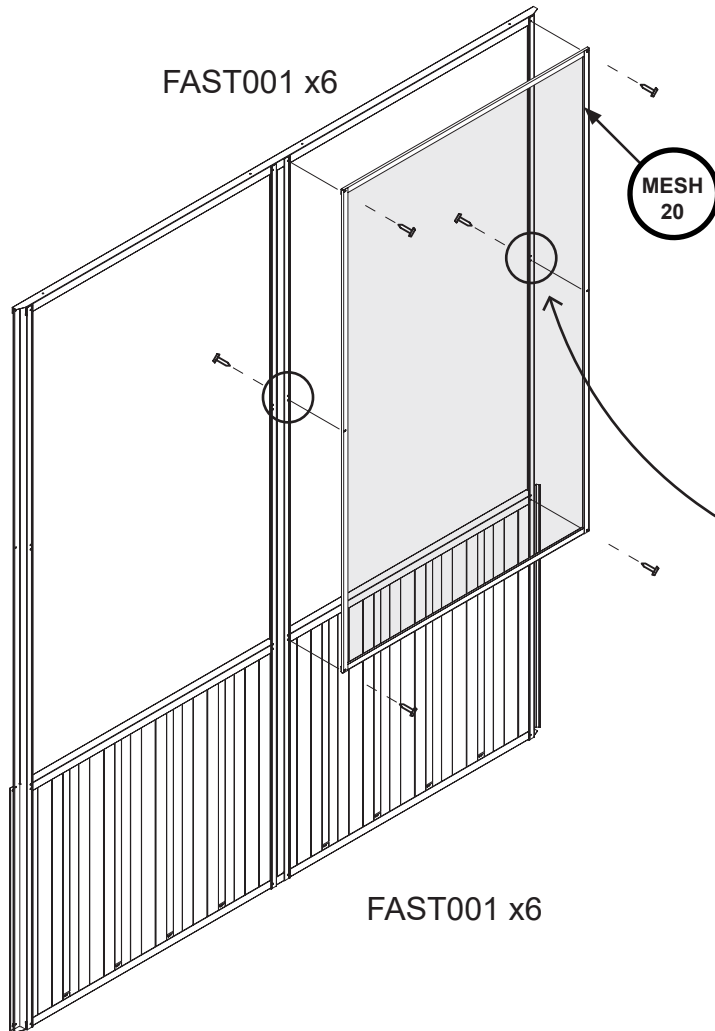

The mesh panels are fixed to the **inside** of the wall panels.

There's six holes in the border of the mesh panel, these are fixed with FAST001 screws.

1. Start by aligning the middle pair of mesh holes with these lower 70D holes and fasten with screws from outside.

2. The four corner holes are to be drilled out into the top and bottom channels using the with the supplied 1/8" drill bit and fastened from inside the panel using four FAST001 screws.

3. Repeat these steps for every mesh position.

NOTE: If the mesh panel is not sitting flush enough for your liking you may drill more 1/8" holes and fasten with additional FAST001.

WARNING: It is recommended that new galvanised mesh should be weathered for two (2) months or scrubbed with a mild acidic solution, such as vinegar, then rinsed with water before being used in bird housing applications.

PANEL CONSTRUCTION

NOTE: Take care to ensure that all wall panels are not upside down. The top channels of each panel are pre-punched for attaching roof sheeting. The base channels are not pre-punched.

Mesh panels are not shown for illustrative purposes.

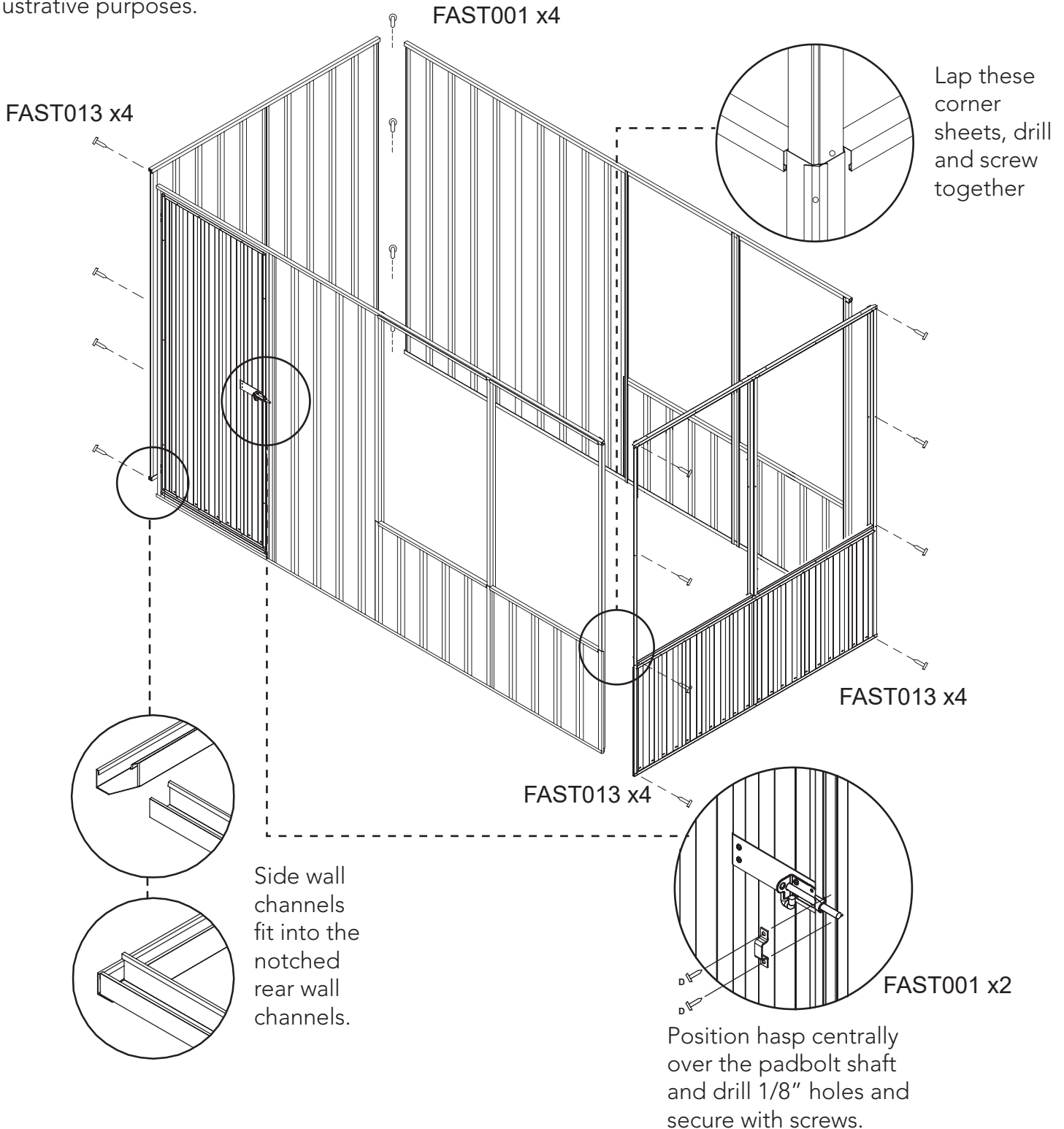

FINAL CONSTRUCTION

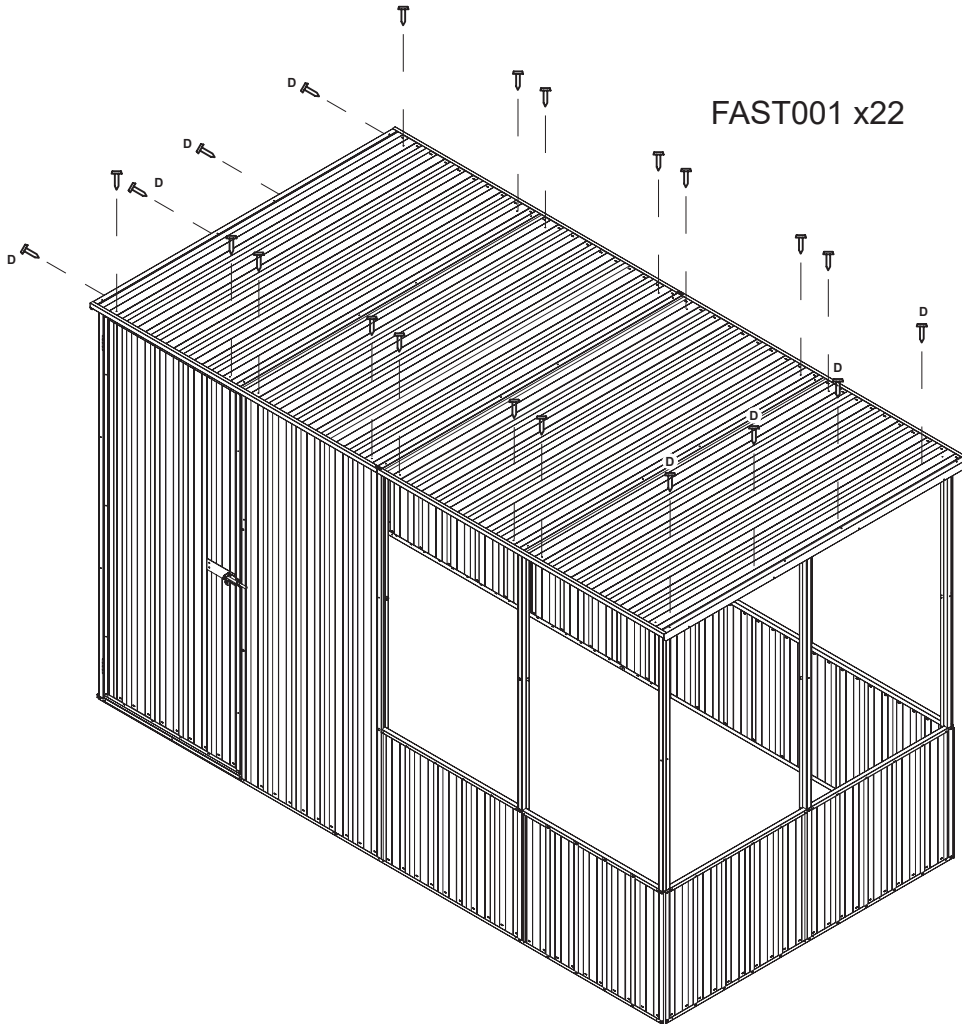

Position the roof so that the back wall has the lip trim against it with the roof overhang to the front.

Line up the holes in the roof sheet with side wall top channels. Secure with screws.

Line up the holes in the roof lips with holes in the top channel of the side panels.

Secure with screws.

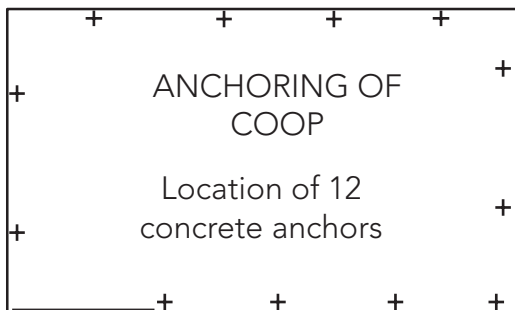

- EACH ANCHOR CONSISTS OF ONE NUT & BOLT, A DYNABOLT AND STEEL ANGLE.
- DRILL A HOLE IN THE WALL SHEET TO SUIT BOLT.
- DRILL A HOLE IN THE SLAB TO SUIT DYNABOLT.

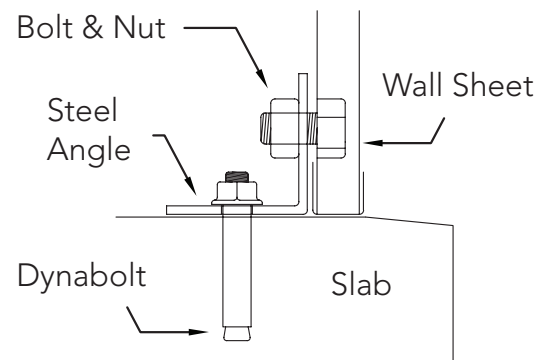



Absco Sheds Storage Guidelines

- Absco Sheds are designed to be weatherproof for normal weather conditions. In the event of extreme weather conditions such as heavy rain, combined with high wind gusts, the ridge capping, sheeting joints, screw fixings etc., may exhibit minor deformations which may allow some water entry. These areas should be checked regularly to ensure that maximum strength and protection is maintained.
- Other weather conditions such as extreme heat and extreme cold, moist or dry air can influence the effects of concrete floor moisture and/or condensation on the underside of the roof sheets.
- Absco Sheds and storage units are primarily used for storage of garden equipment such as lawnmowers, wheelbarrows, garden tools etc. Storage items that might be adversely affected by any of the above conditions may require additional protection such as being sealed or covered by plastic sheets and/or stacked above the concrete floor on timber slats.
- Waterproof sealants may be used to offer further protection where required around joins and screw fixings, as can rubber door seals and other products which are available from most hardware outlets.
- Placement of waterproof sealants (silicone) between the base of the shed and concrete slab is not recommended, as this process can have a reverse effect, preventing excess water from escaping, resulting with water accumulating and being trapped inside the shed.
- Absco accepts no responsibility for water entry, floor moisture, condensation or the condition of the Contents inside your Absco steel building arising from any of the pre-mentioned weather conditions.



EXPORT PRODUCT WARRANTY AGAINST DEFECTS

Congratulations on your purchase of an ABSCO SHED

ABSCO SHEDS, including garden sheds, garden beds, aviaries, storage units, garages, awnings and carports are made using high quality Australian made steel.

We are pleased to advise we warrant that the steel coating will not rust, crack, flake peel or blister for 12 years from date of purchase.

This warranty does not apply to surface deterioration of panels caused by "Swarf" (Tiny particles of steel debris left from cutting, grinding or drilling operations) that has not been removed after building construction, or as a result of contact with damp soil, chemicals, fertilisers or other corrosive substances.

This warranty covers any Absco product used for normal domestic use and installed in accordance with the installation instructions.

This warranty does NOT cover Damage caused by storms, wind, rain, snow or poor foundations.

This warranty does NOT cover ABSCO products installed in severe coastal, industrial or other highly corrosive environments. The warranty does not cover fasteners (screws, nuts, bolts, rivets, hasps or sliding padbolts).

The warranty is limited to replacement and delivery of components and does not include any labour or installation costs. The benefits given by the warranty are in addition to your other rights and remedies under a law in relation to the goods or services to which the warranty relates.

In the unlikely event a warranty claim is made, it must be supported by photographic evidence and details of the defect, including component part numbers, together with proof of purchase documentation (or on-line registration of purchase) and forwarded to the address below. Upon receipt of the warranty claim, the Customer Service Manager will contact you within three business days to advise you of the assessment outcome of the claim, which may include your expenses incurred in making the claim.

THE CUSTOMER SERVICE MANAGER, ABSCO SHEDS, PO BOX 119 ACACIA RIDGE QLD AUSTRALIA 4110

PHONE: +1 (866) 788 3046

EMAIL: warranty@absco.com.au

Issued 16 July 2019