

ASSEMBLY APP AVAILABLE ON  + 

We highly recommend downloading the Absco Sheds Assembly App to assist with your build.

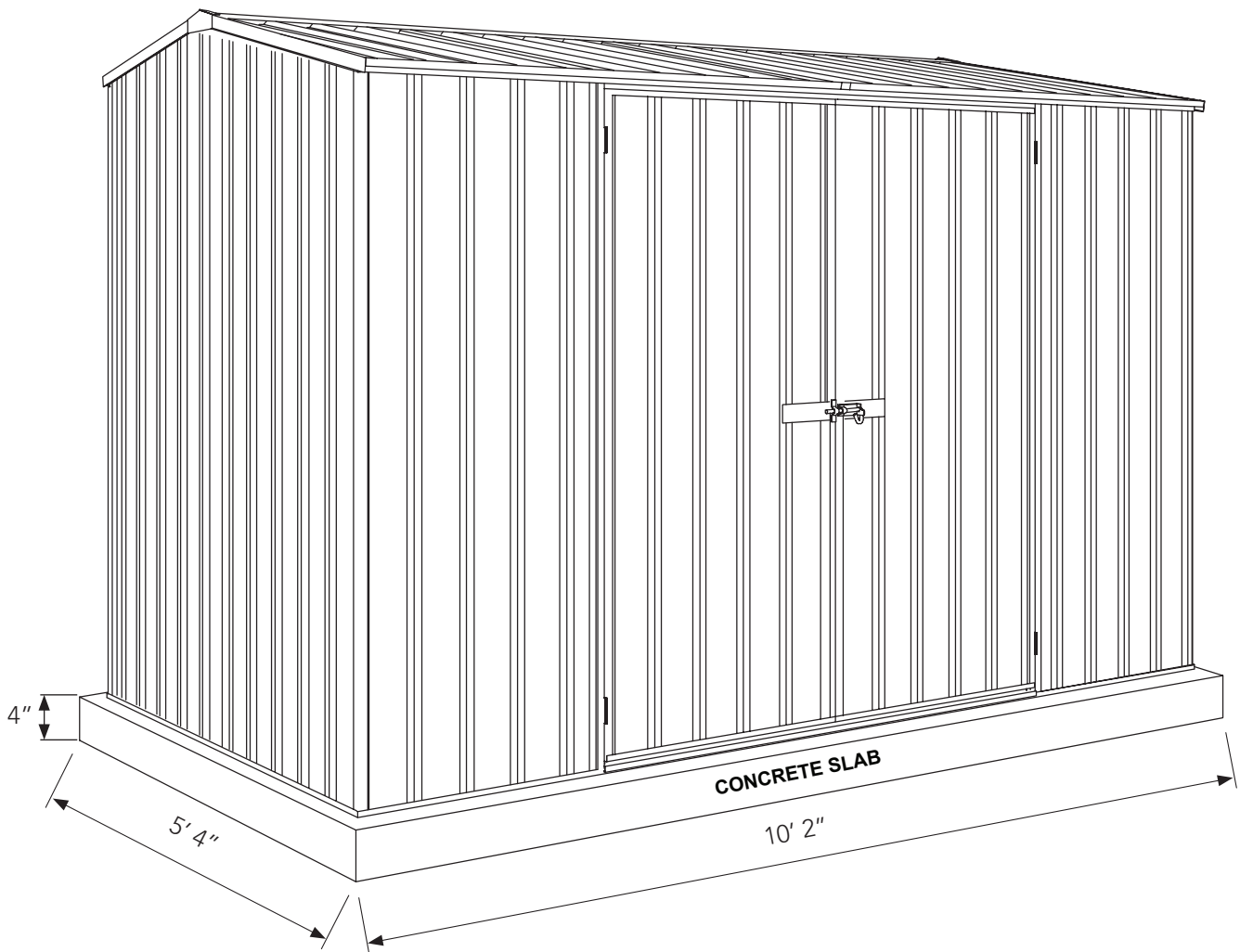

STEP BY STEP ASSEMBLY VIDEOS • PARTS CHECKLISTS • FAQ • 7 DAY CUSTOMER SERVICE • WARRANTY INFORMATION



When laying a concrete slab for your shed, it is best practise to have a rebated edge to prevent water ingress.

Rebated section is 1" high and inset 3" on all sides from the overall slab base dimensions

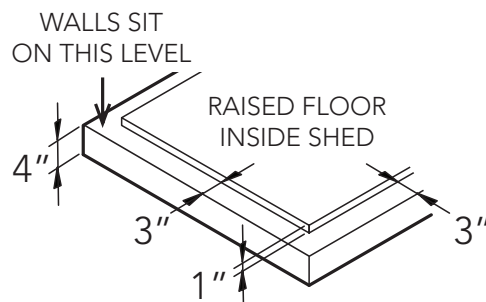

Overall slab base dimensions for this model are as shown above.

Illustration not to scale.

GENERAL INSTRUCTIONS

- Before commencing any assembly, read through these instructions in detail to gain a thorough understanding of assembly methods and associated details.
- Unpack the carton and carefully identify and check off all the parts against the parts described and illustrated on "COMPONENTS PACKING LIST" pages.

SITE PREPARATION

- The site for the shed must be level. An uneven surface may result in misalignment of parts.
- The shed shall be erected on top of a reinforced concrete slab and anchored down appropriately illustrated on "FINAL CONSTRUCTION" page.

SAFETY NOTES

- Some parts may have sharp edges. It is advisable to wear gloves when handling these items and safety glasses if drilling holes. Sensible shoes are highly recommended.
- Do not erect your shed in windy conditions.
- Ensure that the shed is securely anchored to a solid foundation immediately after construction is completed.
- It is highly recommended to erect the shed with two or more people.
- Do not sit, stand or walk on the roof of your shed.

RECOMMENDED



Personal protective equipment for tools



Hand Protection



Enclosed Shoes



Raised work surface. EG Sawhorses and timbers



Heavy and/or bulky. Multi-person lift or mechanical aid.

TOOLS REQUIRED

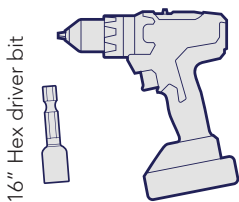

5/16" Hex driver bit
Cordless drill

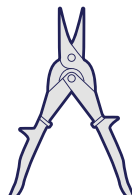

Tin snips

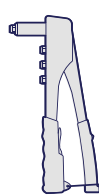

Pop riveter



Ladder

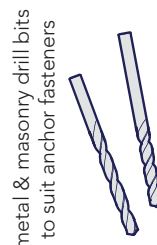

metal & masonry drill bits to suit anchor fasteners

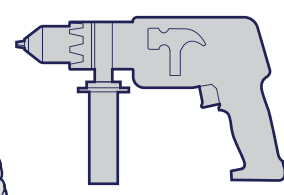

Hammer drill



Shifter

NUMBER OF PEOPLE REQUIRED



2 - 3 people

NUMBER OF HOURS REQUIRED



Approx. 6 hours













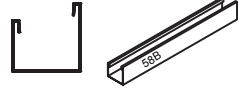

ASSEMBLY DIFFICULTY

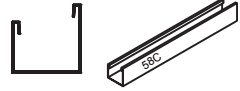
Basic





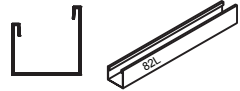

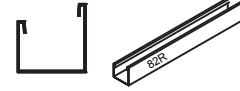





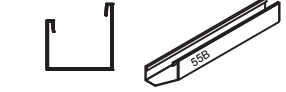

Complex

COMPONENTS PACKING LIST - CHECK OFF ALL COMPONENTS

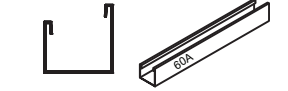
QTY	COMPONENT DESCRIPTION	PART No.	CHECK	QTY	COMPONENT DESCRIPTION	PART No.	CHECK
2	 STEEL SHEET 5' 10 9/32" Long 2' 6 7/16" Wide	30A		2	 PEAK BRACE	15A	
2	 STEEL SHEET 5' 10 9/32" Long 2' 6 7/16" Wide	31A		2	 CHANNEL WITH HINGES L = 5' 7 29/32"	58A	
2	 STEEL SHEET 5' 10 9/32" Long 2' 3 63/64" Wide	34A		1	 CHANNEL L = 5' 7 29/32"	58B	
2	 STEEL SHEET 6' 3 25/64" Long 2' 6 7/16" Wide	36L		4	 CHANNEL L = 2' 6 7/16"	58C	
2	 STEEL SHEET 6' 3 25/64" Long 2' 6 7/16" Wide	36R		1	 CHANNEL L = 5' 1 47/64"	79A	
8	 STEEL SHEET 2' 7 5/16" Long 2' 6 7/16" Wide	52A		2	 CHANNEL L = 4' 11 9/16"	81E	
1	 STEEL SHEET 5' 7 29/32" Long 2' 6 7/16" Wide	B		2	 CHANNEL L = 2' 6 3/16"	82L	
1	 STEEL SHEET 5' 7 29/32" Long 2' 6 7/16" Wide	A		2	 CHANNEL L = 2' 6 3/16"	82R	



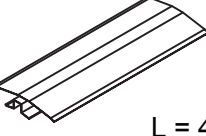
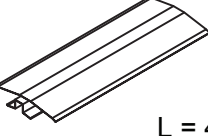



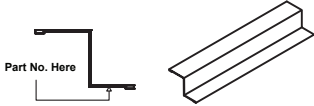
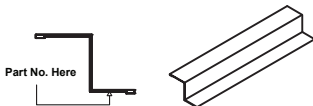
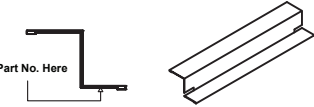
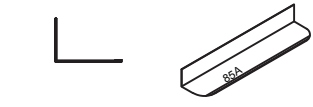
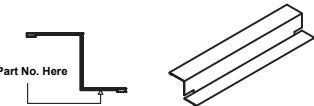

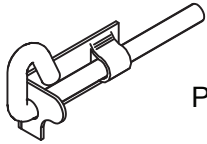
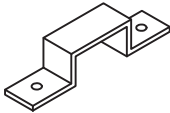

COMPONENTS PACKING LIST - CHECK OFF ALL COMPONENTS

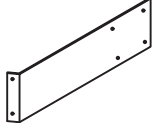
QTY	COMPONENT DESCRIPTION	PART No.	CHECK	QTY	COMPONENT DESCRIPTION	PART No.	CHECK
8	 CHANNEL JOINER L = 7 7/8"	CSJ		1	 RIDGE BEAM JOINER L = 1' 5 23/32"	ZARSP	
↓ THESE COMPONENTS ↓ ARE TO BE JOINED ↓ TO THESE COMPONENTS ↓							
1	 CHANNEL L = 4' 10 59/64"	55AL		1	 CHANNEL L = 4' 10 59/64"	55AR	
1	 CHANNEL L = 4' 10 59/64"	55CL		1	 CHANNEL L = 4' 10 59/64"	55CR	
1	 CHANNEL L = 4' 10 59/64"	55BL		1	 CHANNEL L = 4' 10 59/64"	55BR	
2	 CHANNEL L = 4' 10 59/64"	60AL		2	 CHANNEL L = 4' 10 59/64"	60AR	
2	 CHANNEL L = 3' 8 11/32"	81AL		2	 CHANNEL L = 3' 8 11/32"	81AR	
1	 CHANNEL L = 4' 10 59/64"	81BL		1	 CHANNEL L = 4' 10 59/64"	81BR	
1	 RIDGE BEAM L = 4' 11 7/8"	97AL		1	 RIDGE BEAM L = 4' 11 7/8"	97AR	

COMPONENTS PACKING LIST - (CONT.) CHECK OFF ALL COMPONENTS

QTY	COMPONENT DESCRIPTION	PART No.	CHECK	QTY	COMPONENT DESCRIPTION	PART No.	CHECK
2	 Part No. Here JAMB L= 5' 10 1/4"	89A		4	 Part No. Here JAMB L= 3' 8 1/8"	91A	
1	 Part No. Here JAMB L= 5' 7 15/16"	89C		4	 LIP TRIM L= 2' 7 5/16"	85A	
1	 Part No. Here JAMB L= 5' 1 3/4"	90A					

CONTENTS OF FITTINGS PACKET

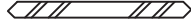
3	 DOOR PADBOLT	22A		2	 DOOR PADBOLT HASP		
2	 ABSCO CAP GABLE L: 6 11/16"	14A		2	 DOOR STRAP L: 6 1/2"	12A	
220	 SELF TAPPING SCREWS			12	 POP RIVETS SECURE HINGES TO DOOR		
8	 5/32" NUT & BOLT SET SECURE TWO PADBOLTS TO DOOR SHEET			1	 RIVET GUN		
12	 11/64" CSK SCREW & NUT SECURE HINGES TO DOOR (ALTERNATE METHOD)			1	 HEX TEK SCREW DRIVER BIT		
8	 SELF DRILLING HEX HEAD TEK SCREWS (NO HOLE REQUIRED)			1	 1/8" DRILL BIT		

INSTRUCTIONS FOR JOINING SPLICED CHANNELS

NOTE: THE TEXT MARKED ON ALL PARTS MUST BE SHOWN ON THE SAME SIDE AS EACH OTHER.

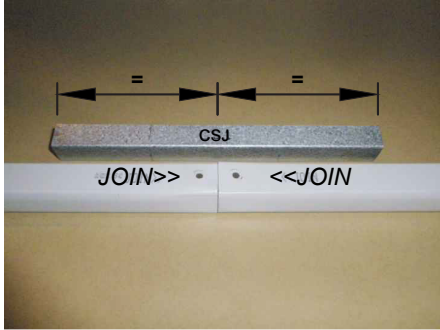

STEP 1.

Position the channels and the CSJ joiner channel so the center of the CSJ is in line with the end of each channel to be joined together.

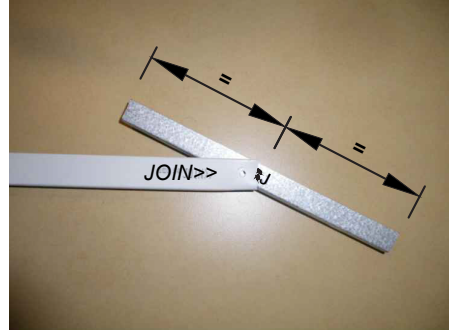

STEP 2.

Join the first channel to the CSJ by inserting the center of the CSJ (on an angle) to the end of the channel where the JOIN>> text is marked. Push down one side of the CSJ until you hear a 'click'.

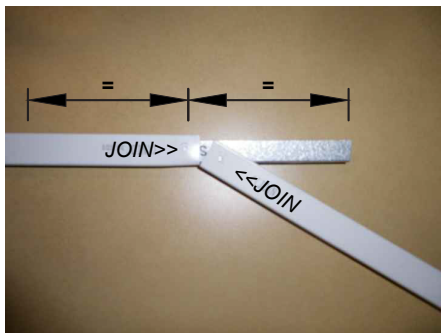

STEP 3.

Join the second channel to the CSJ by positioning the <<JOIN end of the channel at the center of the CSJ (on an angle). Push the CSJ into the channel until you here a 'click'.

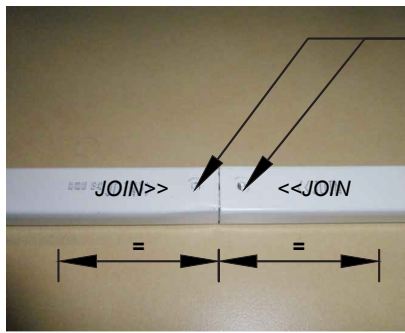

FINISHED CHANNEL

The joined channels should now look like the picture above with the CSJ positioned equally inside of the joined channels.

DRILL 4mm (0.16") x 3mm (0.12") (2 PER A SIDE) HOLES TO SECURE SECTIONS TOGETHER. (THESE SCREWS MAY HAVE TO BE TEMPORARILY REMOVED AND REPLACED DURING LATER ASSEMBLY)

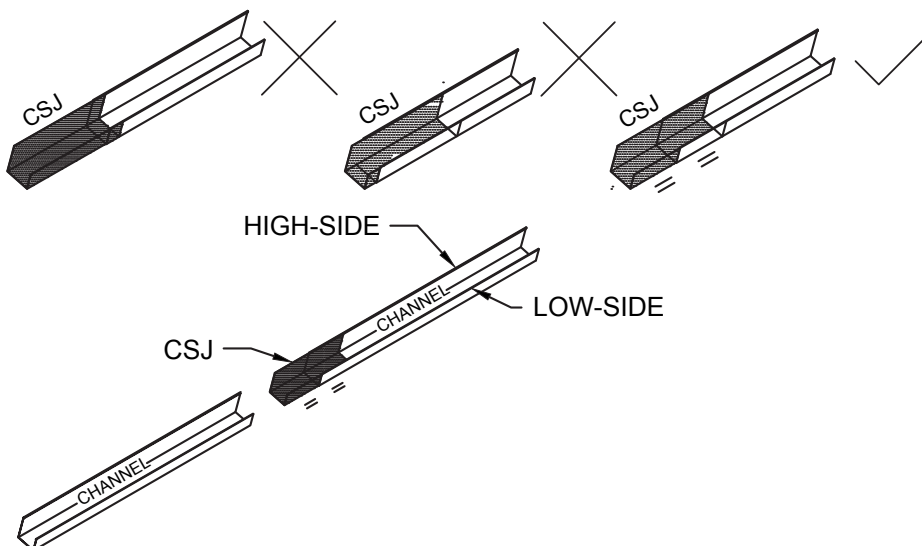
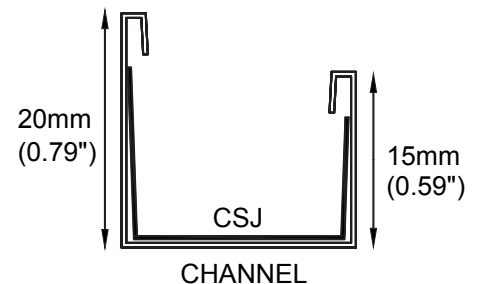
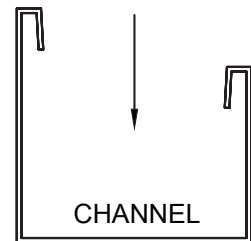
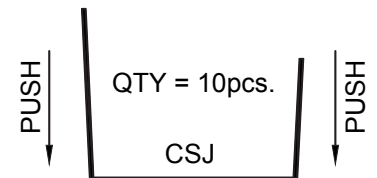

STEP 1. PRE-ASSEMBLY OF SPLICED CHANNELS

NOTE: JOIN TOGETHER 16 X CHANNEL SECTIONS USING 8 X CHANNEL JOINERS (PART CSJ)

IMPORTANT:
SOME CHANNELS HAVE HOLES IN THEM - YOU WILL NEED TO RE-DRILL HOLES ON ANY CHANNEL WHERE THE CSJ JOINING CHANNEL COVERS HOLES ON THE CHANNELS YOU ARE CONNECTING

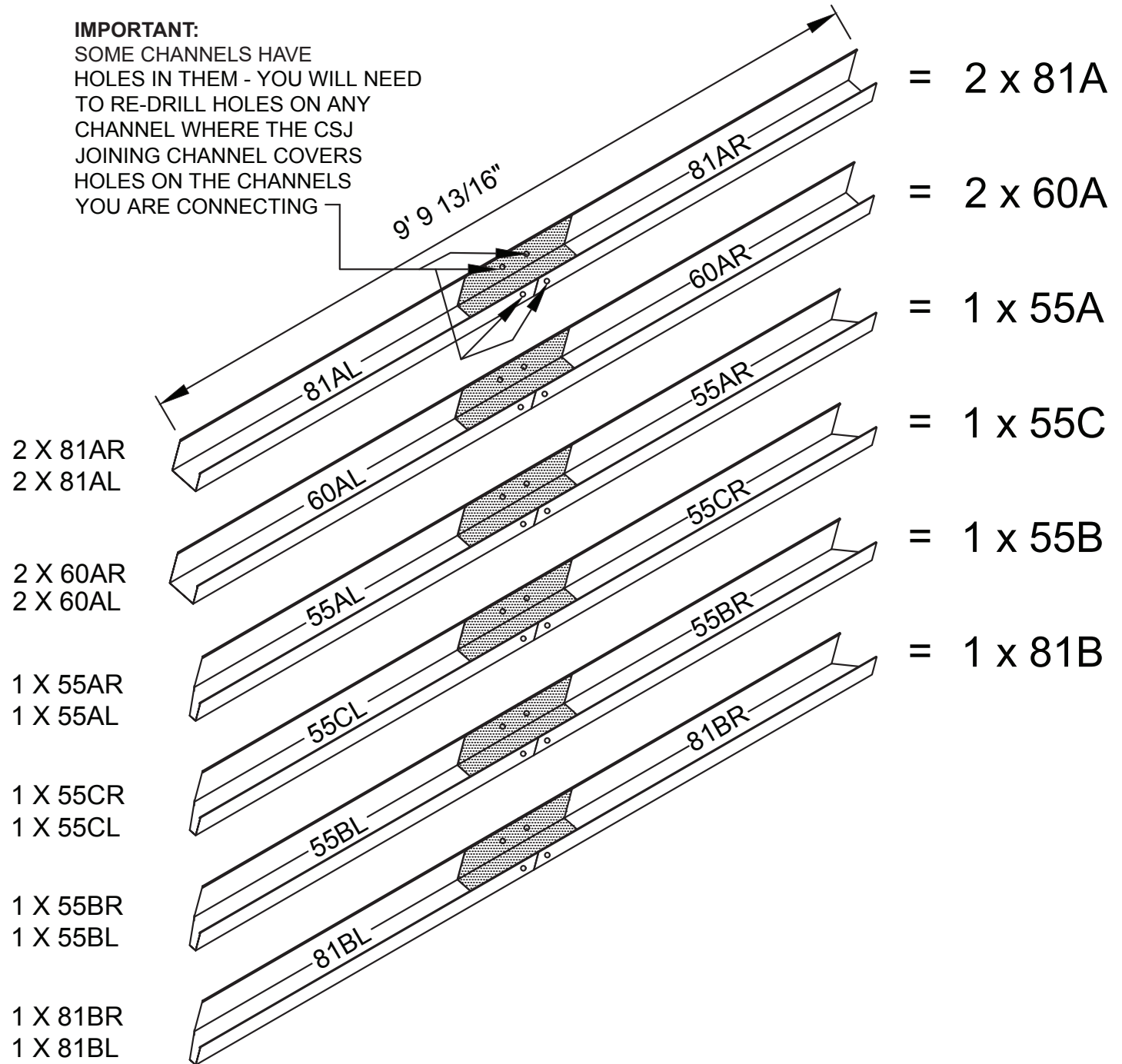

STEP 2. PRE-ASSEMBLY OF SPLICED RIDGE BEAM

QTY. = 1  TEK SCREW DRIVER BIT

QTY. = 8  SELF DRILLING TEK SCREW

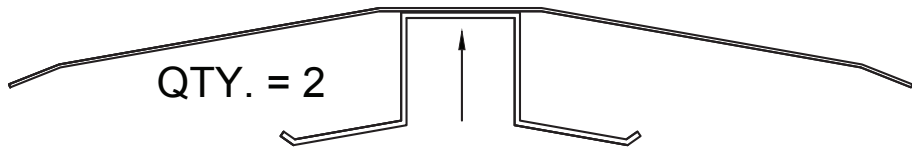
QTY. = 2  RIDGE BEAM 4' 11 7/8"
PARTS 97AL & 97AR

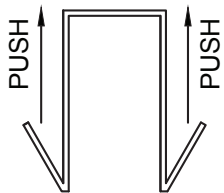
QTY. = 1  PART ZARSP - 1' 5 11/16" LONG

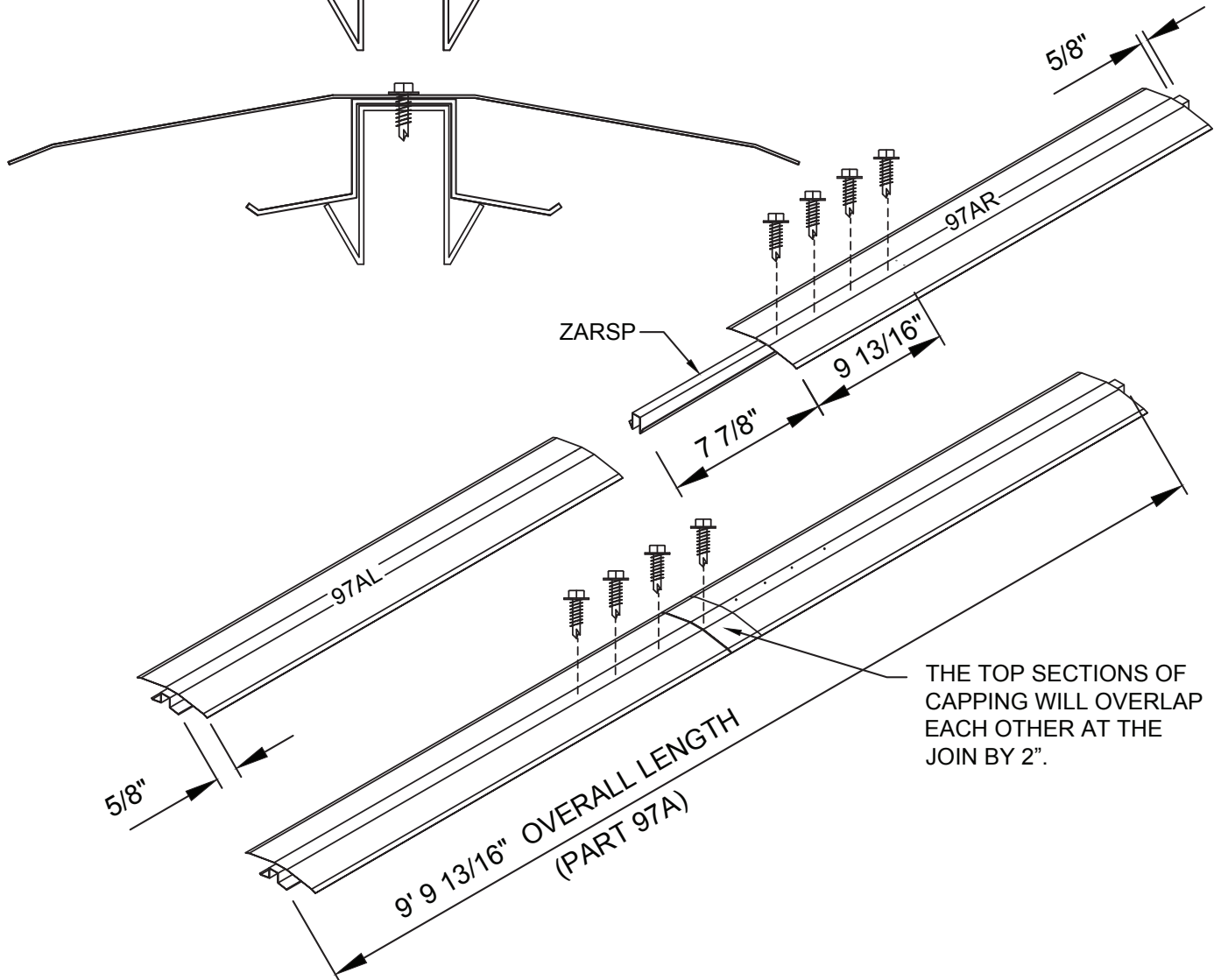

INSTRUCTIONS FOR JOINING SPLICED RIDGE BEAM

STAGE 1: PUSH RIDGE BEAMS TOGETHER, MAKE SURE THERE IS A 2" OVERLAP OF THE RIDGE CAP

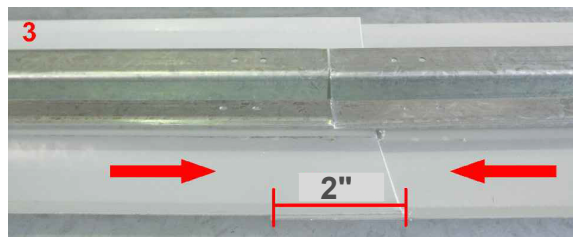
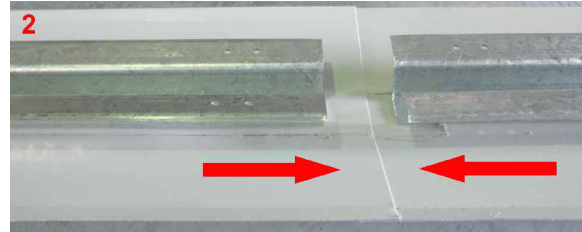
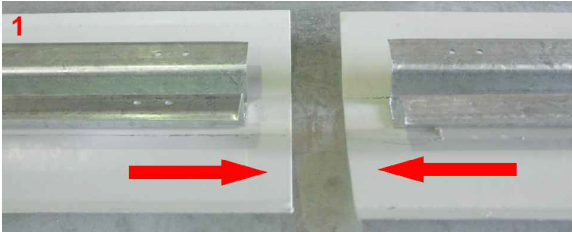

INSTRUCTIONAL VIDEOS



STAGE 2: INSERT RIDGE CAP JOINER INTO CONNECTED RIDGE CAPS. MAKE SURE JOINER HAS 8 55/64" IN EACH RIDGE CAP.

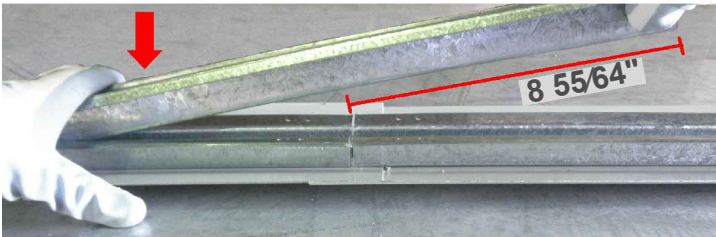

STAGE 3: TURN RIDGE CAP OVER AND MEASURE 9 27/32" FROM THE END OF EACH RIDGE CAP. PLACE TEK SCREWS IN 2" INCREMENTS FROM SAID END. REPEAT THIS PROCESS FOR THE OPPOSING HALF OF RIDGE BEAM





VIEW OF ROOF COMPONENTS

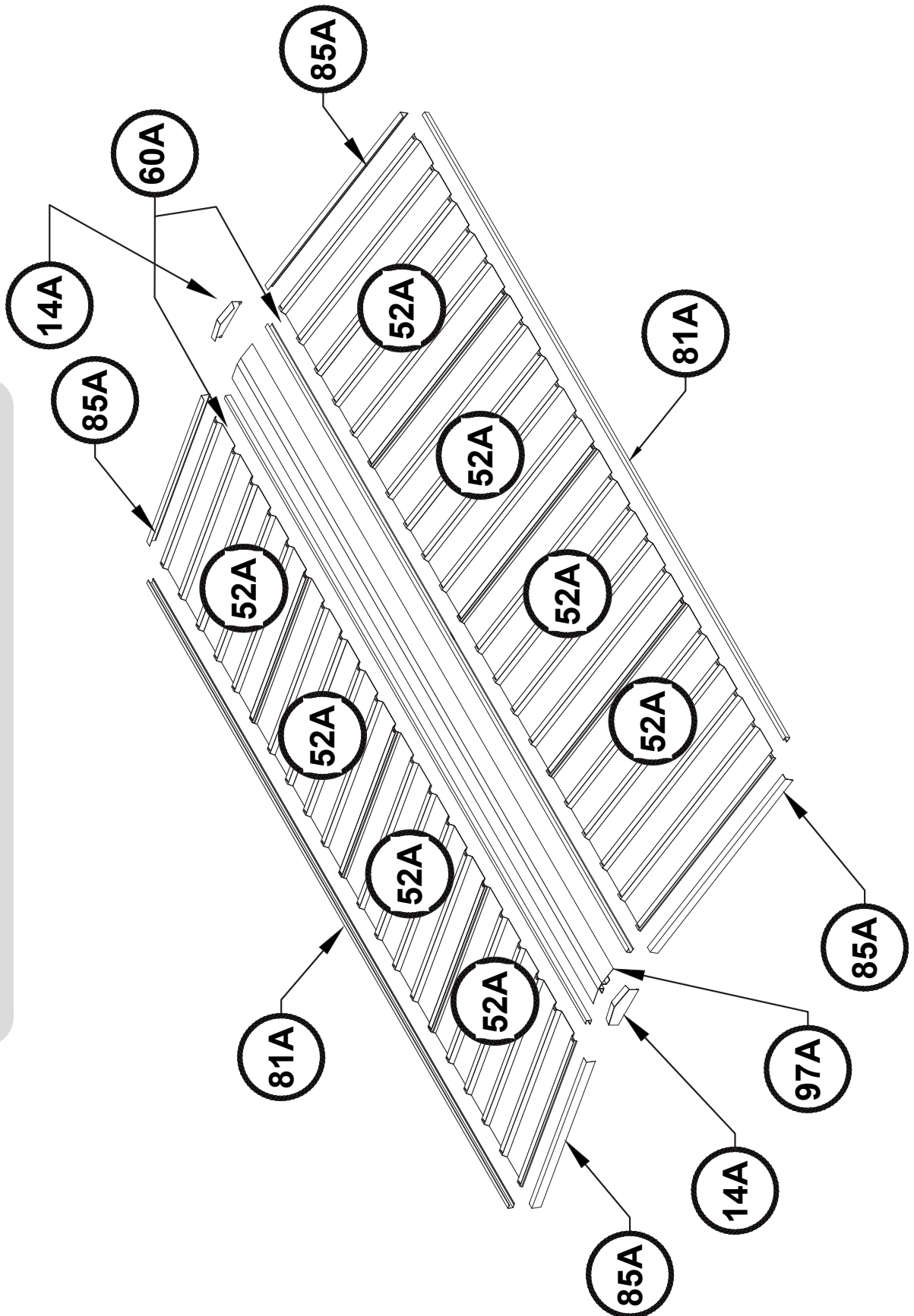

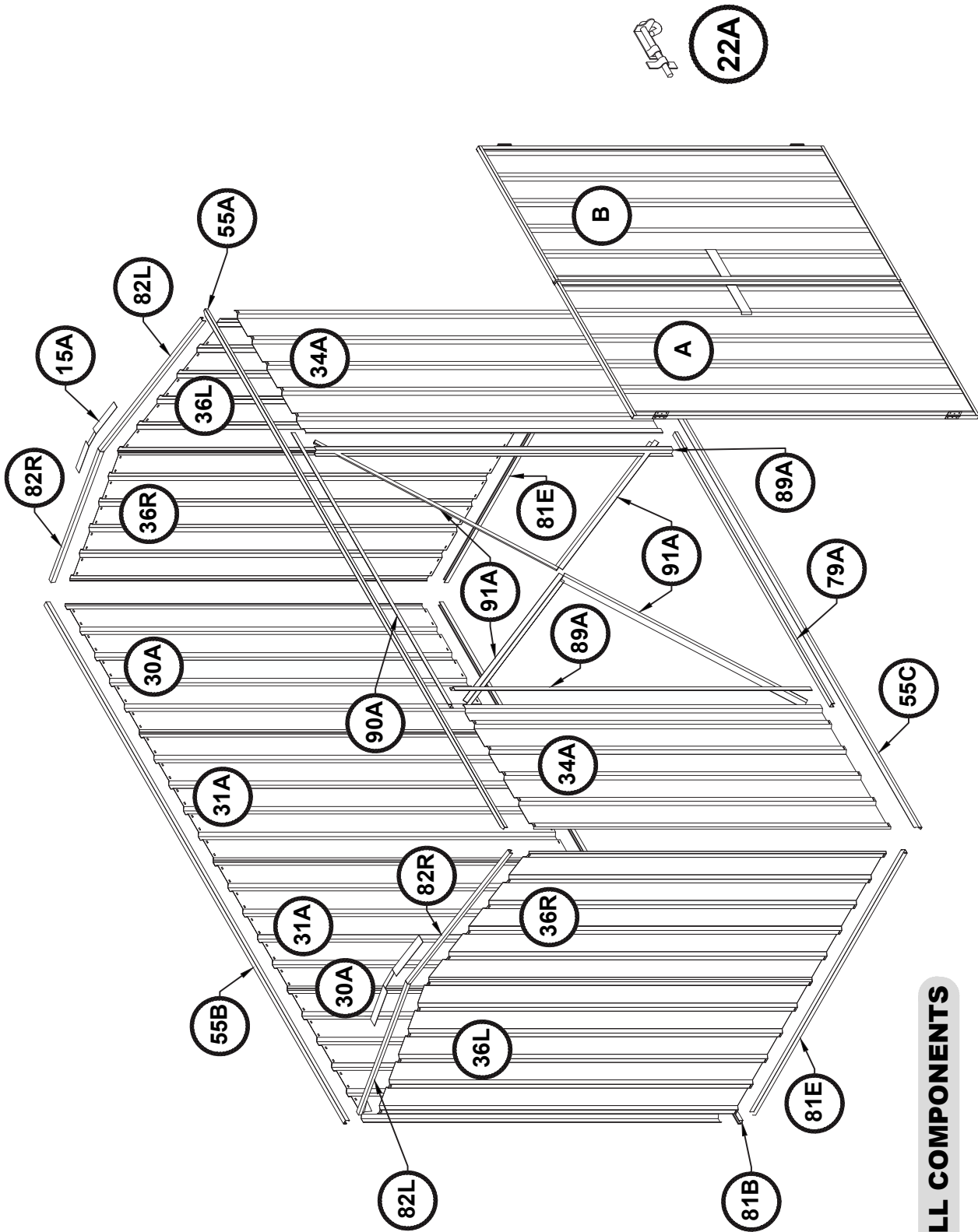

VIEW OF WALL COMPONENTS

ABSCO ASSEMBLY INTRODUCTION

The snaptite assembly system locks most perimeter channels to all roof and wall sheets without the need for tools and fasteners.

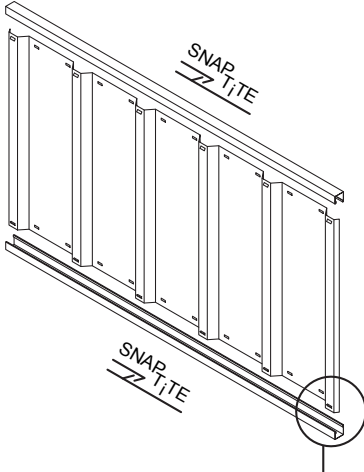

To pre-assemble the four wall panels and two roof panels, the perimeter channels are secured to the top and bottom of each panel using the snaptite system, as detailed on the following pages wherever you see the symbol.

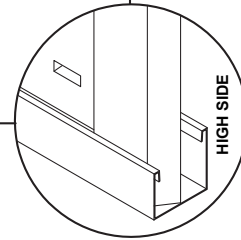
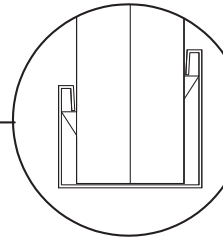
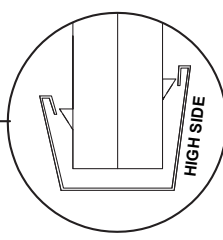
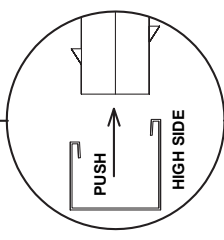
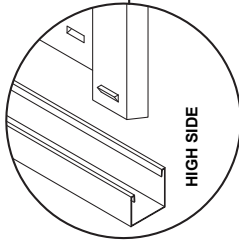
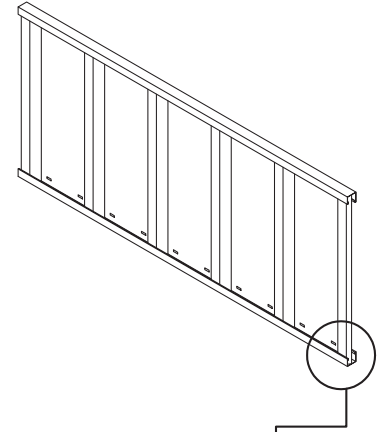

After joining sheets together, position channel over one end of the sheets, gently tapping it over the snaptite lugs, working along the sheets to the other end.

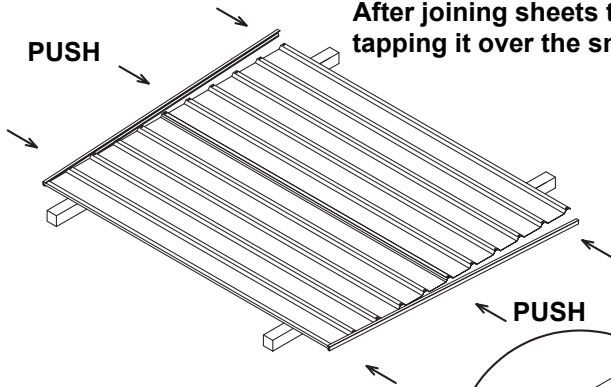

Each perimeter channel must finish flush with the edges of the sheets. The snaptite system allows adjustment for this process by simply tapping the channel along the sheets until each end is neatly flush. If you need to remove channels from the panels, pull the channel along the panel from opposing ends. You may need someone to help with this.

Position sheets on timbers, trestles or partly over edge of concrete slab.

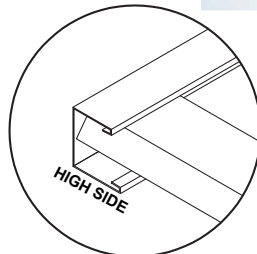

FASTENING SYMBOLS

 **D** Join components together by pre-drilling the holes first. Use one component as a template to mark where the holes are. Drill with 3mm drill bit.

 Join components together with one screw at this location only, as some channel sections have extra holes that are not required for this model of garden shed

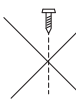
 Do not join components together at this location yet, as the screw may obstruct further assembly of other components



POP RIVETS



NUT & BOLT SET

REAR PANEL ASSEMBLY

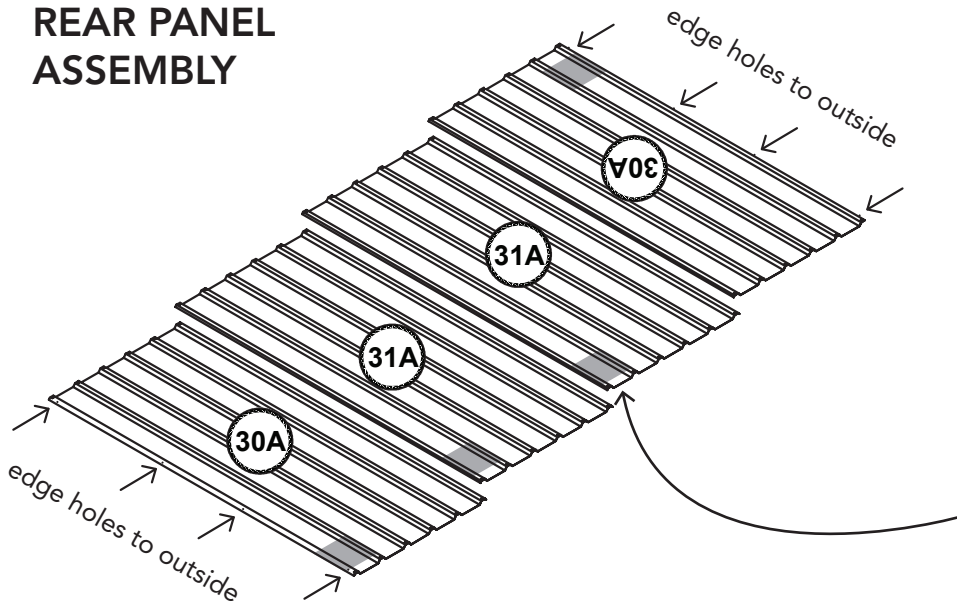

1. Overlap specified sheets as shown. Make sure ends are flush.

Where possible, have sheets orientated so printed part numbers are as shown.

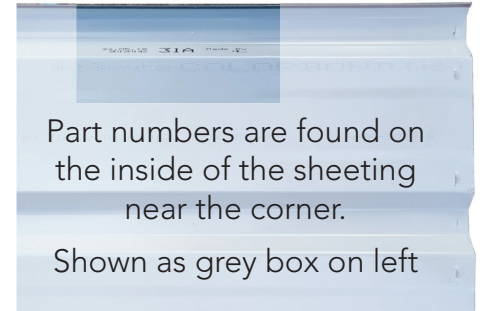

Part numbers are found on the inside of the sheeting near the corner.

Shown as grey box on left

2. Fasten with self tapping screws through prepunched sheet-to-sheet holes on overlap.

If you can't see bottom hole twist the sheet left or right.

Make a new hole with supplied drill bit if bottom hole is too far up or down the sheet or not found.

3. Attach the top and bottom channels using the SNAP-TiTE method.

Make sure you have the short side of the channel to the outside of the sheeting

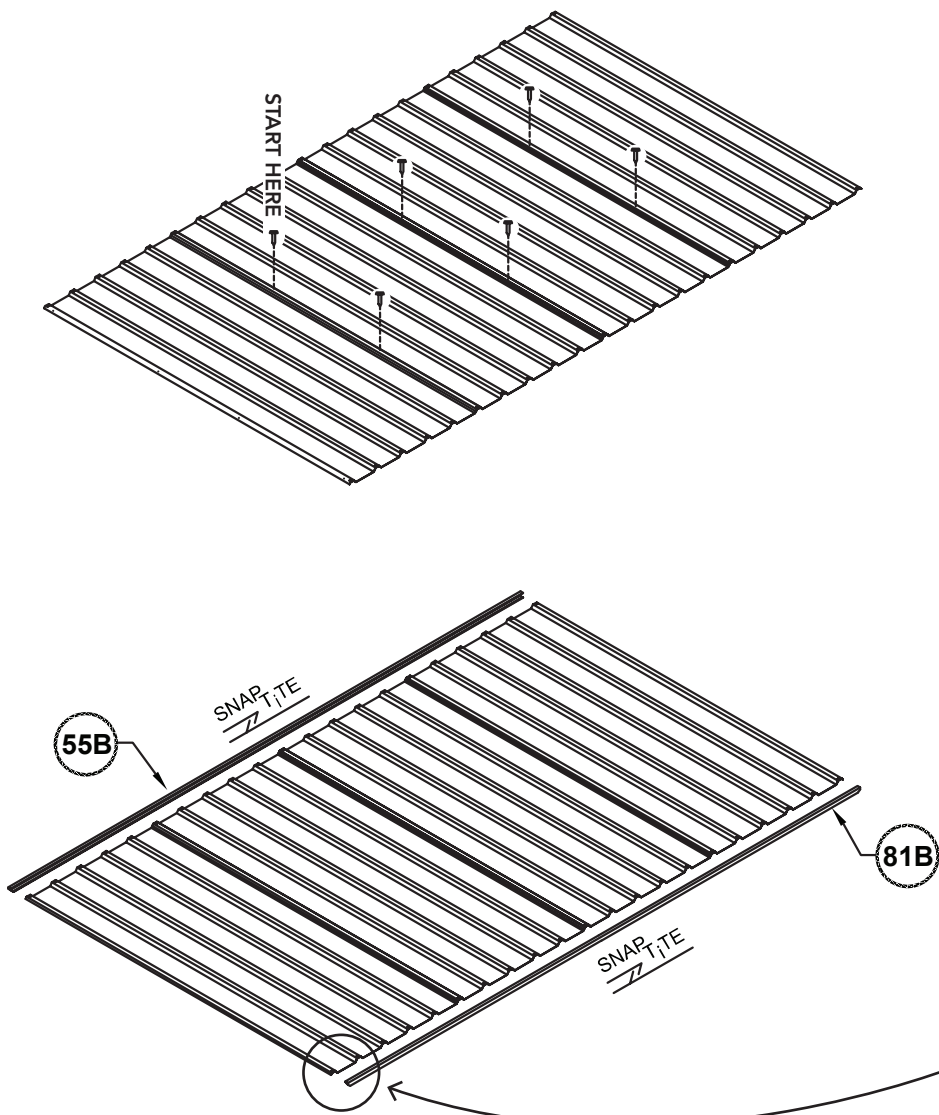
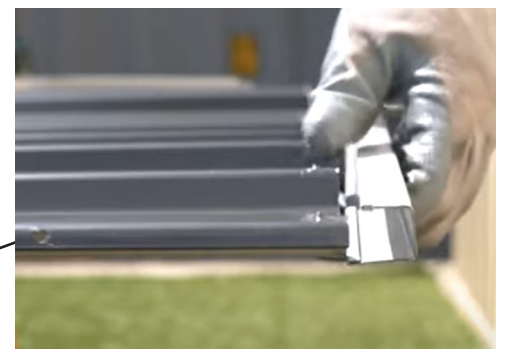

ROOF PANEL ASSEMBLY

2 completed panels are required.

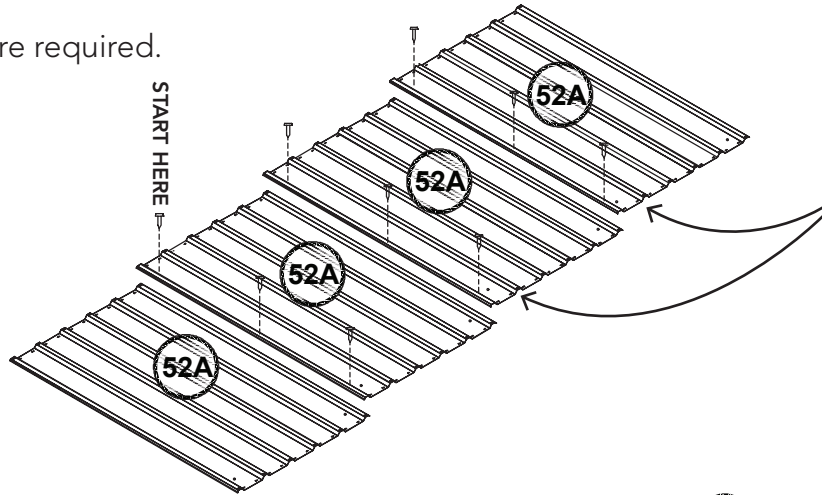

Orientate all sheets so the short ends with the holes are on the same side and are lined up.

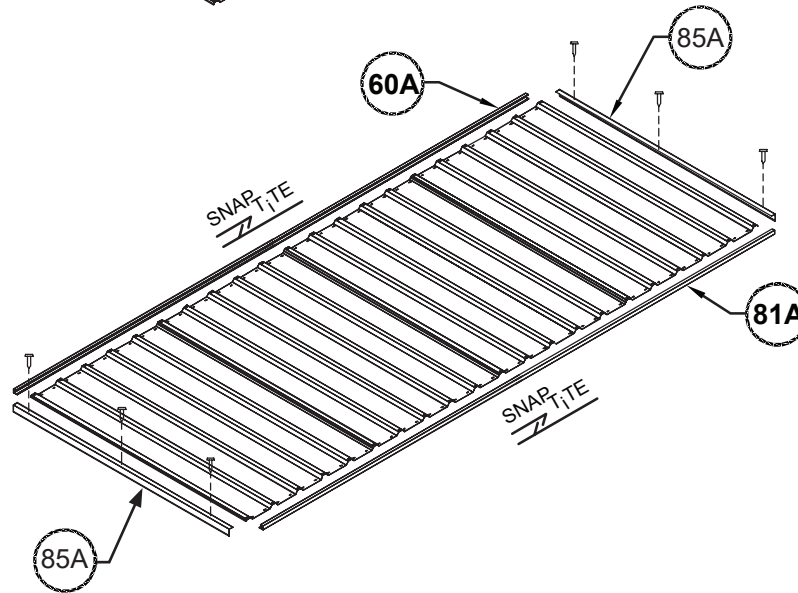

Fit 81A channel to edge of sheet with these holes.

This is the edge that will be screwed down on top of the wall in the final stage.

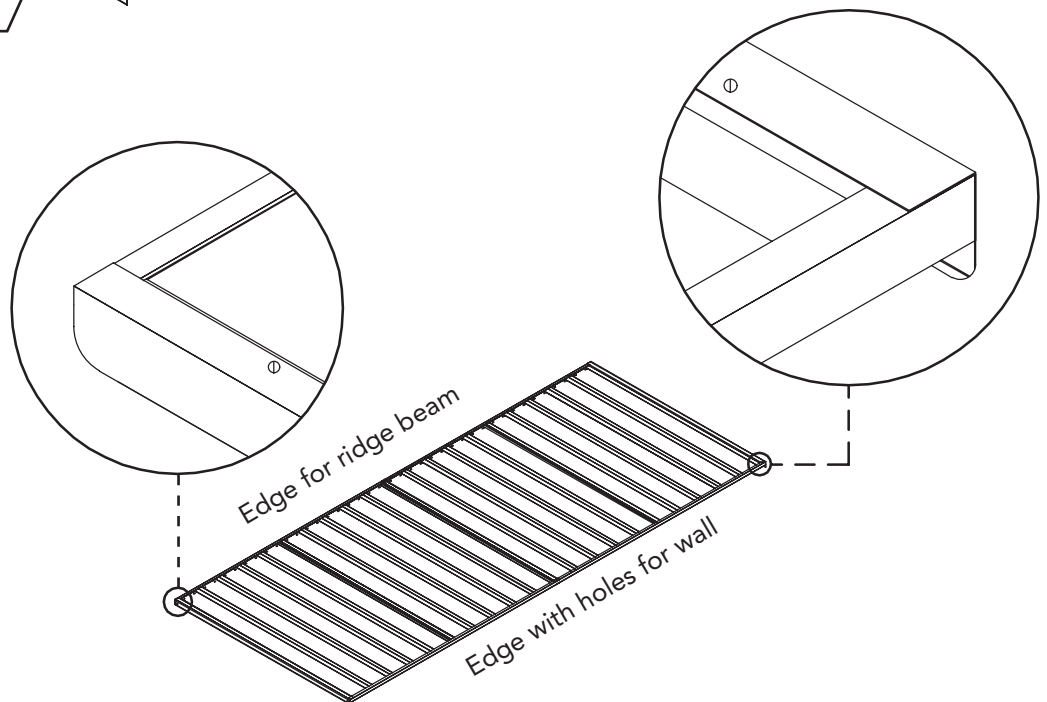

SIDE PANEL ASSEMBLY

2 completed panels are required.

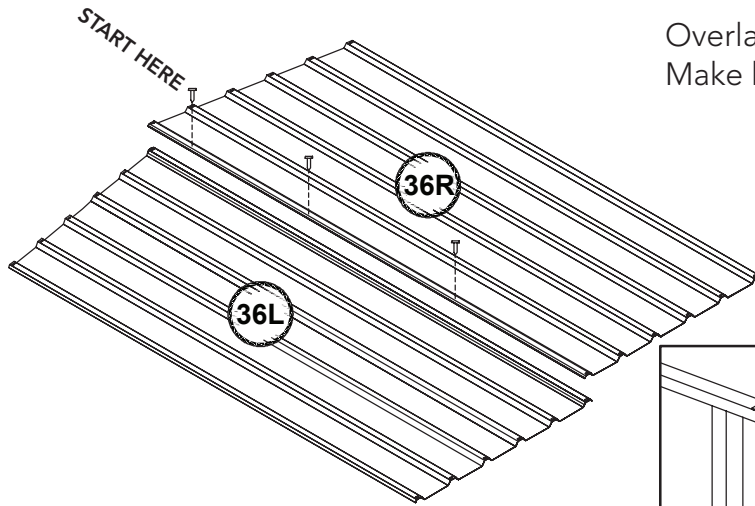

Overlap both sheets as shown.
Make bottom edges flush.

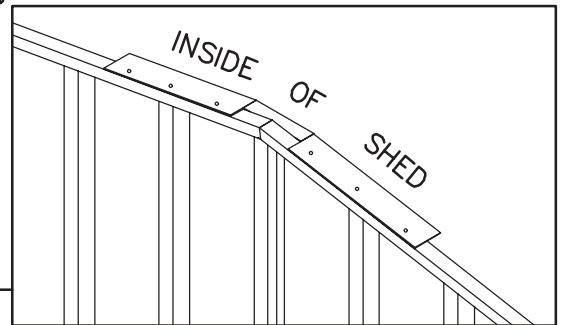

Trim the tip of each sheet to allow channels to fit hard up to the edge of the sheet.

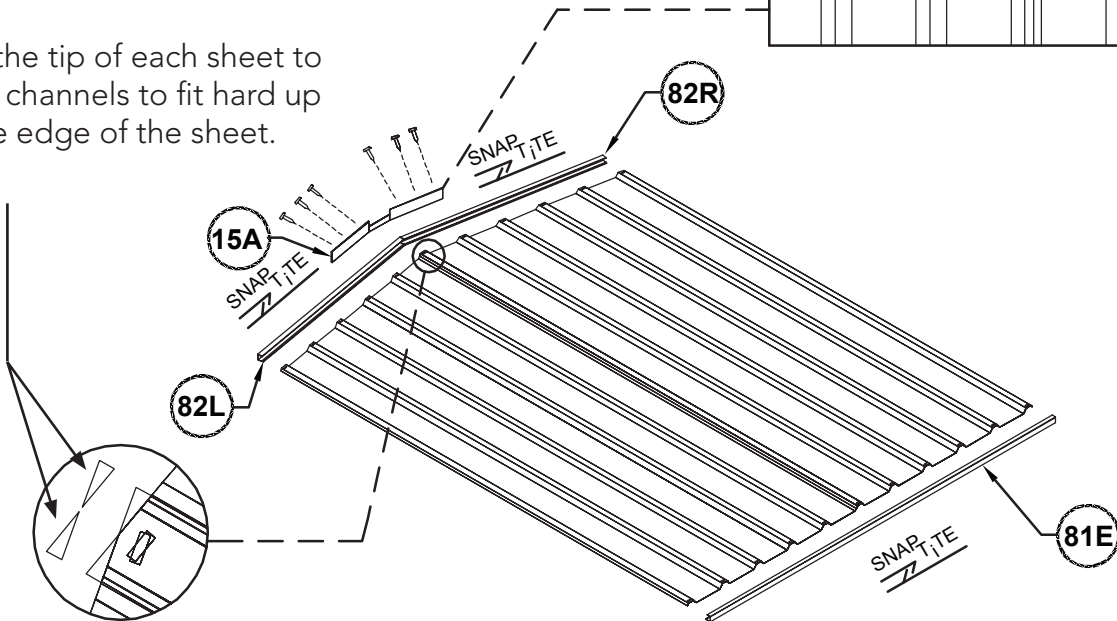

FRONT PANEL ASSEMBLY

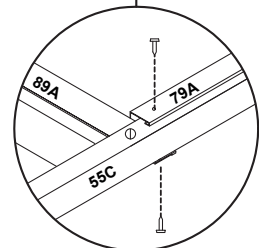
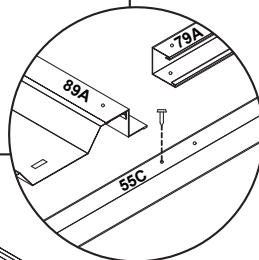
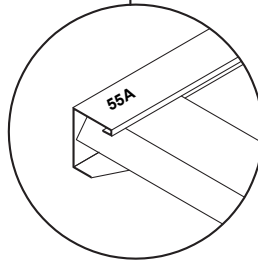
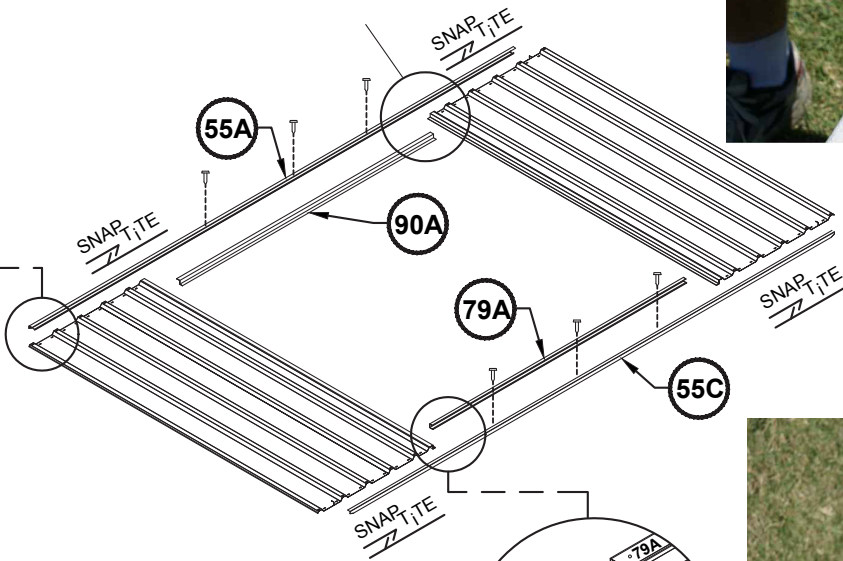
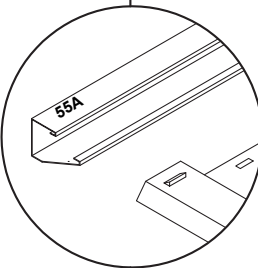
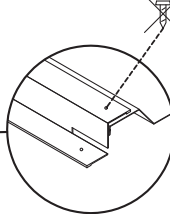
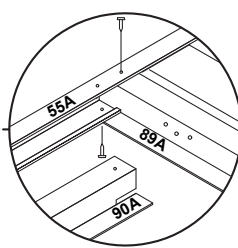
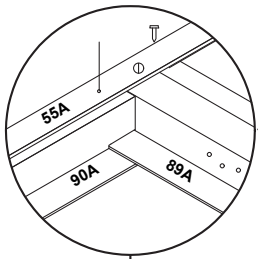
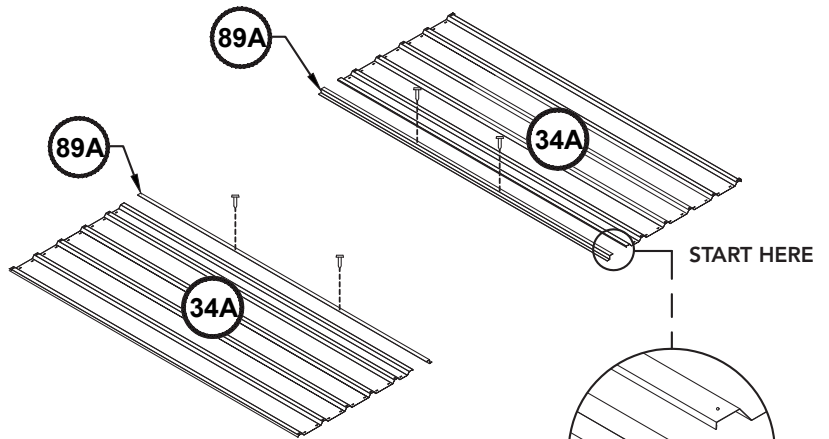

DOOR PANEL ASSEMBLY

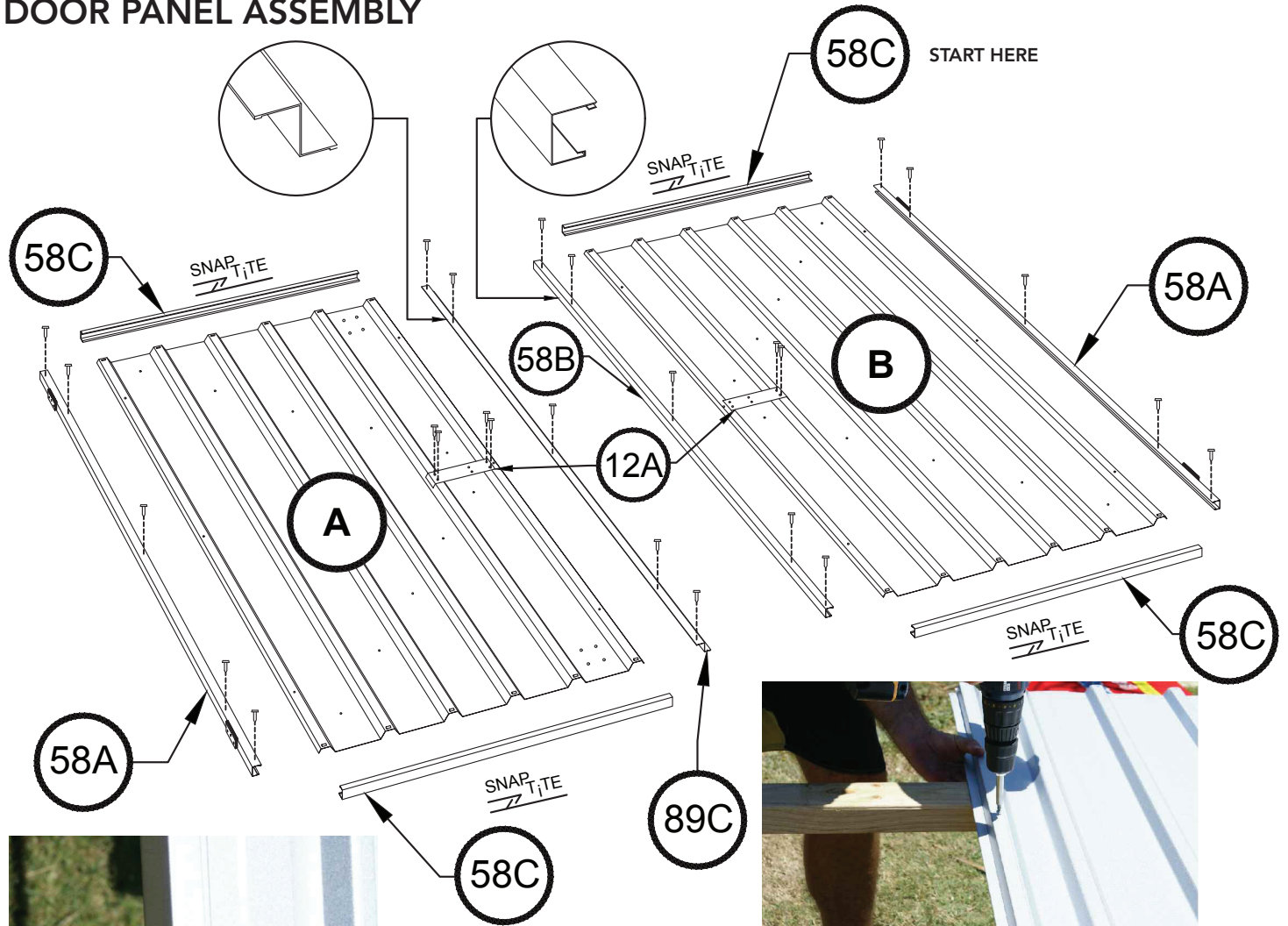

ALL VERTICAL DOOR CHANNELS ARE INSTALLED IN THE REVERSE DIRECTION IN COMPARISON TO HORIZONTAL DOOR CHANNELS

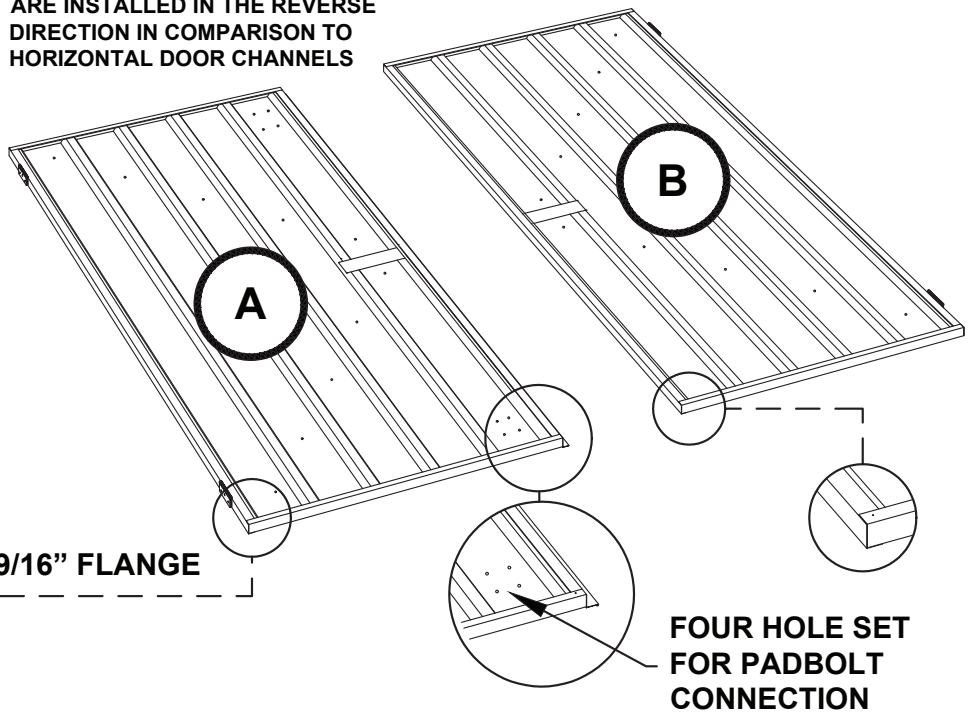
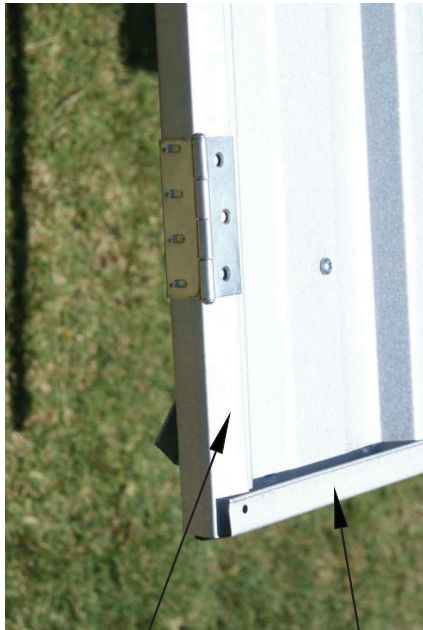

13/16" FLANGE

9/16" FLANGE

FOUR HOLE SET FOR PADBOLT CONNECTION

DOOR PANEL ASSEMBLY

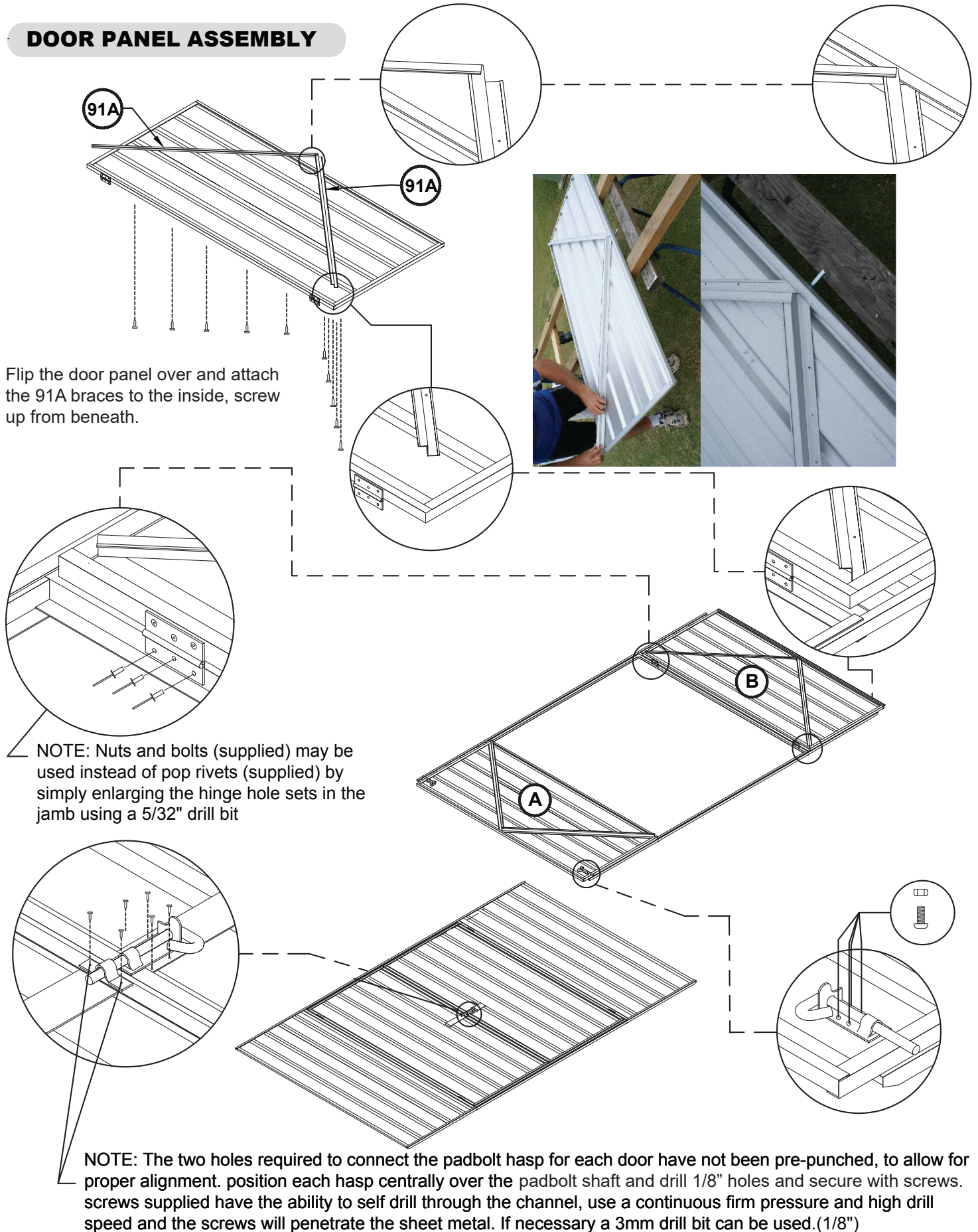

PANEL CONSTRUCTION

NOTE: Take care to ensure that all wall panels are not upside down. The top channels of each panel are pre-punched for attaching roof sheeting.

Suggested assembly order

- Front
- Sides
- Rear

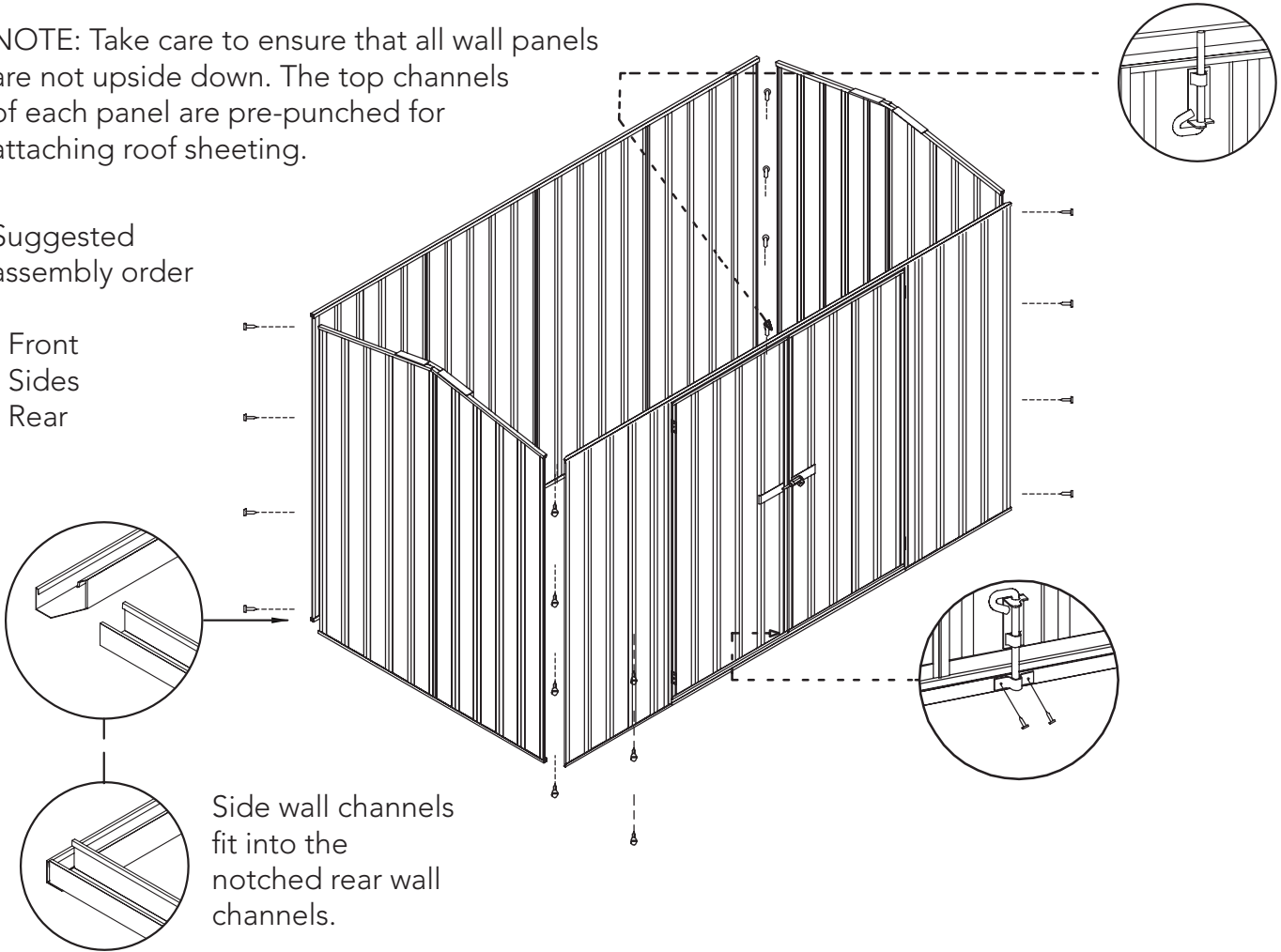

Side wall channels fit into the notched rear wall channels.

Next, prepare a single roof panel as shown.

Slide ridge beam down onto roof panel. Align shared holes and secure the panel with self tapping screws from underside

Roof panel with ridge beam ready for assembly.

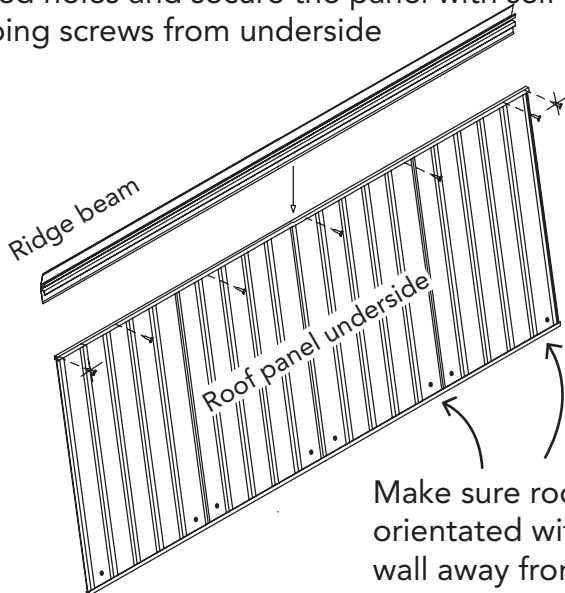

Make sure roof panel is orientated with holes for the wall away from ridge beam

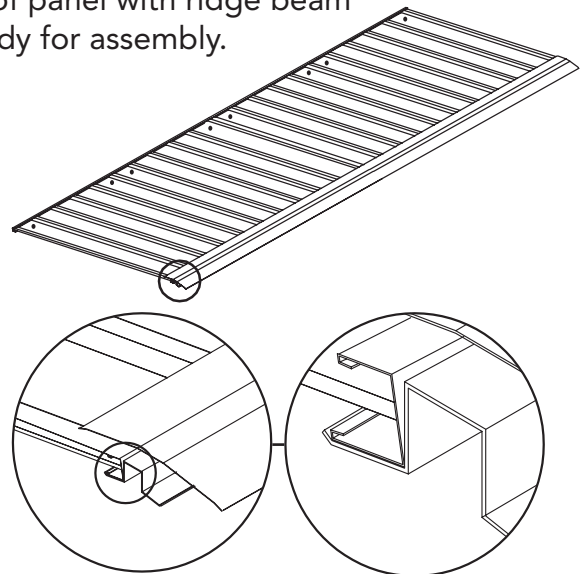

Roof panel channel should be flush with end of ridge beam

8. ROOF CONSTRUCTION



INSIDE VIEW OF FIXING

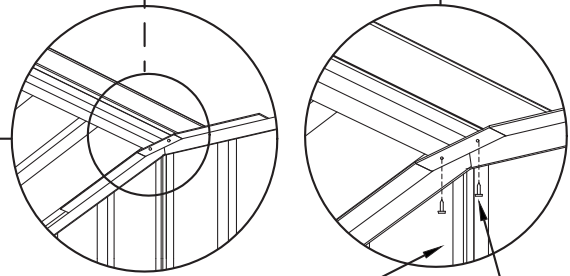

SECURE PEAK BRACE TO RIDGE BEAM AND ROOF PANEL WITH ONE SCREW AT EACH END

MOVE THE OTHER ROOF PANEL INTO POSITION AND SECURE PEAK BRACE TO RIDGE BEAM AND ROOF PANEL WITH ONE SCREW AT EACH END

SLIDE THE ROOF PANEL INTO POSITION, AND SECURE WITH ONE SCREW AT EACH CORNER ONLY AT THIS STAGE

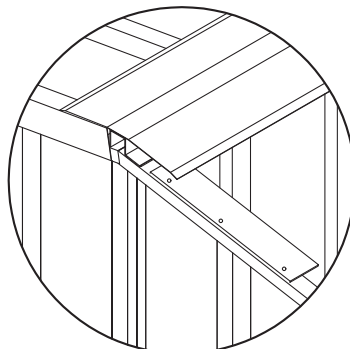
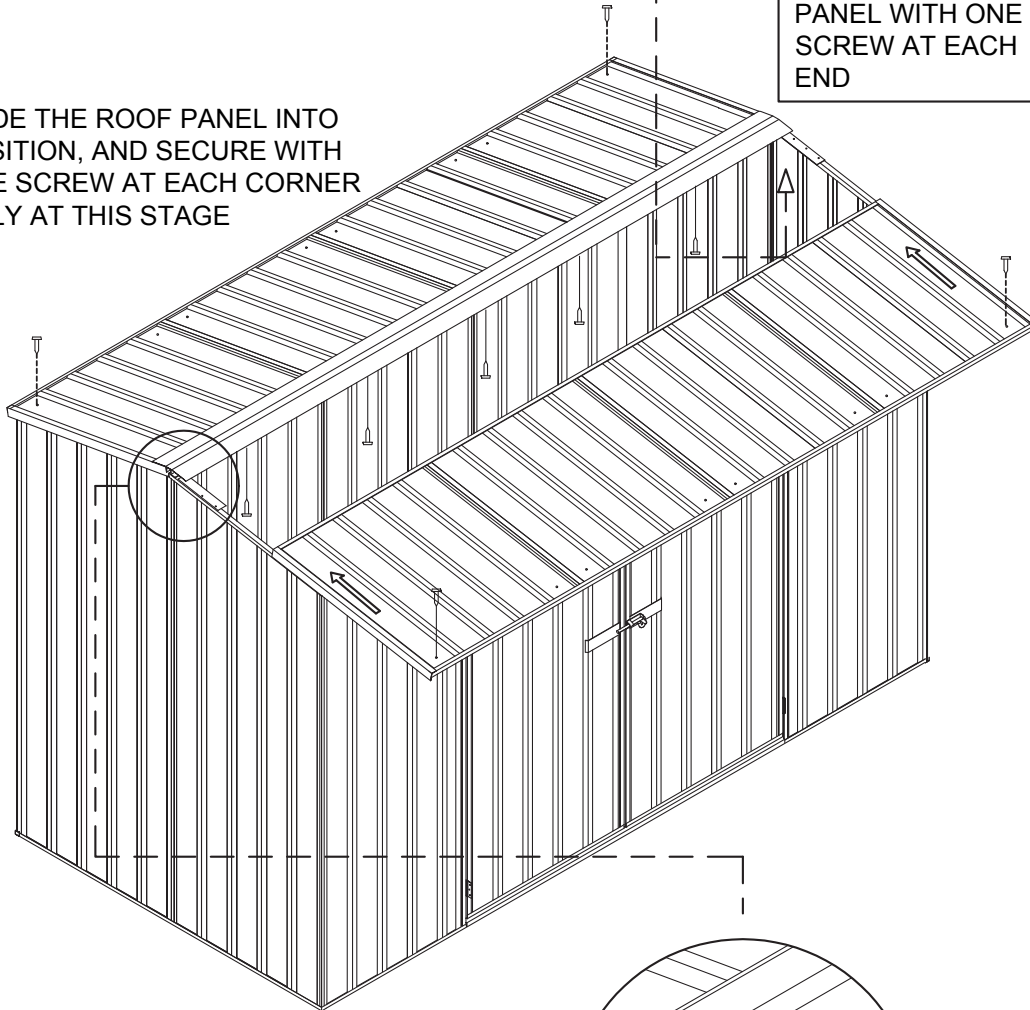

FINAL CONSTRUCTION

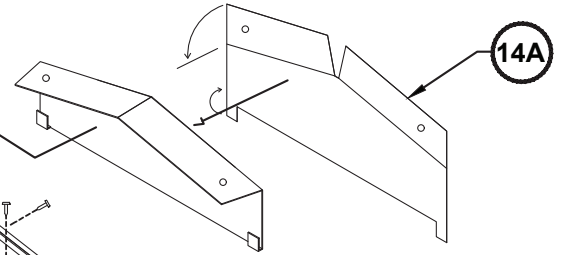
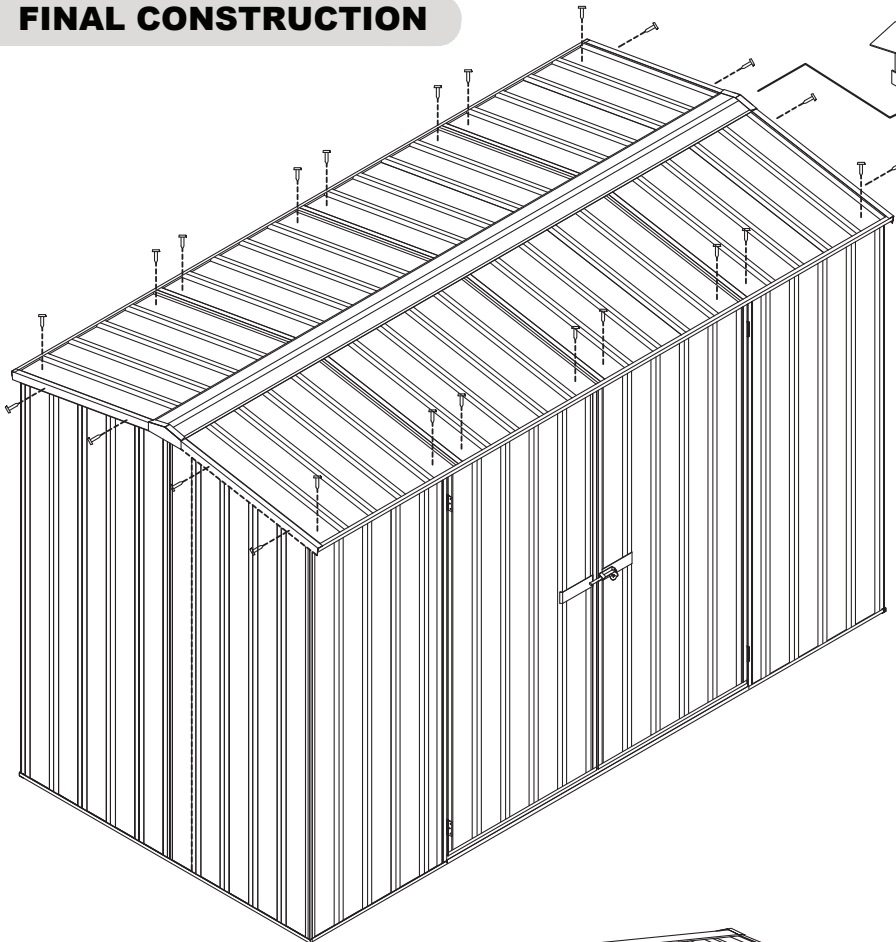

BEND THE TOP AND BOTTOM FLANGES AS SHOWN, THEN HOOK THE BOTTOM FLANGES UNDER THE TOP CHANNEL AND SCREW THE TOP FLANGES FOR BOTH AS SHOWN GABLE CAPS

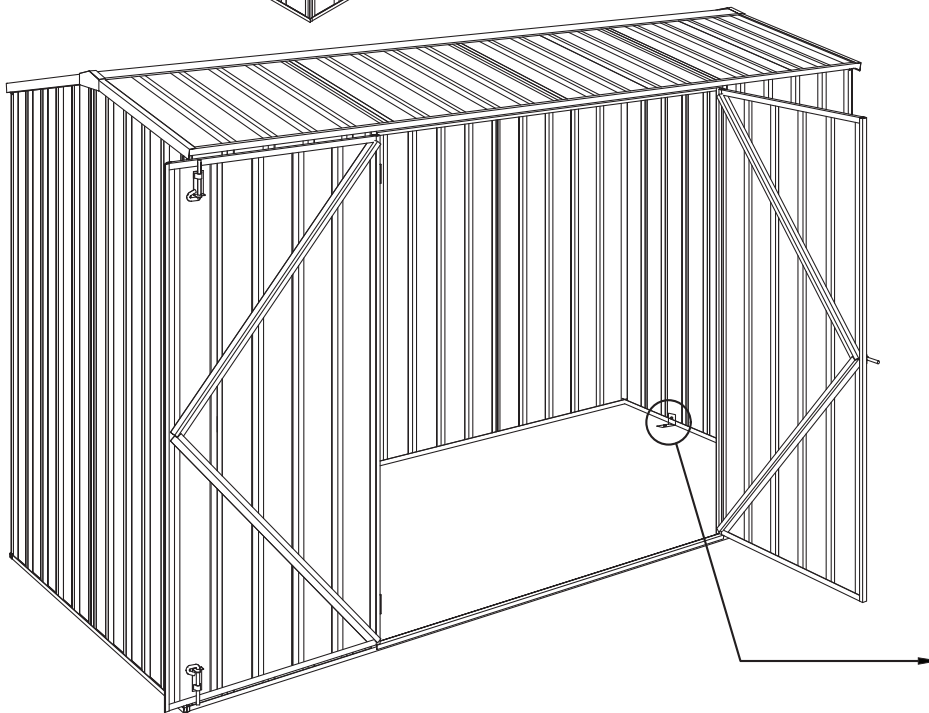

ANCHORING OF SHED

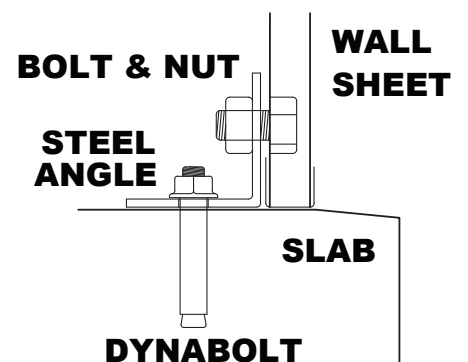
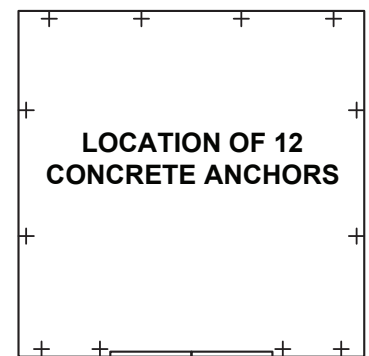

- EACH ANCHOR CONSISTS OF ONE NUT, BOLT, DYNABOLT AND STEEL ANGLE
- DRILL A 25/64" HOLE INTO THE WALL SHEET
- DRILL A 25/64" HOLE INTO THE CONCRETE

REINFORCING ROOF

INSTALL ADDITIONAL SCREWS ALONG THE UNDERSIDE OF THE RIDGE BEAM, CENTERED IN EVERY SECOND PAN OF THE ROOF SHEETING AS PICTURED.



THESE POSITIONS DO NOT HAVE PRE-PUNCHED HOLES SO USE THE SUPPLIED DRILL BIT TO PREDRILL HOLES THROUGH THE RIDGE BEAM, THE ROOF PANEL CHANNEL INSIDE IT AND THE ROOF SHEET.

FIX USING A FAST001 SELF TAPPING SCREW IN EACH OF THESE POSITIONS.

EXPORT PRODUCT WARRANTY AGAINST DEFECTS

Congratulations on your purchase of an ABSCO SHED

ABSCO SHEDS, including garden sheds, garden beds, aviaries, storage units, garages, awnings and carports are made using high quality Australian made steel.

We are pleased to advise we warrant that the steel coating will not rust, crack, flake peel or blister for 12 years from date of purchase.

This warranty does not apply to surface deterioration of panels caused by 'Swarf' (Tiny particles of steel debris left from cutting, grinding or drilling operations) that has not been removed after building construction, or as a result of contact with damp soil, chemicals, fertilisers or other corrosive substances.

This warranty covers any Absco product used for normal domestic use and installed in accordance with the installation instructions.

This warranty does NOT cover Damage caused by storms, wind, rain, snow or poor foundations.

This warranty does NOT cover ABSCO products installed in severe coastal, industrial or other highly corrosive environments. The warranty does not cover fasteners (screws, nuts, bolts, rivets, hasps or sliding padbolts).

The warranty is limited to replacement and delivery of components and does not include any labour or installation costs. The benefits given by the warranty are in addition to your other rights and remedies under a law in relation to the goods or services to which the warranty relates.

In the unlikely event a warranty claim is made, it must be supported by photographic evidence and details of the defect, including component part numbers, together with proof of purchase documentation (or on-line registration of purchase) and forwarded to the address below. Upon receipt of the warranty claim, the Customer Service Manager will contact you within three business days to advise you of the assessment outcome of the claim, which may include your expenses incurred in making the claim.

THE CUSTOMER SERVICE MANAGER, ABSCO SHEDS, PO BOX 119 ACACIA RIDGE QLD AUSTRALIA 4110

PHONE: +1 (866) 788 3046

EMAIL: warranty@absco.com.au

Issued 16 July 2019