

**This shed kit can be built two ways!**



Config A

Choose roof slope direction to suit your site.



Config B

Please make a decision now and read ahead to get a good understanding of the steps required before beginning construction.

- Pages 1 to 14 are common
- Pages 15 to 19 are Config A specific
- Pages 20 to 25 are Config B specific

When laying a concrete slab for your shed, it is best practise to have a rebated edge to prevent water ingress.

Rebated section is 1" high and inset 3" on all sides from the overall slab base dimensions

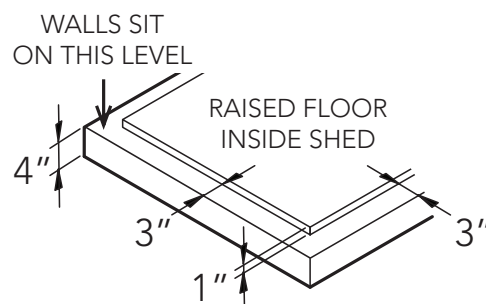

Overall slab base dimensions for this model are as shown above.

Illustration not to scale.

**GENERAL INSTRUCTIONS**

- Before commencing any assembly, read through these instructions in detail to gain a thorough understanding of assembly methods and associated details.
- Unpack the carton and carefully identify and check off all the parts against the parts described and illustrated on "COMPONENTS PACKING LIST" pages.

**SITE PREPARATION**

- The site for the shed must be level. An uneven surface may result in misalignment of parts.
- The shed shall be erected on top of a reinforced concrete slab and anchored down appropriately illustrated on "FINAL CONSTRUCTION" page.

**SAFETY NOTES**

- Some parts may have sharp edges. It is advisable to wear gloves when handling these items and safety glasses if drilling holes. Sensible shoes are highly recommended.
- Do not erect your shed in windy conditions.
- Ensure that the shed is securely anchored to a solid foundation immediately after construction is completed.
- It is highly recommended to erect the shed with two or more people.
- Do not sit, stand or walk on the roof of your shed.

**RECOMMENDED**



Personal protective equipment for tools



Hand Protection



Enclosed Shoes



Raised work surface. EG Sawhorses and timbers



Heavy and/or bulky. Multi-person lift or mechanical aid.

**TOOLS REQUIRED**

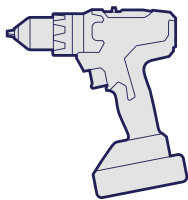

Cordless drill

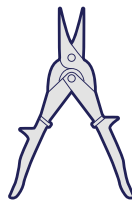

Tinsnips

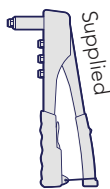

Pop riveter



Ladder

metal & masonry drill bits to suit anchor fasteners

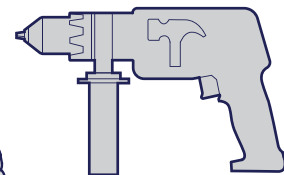

Hammer drill



Shifter

**NUMBER OF PEOPLE REQUIRED**



2 people

**NUMBER OF HOURS REQUIRED**



Approx. 5 hours

**ASSEMBLY DIFFICULTY**





Basic





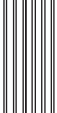
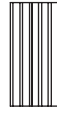
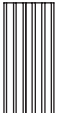
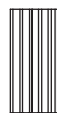
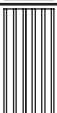
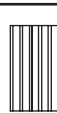
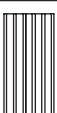

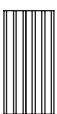
Complex

**COMPONENTS LIST**

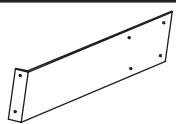
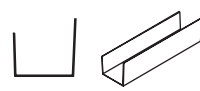
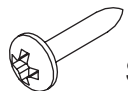
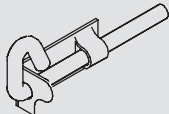
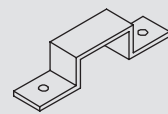

Nominal sheet widths are shown +/- 1/8" is within tolerance

QTY	DESCRIPTION	PART #	CHK	QTY	DESCRIPTION	PART #	CHK
1	 STEEL SHEET 80" x 30.4"	H31		1	 STEEL SHEET 70.3" x 30.4"	31A	
1	 STEEL SHEET 80" x 30.4"	H3L		1	 STEEL SHEET 70.3" x 28"	34A	
1	 STEEL SHEET 80" x 30.4"	H3R		1	 STEEL SHEET 67.9" x 30.4"	DOOR B	
3	 STEEL SHEET 70.3" x 30.4"	30A		3	 STEEL SHEET 63.4" x 30.4"	43S	
1	 STEEL SHEET 70.3" x 30.4"	30G					
1	 GABLE LEFT 58"	16L		1	 GABLE RIGHT 58"	16R	

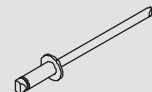
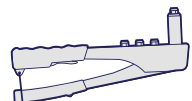
**FITTINGS PACK**

QTY	DESCRIPTION	PART #	CHK	QTY	DESCRIPTION	PART #	CHK
1	 DOOR STRAP	12A		6	 CHANNEL JOINER 7.8"	CSJ	
8	 SELF TAPPING SCREW 8G X 3/4"	FAST 013		1	SINGLE DOOR FITTINGS PACK SHOWN BELOW IN GREY	PSTK SGL	
1	 DOOR PADBOLT	FAST 006		1	 PADBOLT HASP	FAST 007	
1	 1/8" DRILL BIT	DRILL		1	 PHILLIPS DRIVER BIT	FAST 038	
1	 SELF TAPPING SCREW 8G X 3/8" PACK QTY 220	FAST 001		6	 POP RIVET	FAST 009	
1	 POP RIVETER	RIVET GUN		2	SET OF 4 ANCHORS ANGLE / NUT&BOLT / CON- CRETE ANCHOR	ANCH OR4	

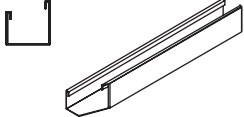
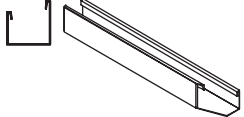
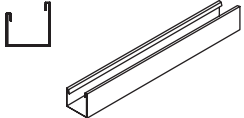
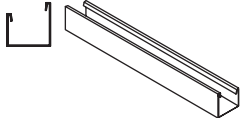
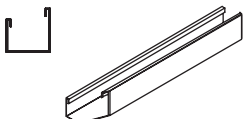
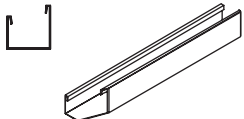
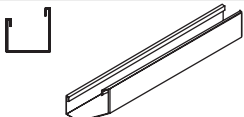
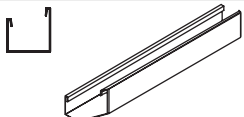
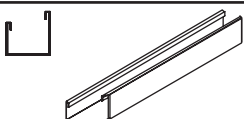
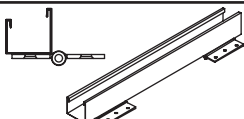
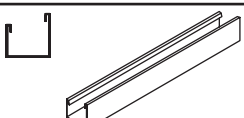
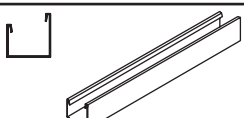
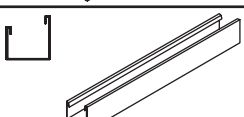
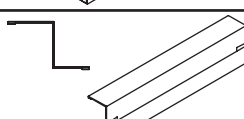
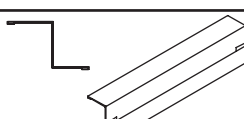
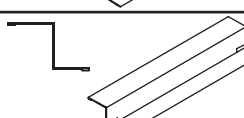
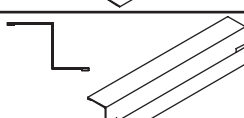
**COMPONENTS LIST**

QTY	DESCRIPTION	PART #	CHK	QTY	DESCRIPTION	PART #	CHK
4	 CHANNEL 44.3"	81DL		4	 CHANNEL 44.3"	81DR	
2	 CHANNEL 44.3"	81CL		2	 CHANNEL 44.3"	81CR	
1	 CHANNEL 59.5"	77E		1	 CHANNEL 59.5"	77J	
1	 CHANNEL 59.5"	77G		1	 CHANNEL 59.5"	77K	
1	 CHANNEL 70.3"	80A		1	 CHANNEL 67.9"	58A	
2	 CHANNEL 30.4"	58C		1	 CHANNEL 67.9"	58B	
1	 CHANNEL 30.7"	79C					
1	 JAMB 70.3"	89A		1	 JAMB 30.7"	90C	
1	 JAMB 70.3"	89B		2	 JAMB 44"	91A	
2	 LIP 63.4"	88J		2	 LIP 10.2"	88P	

## SNAPTITE ASSEMBLY GUIDE

The Snaptite Assembly System locks end channels to all roof and wall sheets without the need for tools and fasteners.

To assemble each panel, the perimeter channels are secured to the top and bottom of each panel. Gently tap the channel over the SNAPTITE lugs on the sheet, working along the sheet.

Each perimeter channel must finish flush with the edges of the sheets. Simply tap the channel along the sheets until each end is neatly flush. If you need to remove channels from the panels, slide it off from the side.

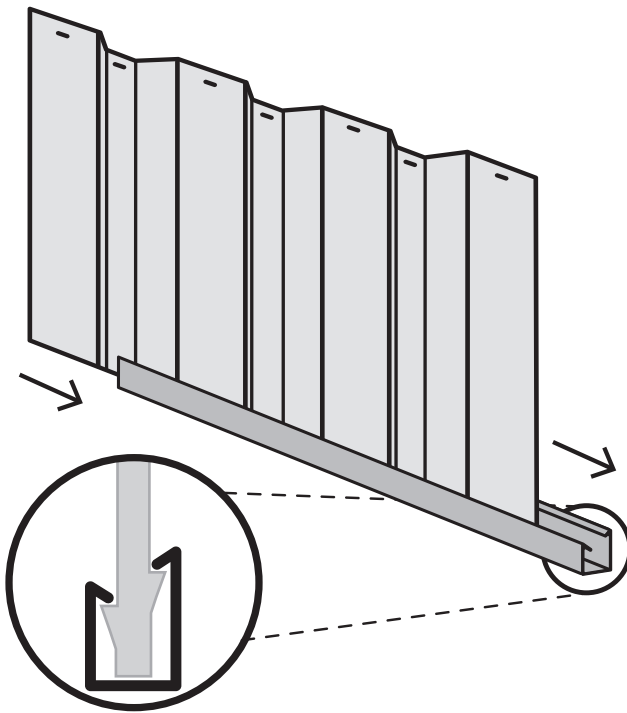

**SNAPTITE**  
World's Easiest Assembly System  
*UNIQUE PATENTED SYSTEM*

Channel locks the shed panel into position without the need for screws!

### FASTENING SYMBOLS

**SNAPTITE**

Secure channel to sheeting by SNAPTITE fastening method.



Join components together with one screw at this location only, as some channels have extra holes that are not required for this model of shed.

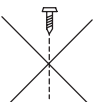

Do not join components together at this location yet, as the screws may obstruct further assembly of the other components.



Join components together by pre-drilling the holes first. Use one component as template to mark where the holes are and drill with a 1/8" drill bit.



1/8" pop rivet



3/16" nut and bolt set.

## Guide on Joining Spliced Channels

The text marked on all parts must be shown on the same side as each other



**Step 1.**  
Position the channels and the CSJ joiner so the centre of the CSJ is in line with the end of each channel to be joined together.

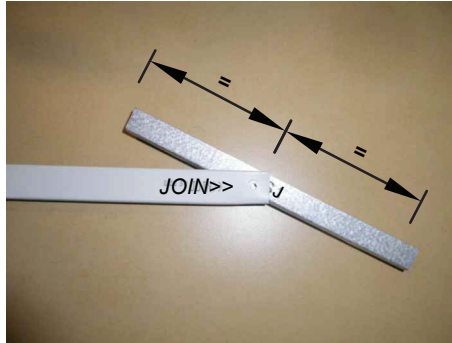

**Step 2.**  
Join the first channel to the CSJ by inserting the centre of the CSJ, on an angle, to the end of the channel where the JOIN>> text is marked.

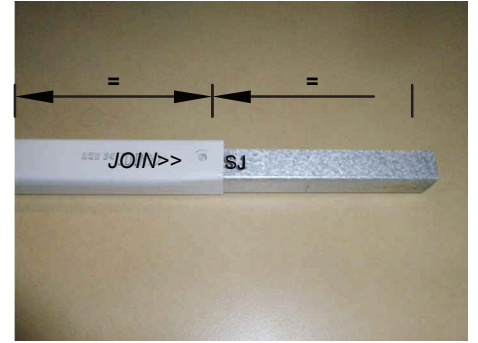

Push down one side of the CSJ until you hear a 'click'.

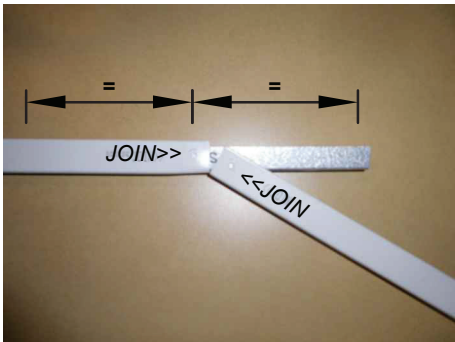

**Step 3.**  
Join the second channel to the CSJ by positioning the <<JOIN of the channel at the centre of the CSJ, on an angle. Push the CSJ into the channel until you hear a 'click'.

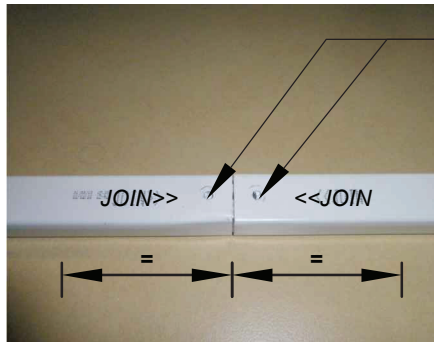

**Finished Channel.**  
The joined channels should now look like the picture with the CSJ positioned equally inside of the joined channels.

Drill out holes with 1/8" drill bit in CSJ to match the holes in channel. Drilling of screws on the joined channels is being done after sheets are locked on the spliced channels.

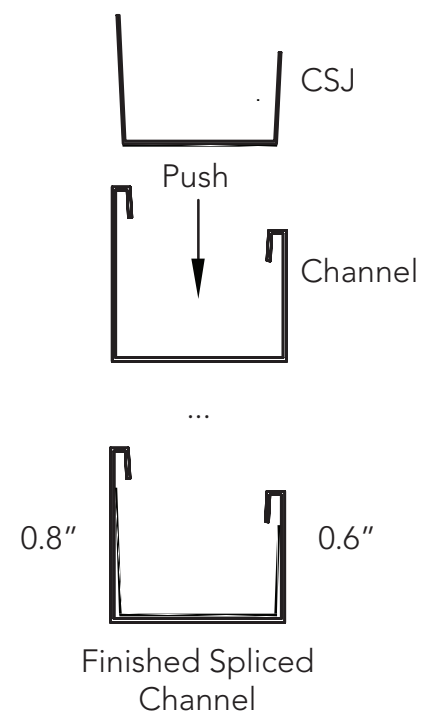

## PRE-ASSEMBLY OF SPLICED CHANNELS

Join together 12 x channel sections using 6 x channel joiners (Part CSJ)

NOTE: Some channels may have holes in them - You will need to redrill holes where CSJ joining channel covers them.

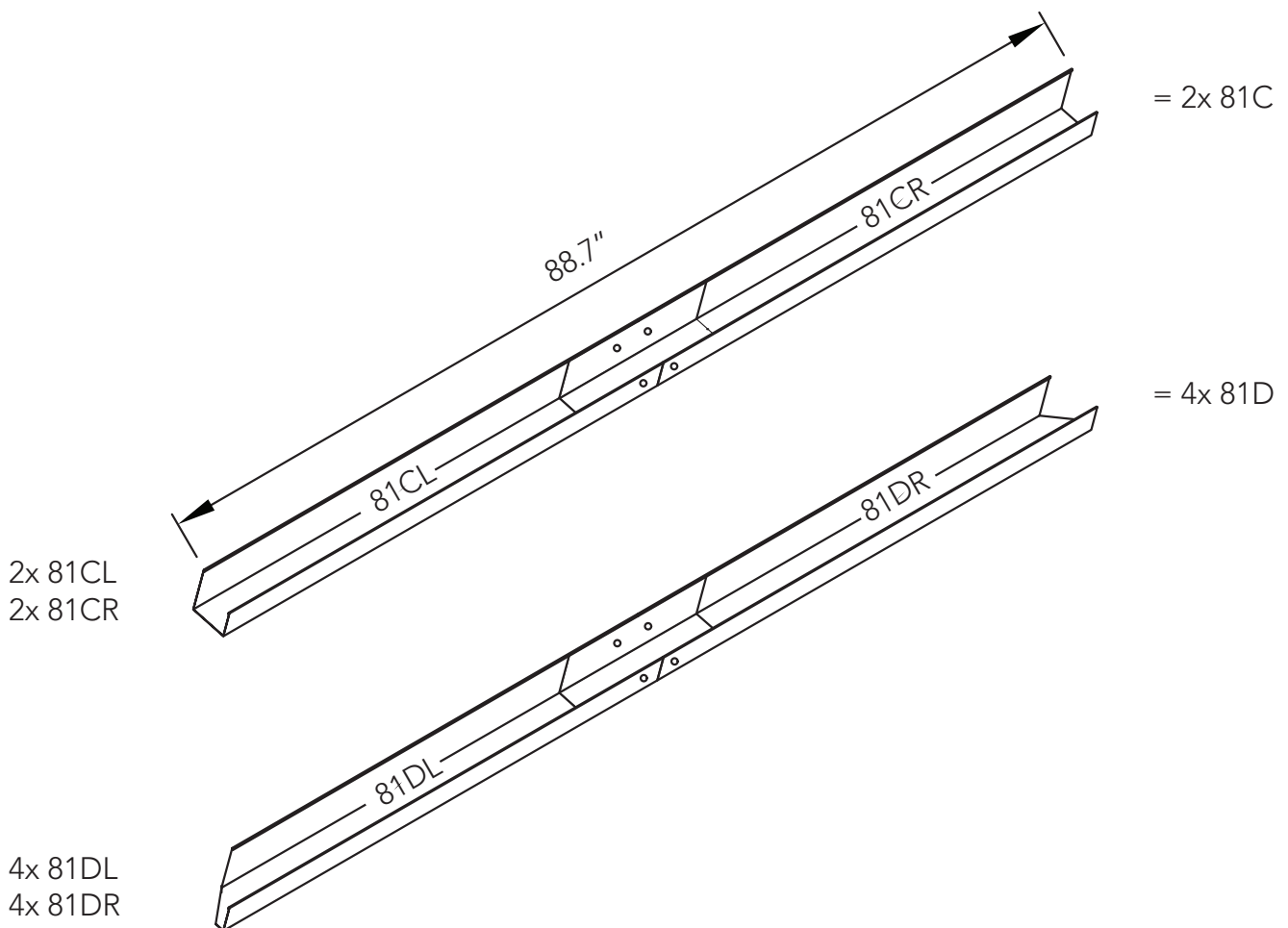



## REAR PANEL ASSEMBLY

1x required.

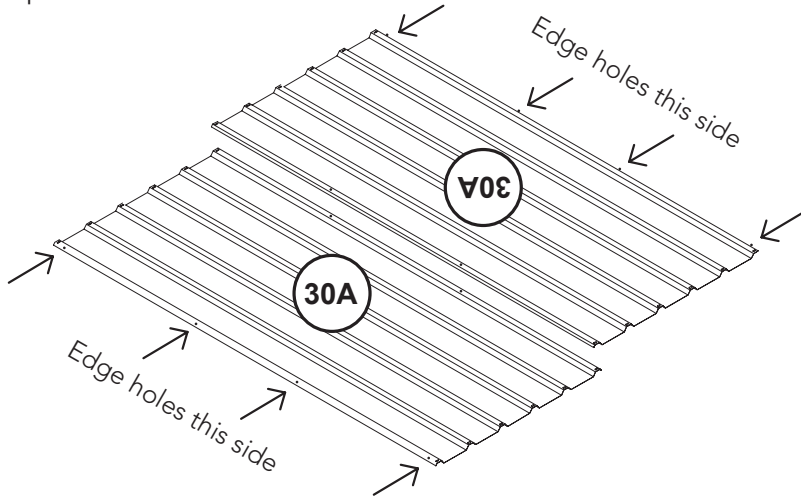

**1.** Overlap two 30A sheets by one rib as shown.

Turn one sheet so edge holes are to the outside as pictured.

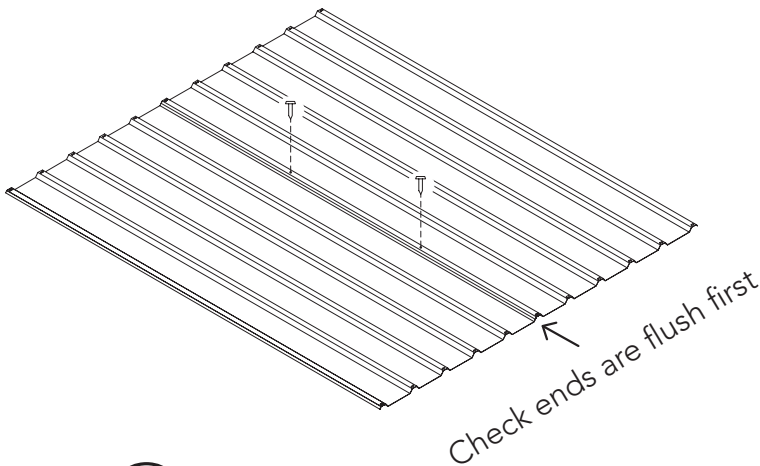

**2.** Fasten with 3/8" self tapping screws **FAST001** through prepunched sheet-to-sheet holes on overlap.

If you can't see bottom hole twist the sheet left or right.

Make a new hole with supplied drill bit if bottom hole is too far up or down the sheet or not found.

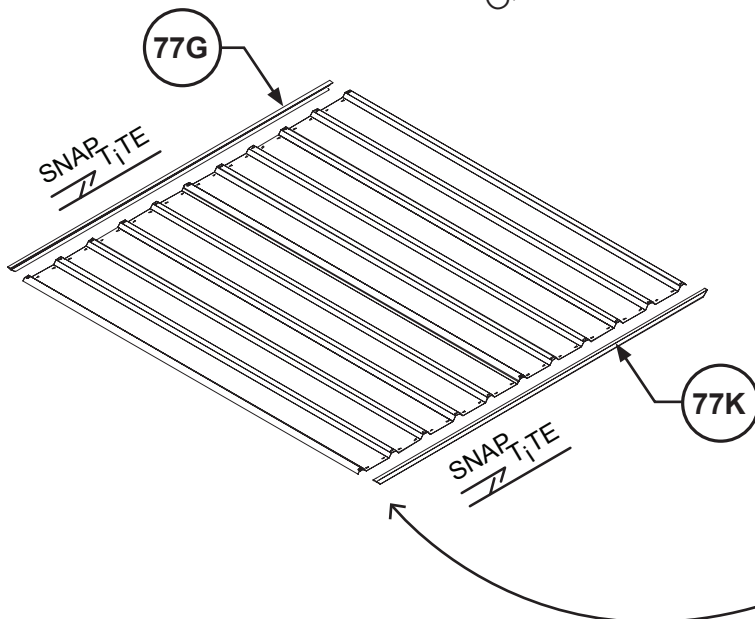

**3.** Attach the channels using the SNAP-TITE method.

Make sure you have the shorter, 0.6" side of the channel to the exterior of the sheeting

- We'll attach the gable panel in a later step -



## ROOF PANEL ASSEMBLY

1x required.

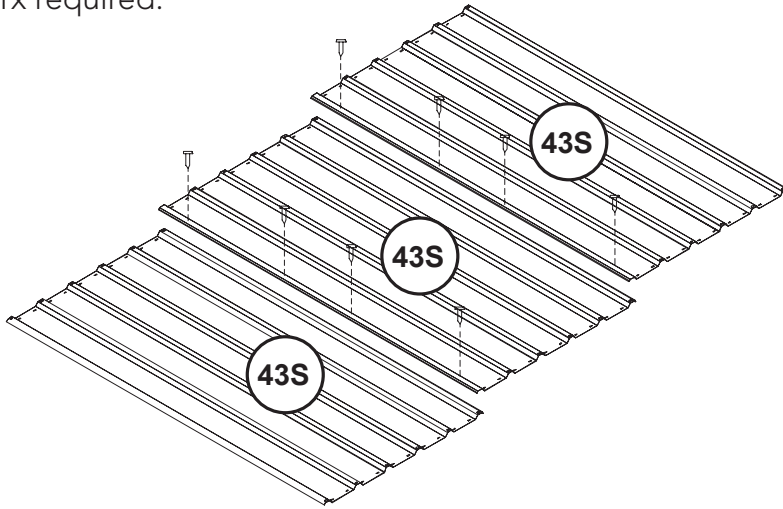

1. Layout and overlap sheets by one rib as shown.

2. Use 4x 3/8" self tapping screws FAST001 per overlap, through the pre punched holes.

3. Attach the front and rear channels using the SNAP-TiTE method.

Make sure you have the shorter, 0.6" side of the channel to the top of the sheeting

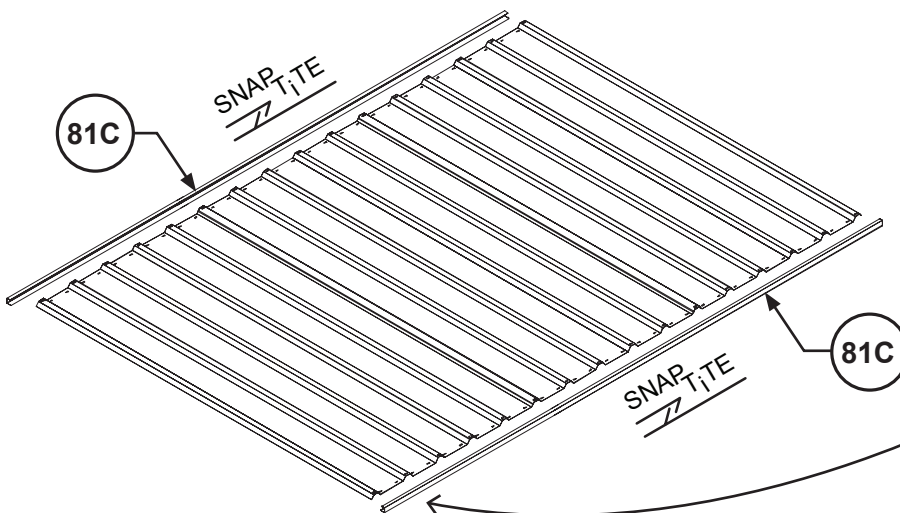

4. Now both channels are attached, fasten their L&R pieces to the CSJ with a 3/8" self tapping screw FAST001 in each top hole.

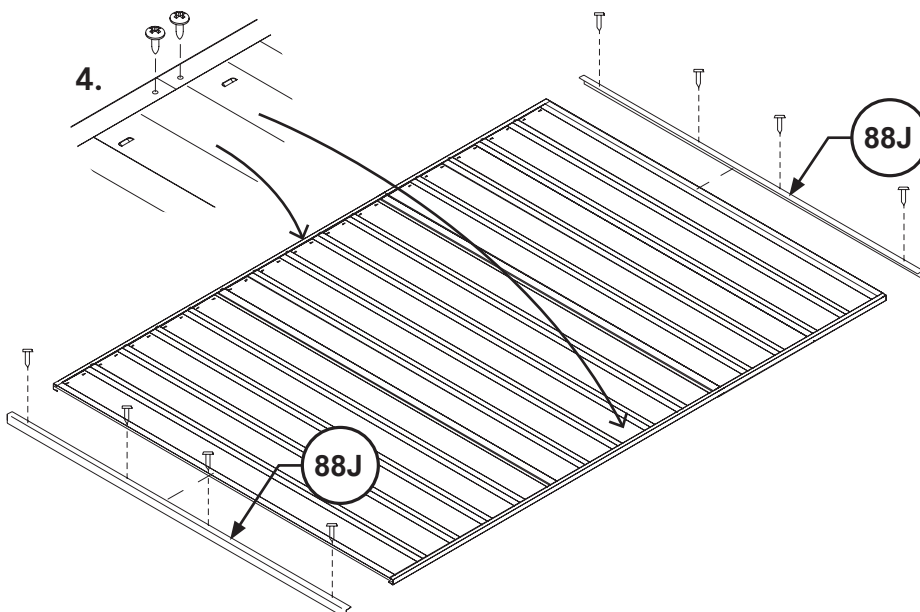

5. Take both **88J** lips and place on top of the sheet and inside both channels. Make sure the shorter face is to the top.

Fasten with four self tapping screws **FAST001** per side - 8 screws total

- This completes the roof panel -

## 2.0m H SIDE PANEL

1x required.

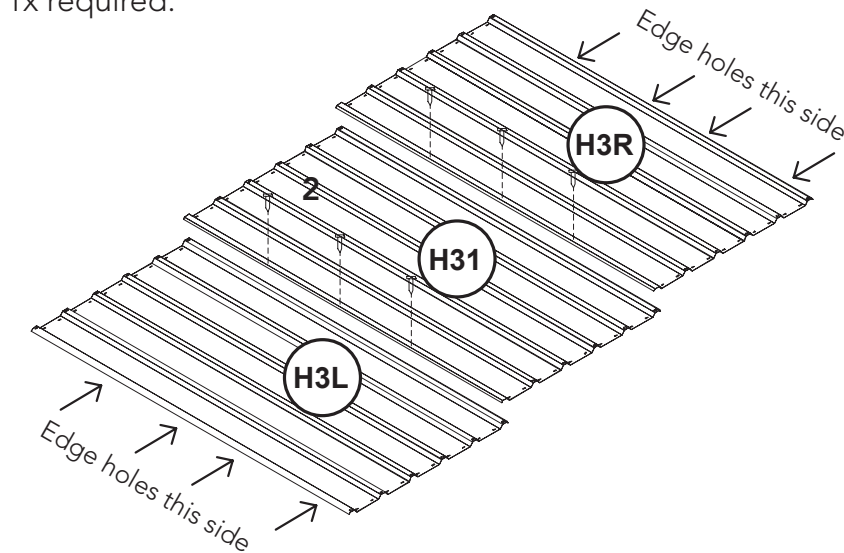

**1.** Layout and overlap sheets by one rib as shown. Orientate outside sheets as pictured.

**2.** Use 3x 3/8" self tapping screws FAST001 per overlap, through the pre punched holes.

**3.** Attach the top and bottom channels using the SNAP-TiTE method.

Make sure you have the shorter, 0.6" side of the channel to the exterior of the sheeting

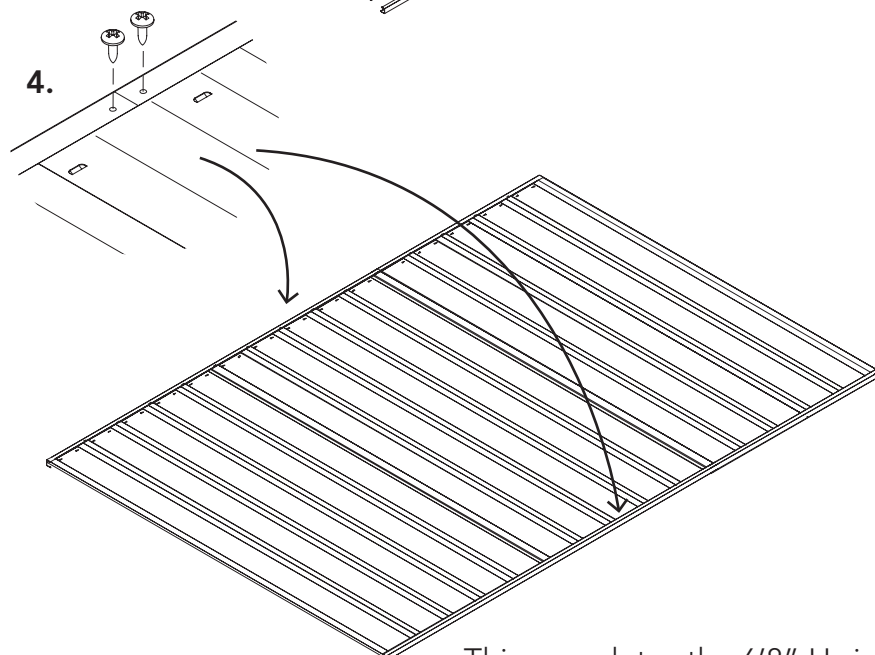
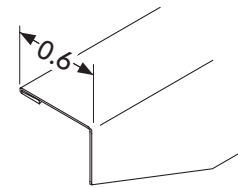
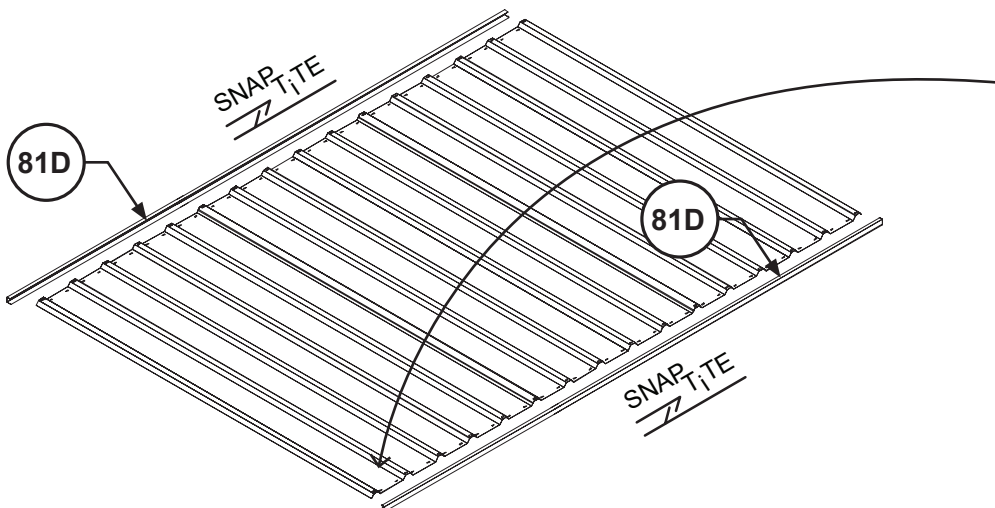

**4.** Now both channels are attached, fasten their L&R pieces to the CSJ with a 3/8" self tapping screw FAST001 in each top hole.

- This completes the 6'8" H side panel -

## 5'11" H SIDE PANEL

1x required.

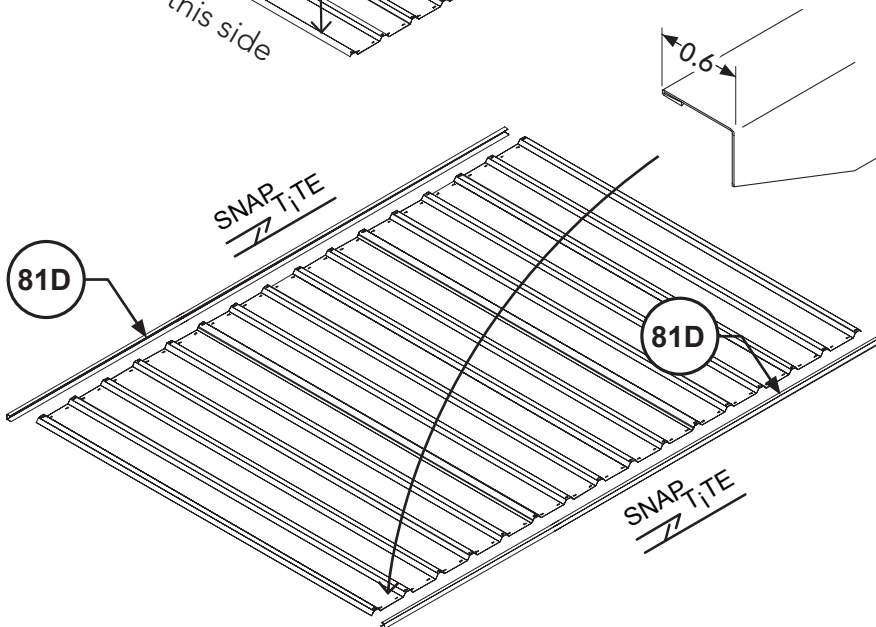
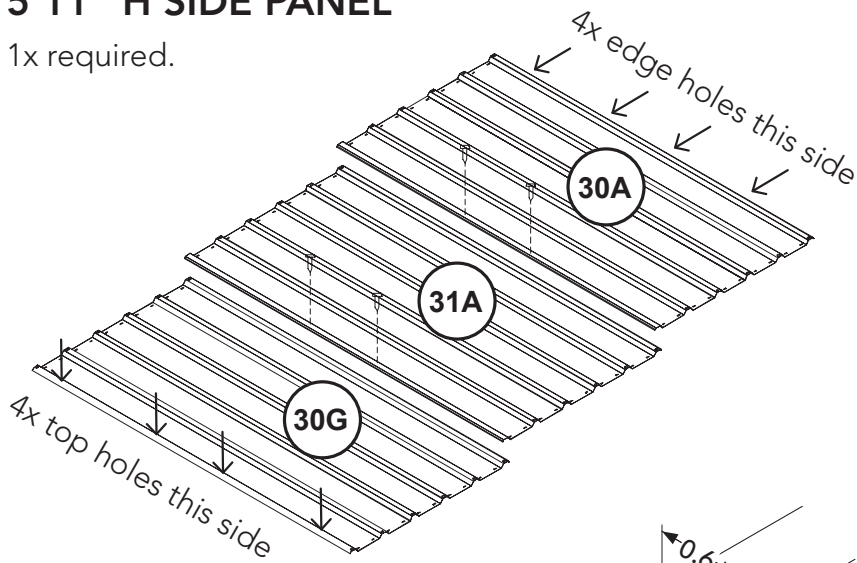

**1.** Layout and overlap sheets by one rib as shown. Orientate outer sheets with holes to the outside as pictured.

**2.** Use 2x 3/8" self tapping screws FAST001 per overlap, through the pre punched holes.

**3.** Attach the top and bottom channels using the SNAP-TITE method.

Make sure you have the shorter, 0.6" side of the channel to the exterior of the sheeting

**4.** Now both channels are attached, fasten their L&R pieces to the CSJ with a 3/8" self tapping screw FAST001 in each top hole.

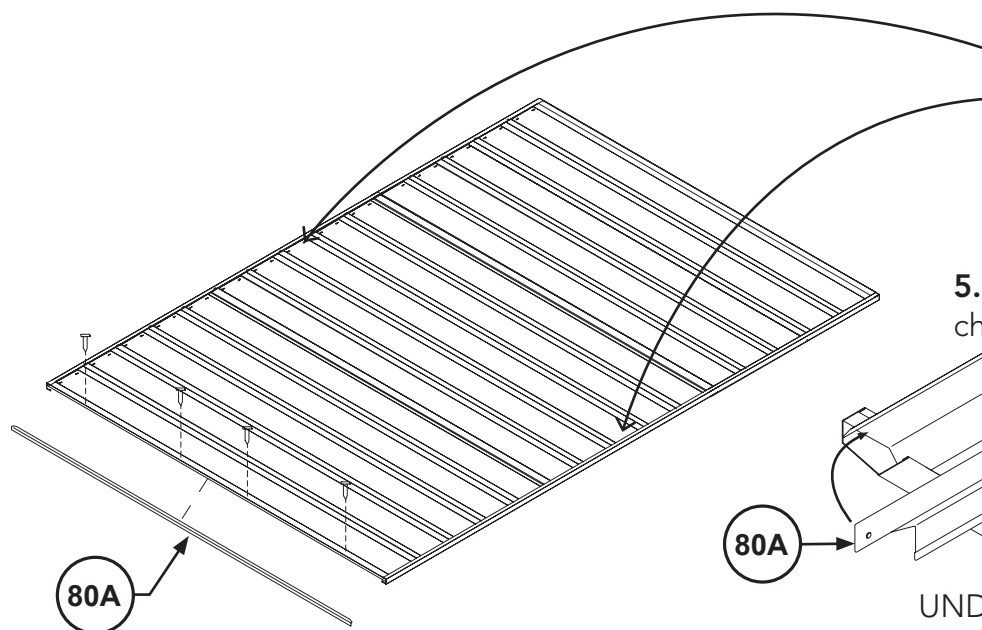
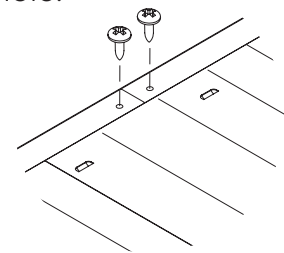

**5.** Insert the 80A into end channels and sheet rib and fix.

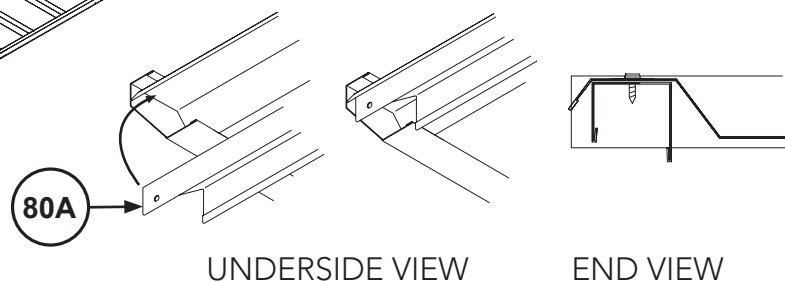

- This completes the 5'11" H side panel -

## DOOR PANEL ASSEMBLY

1x required.

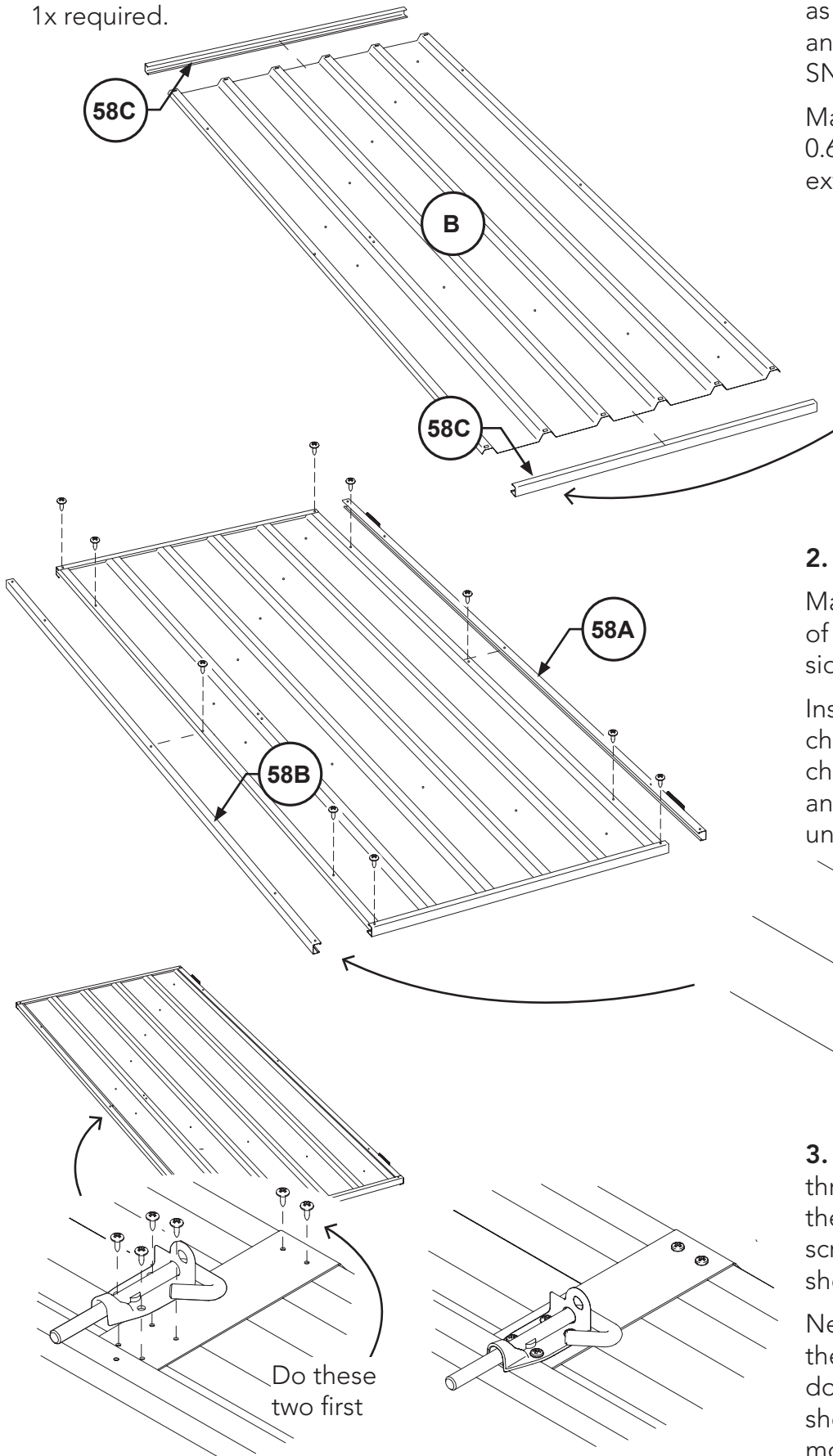

**1.** Position the **DoorB** sheet as shown and attach the top and bottom channels using the SNAP-TiTE method.

Make sure you have the shorter, 0.6" side of the channel to the exterior side of the sheeting

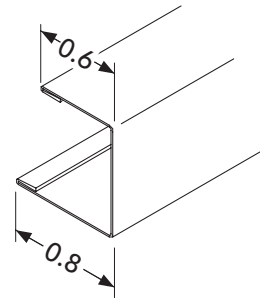

**2.** Insert the two vertical channels  
Make sure the *longer*, 0.8" side of the channel to the exterior side of the sheet.

Insert the 0.8" side of the channel in the top and bottom channels, on top of the sheet and let the bottom side go under.

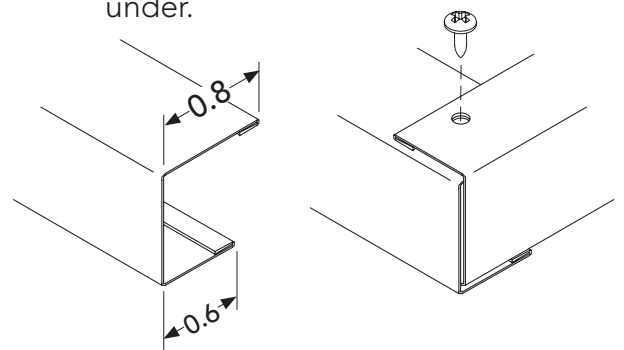

**3.** Attach the **12A** door plate through the pair of holes in the sheet with two self tapping screws **FAST001** at the location shown.

Next align the padbolt with the four remaining holes in the door plate and fasten into the sheeting underneath with four more screws.

**DOOR PANEL ASSEMBLY**  
CONTINUED

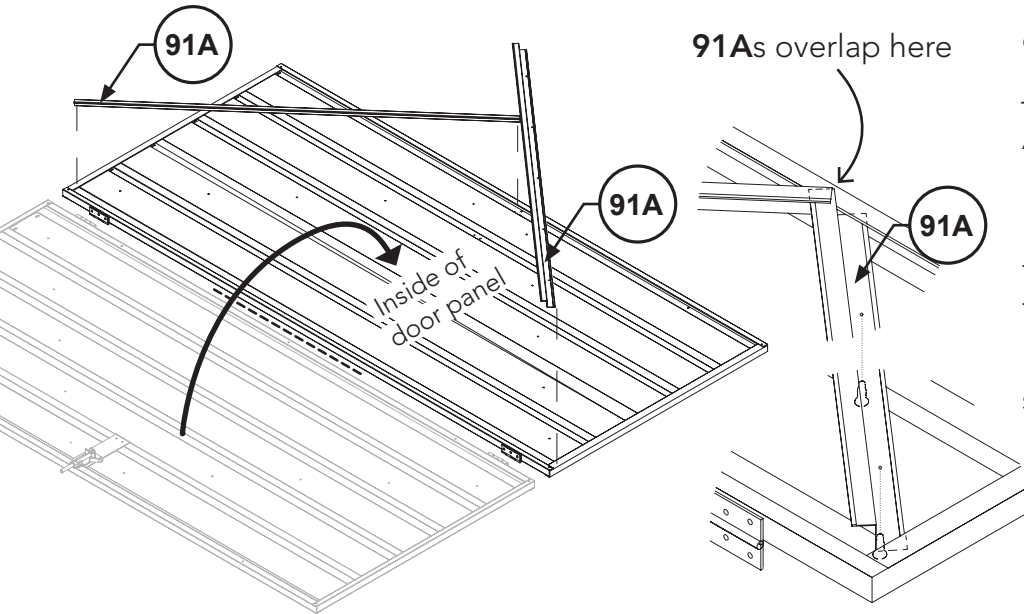

8. Turn the door over as shown.

9. Now we'll fit the two **91A** jamb door braces.

Align the holes in the brace with holes in the door.

Make sure to tuck both ends of the brace into the channels that frame the door.

Fasten from beneath with five self tapping screws FAST001.

- This completes the door panel -



## FRONT PANEL

1x required.

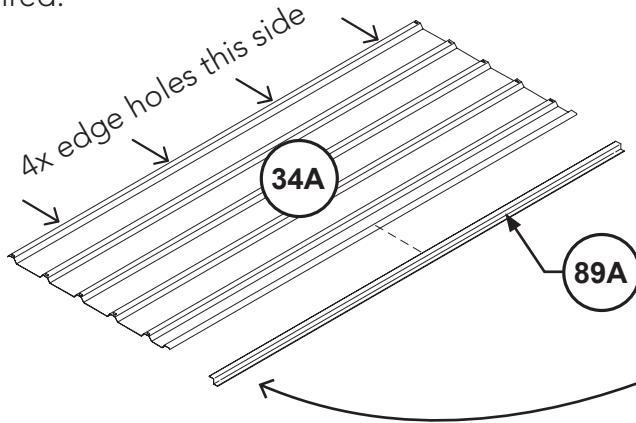

1. Orientate the 34A sheet as shown and place the 89A jamb on top.

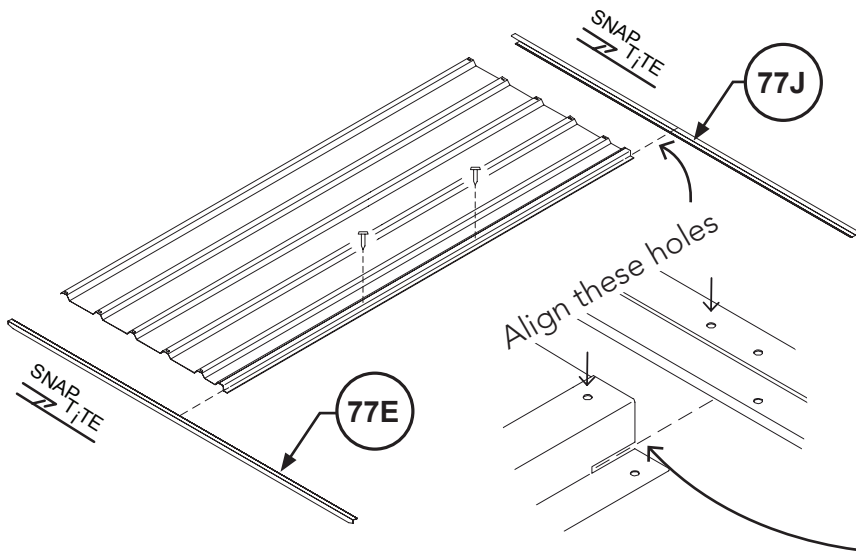

2. Use 2x 3/8" self tapping screws **FAST001** per overlap, through the pre punched holes in the parts. Only do the two shown for now.

3. Attach the channels using the SNAP-TiTE method.

Make sure you have the shorter, 0.6" side of the channel to the exterior of the sheeting.

The channel goes over the sheet and jamb with the 0.8" side going into the jamb cutout as shown.

Fasten with a screw.

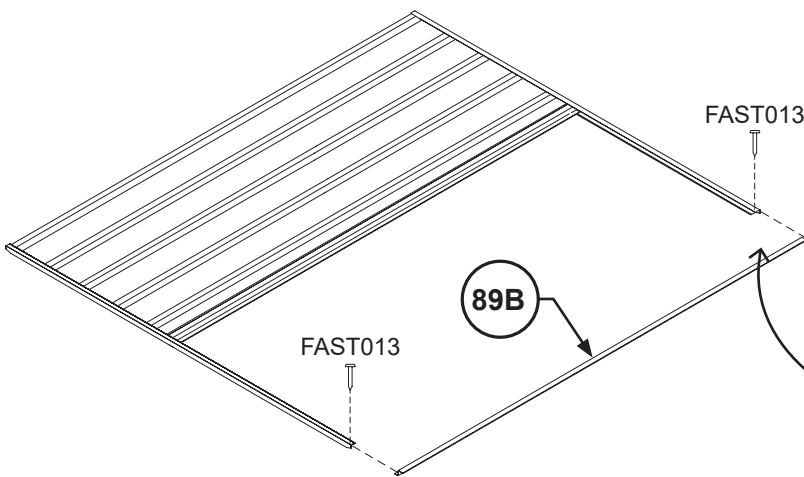
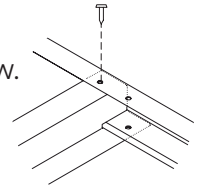

4. Insert the **89B** jamb into the top and bottom channels. Fasten with a *longer* 3/4" self tapping screw **FAST013** at each corner.

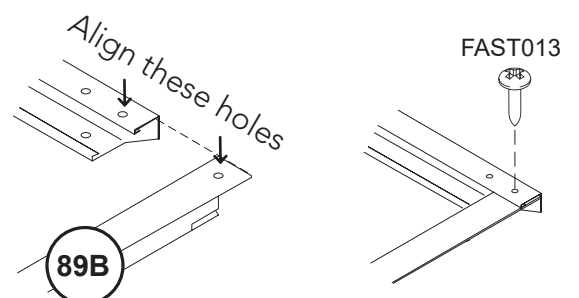

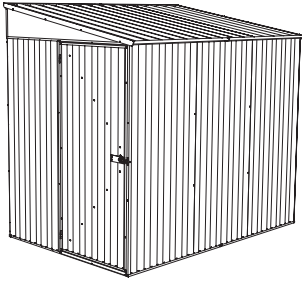
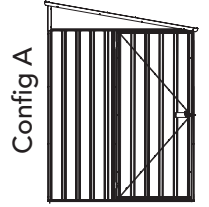

## ATTENTION!

The following pages show how to build the 'Config A' version of the shed as pictured.

If you would like to build 'Config B' go to page 20.

Config is listed on each page here

## FRONT PANEL ASSEMBLY CONTINUED

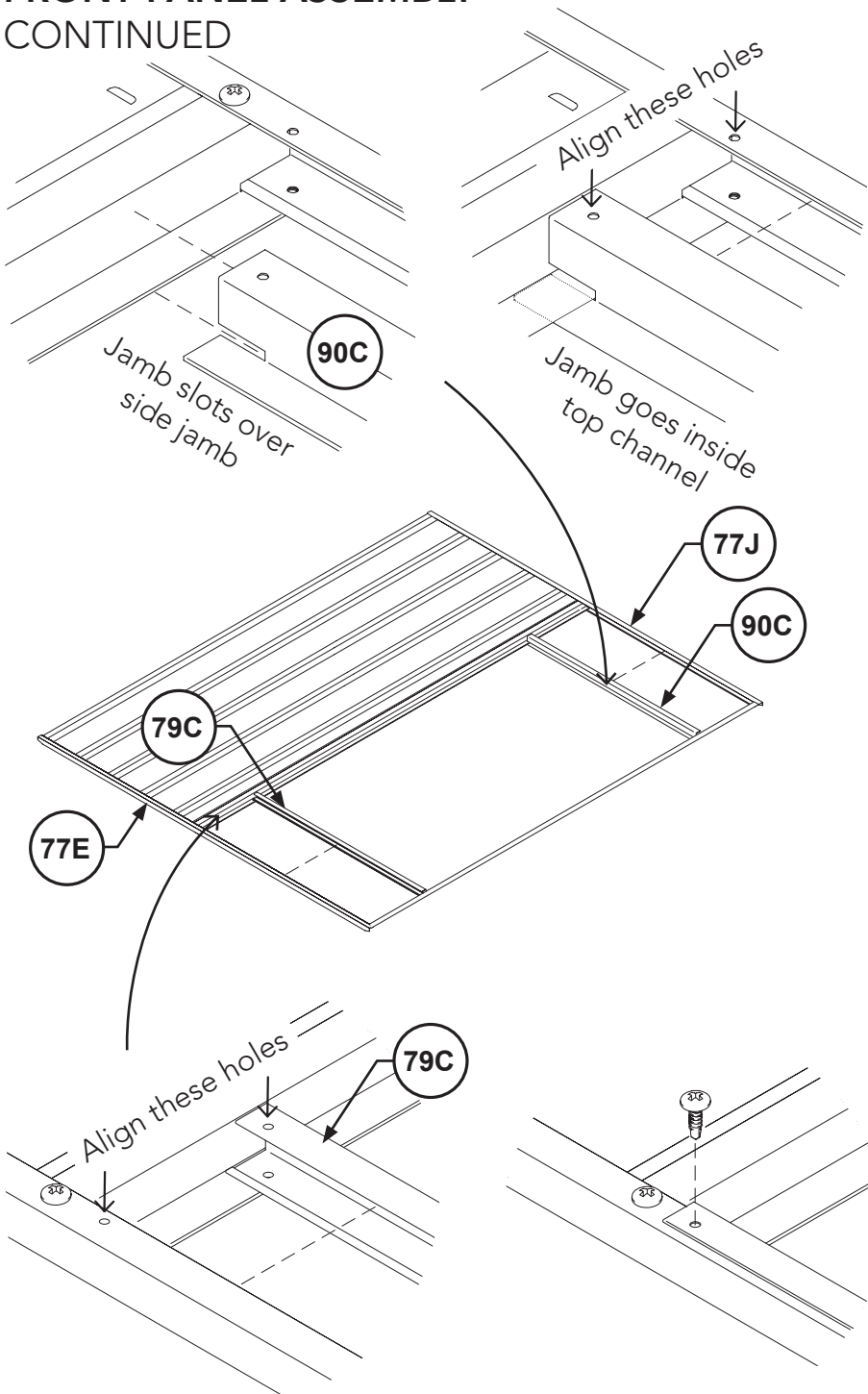

5. Next is the top-of-doorway jamb.

Orientate the top jamb **90C** so the side jamb goes into the slot and slide it up into the top channel.

Align the end hole of the jamb with the corresponding hole in the channel & fasten with a self tapping screw FAST001.

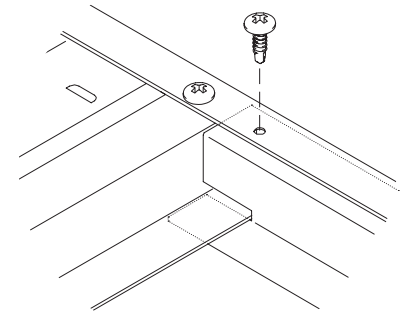

Other holes between these parts will align, fasten with more self tapping screws FAST001.

6. Now to the bottom of the doorway.

Orientate the 0.8" side of the **79C** channel so it goes into the bottom channel.

Align the end hole of the channel with the corresponding hole in & fasten with a self tapping screw FAST001.

Other holes between these parts will align, fasten with more screws.



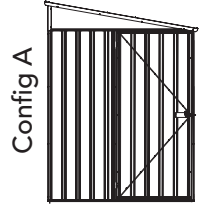

## ATTACH GABLE PANELS

### FRONT PANEL ASSEMBLY CONTINUED

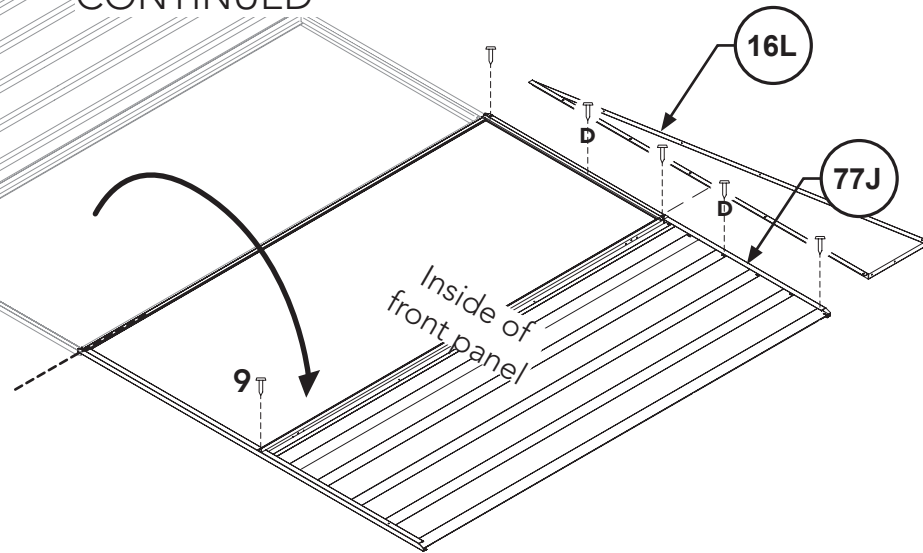

- This completes the front panel -

7. Turn the front panel over.

8. Take the **16L** gable panel and align the hole pattern with the interior side of the **77J** channel.

Fasten with three self tapping screws **FAST001** that align with existing holes in the channel

The two 'D' screws don't have channel holes, but fix through as well.

9. Fasten the vertical jambs to the top and bottom channels with a **FAST001** screw in each corner of the doorway.

### REAR PANEL ASSEMBLY CONTINUED

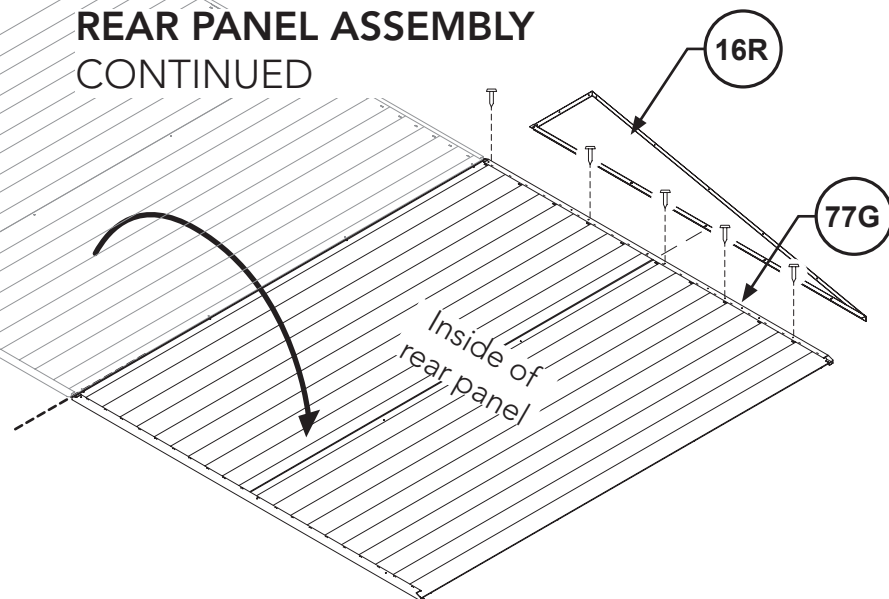

- This completes the rear panel -

4. Turn the rear panel over.

5. Take the **16R** gable panel and align the hole pattern with the interior side of the **77G** channel.

Fasten with five self tapping screws **FAST001** that align with existing holes in the channel.



## ATTACH DOOR TO FRONT PANEL

**1.** Use the supplied 1/8" drill bit **DRILL** and go through these existing jamb holes and into the sheet behind.

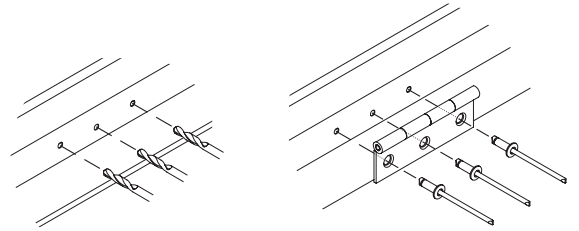
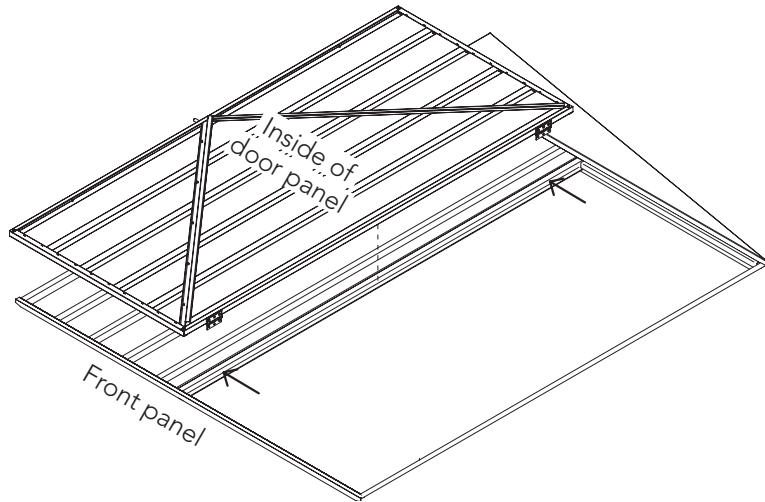

**2.** Lay the door in the open position so the hinges dangle over their matching holes.

Align and use a pop riveter and three FAST009 rivets per hinge - six rivets total.

- This completes the door panel installation -

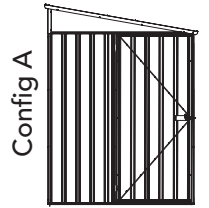

## PANEL CONSTRUCTION

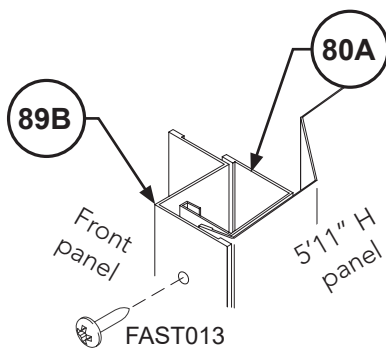
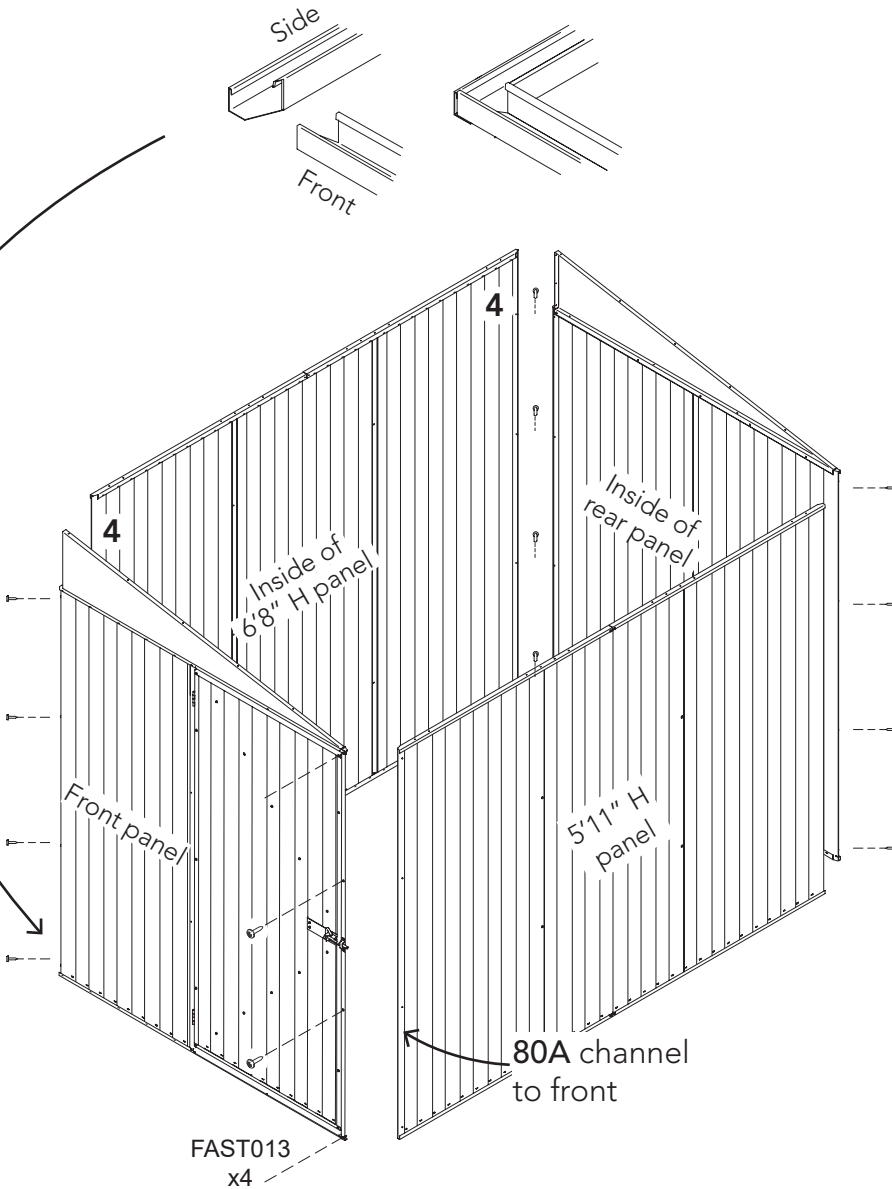

SECTION VIEW

Side wall sheet is tucked in behind **89B** jamb.

**1.** Start with the front panel, open the door to help stand it up.

**2.** Attach the 5'11" H side panel next.

Sit the side wall channel inside the end wall channels as shown below.

Align the holes in the **80A** channel with those in the front panel **89B** jamb

Fasten with four longer 3/4" self tapping screw **FAST013**.

**3.** Bring in the rear wall next, align the four edge holes in both sheets and fasten with 3/8" self tapping screws **FAST001**.

**4.** Bring in the 6'8" H side panel next. Make sure the panel is the right way up so the edge holes align with the end panels.

If required take tinsnips and make a 3/8" relief cut where the end wall top channel align with the sheeting. This will allow the panels to sit neatly. This will be covered.

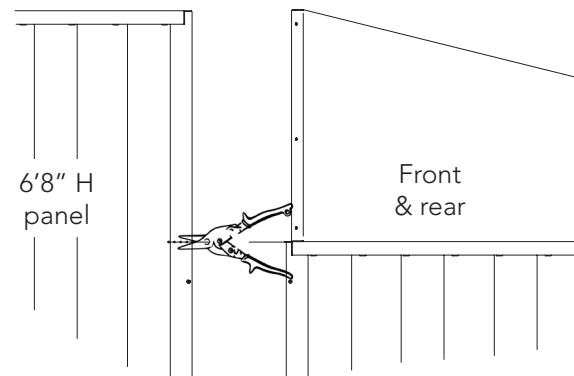

Fasten with four 3/8" self tapping screws **FAST001** per corner.

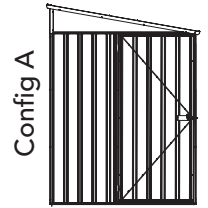

## FINAL CONSTRUCTION

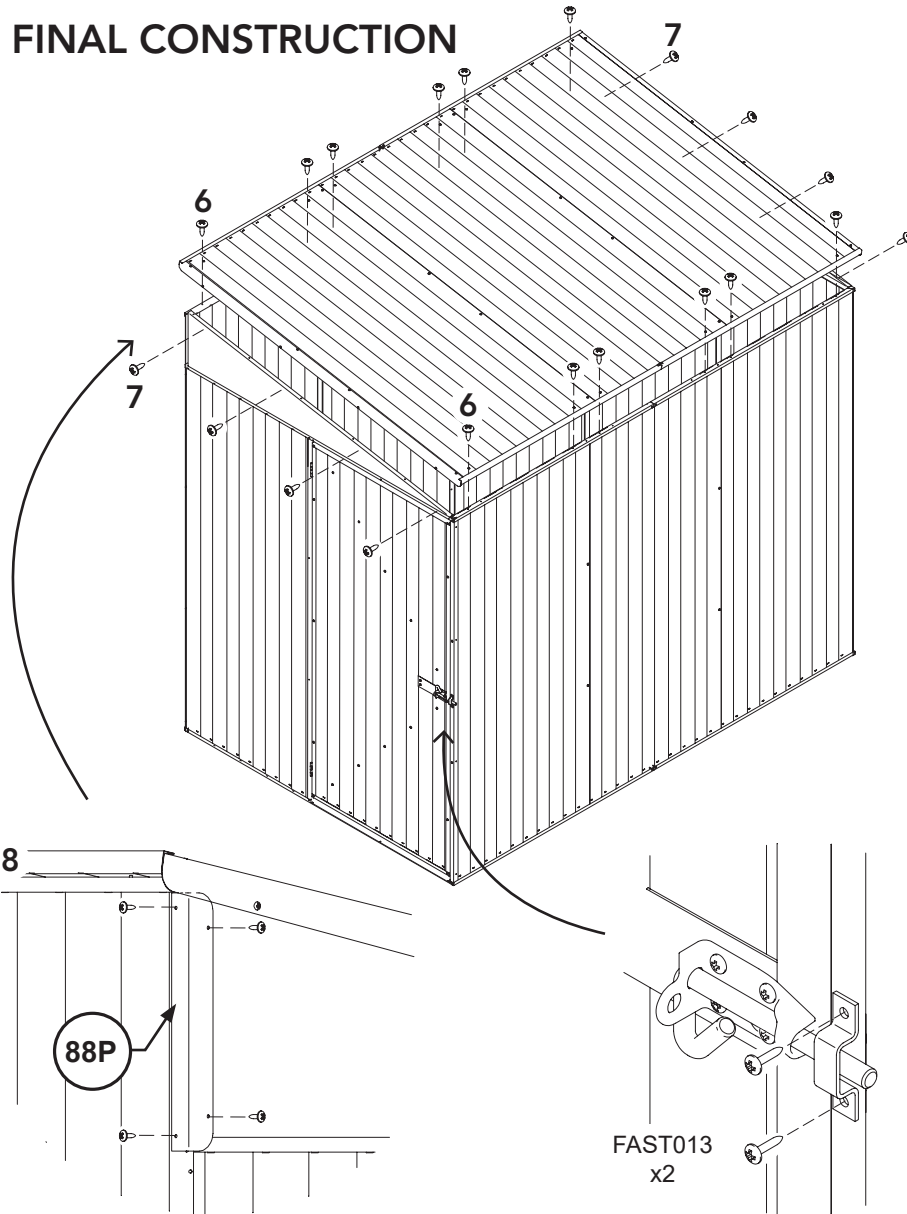

**5.** Square up the shed walls. Make sure they're straight and check opposite corner-to-corner dimensions are equal.

**6.** Safely place roof panel on top and align roof sheet holes with channels of the side walls and fix with a 3/8" self tapping screws **FAST001** at each hole. Check roof lips sit nicely at front and rear walls first.

**7.** Using the four existing holes in the lips as a template, drill holes into the gable panels and then fix with 3/8" self tapping screws **FAST001**

**8.** Cover the top corner gap with the **88P** lips as shown, tuck under roof lip. Fasten each with four 3/8" self tapping screws **FAST001**, predrill gable first.

**9.** Take the hasp, place it on the edge of the 89B jamb of the front panel and centre it over the padbolt shaft.

Use two longer self tapping screws **FAST013** to secure it.

## ANCHORING

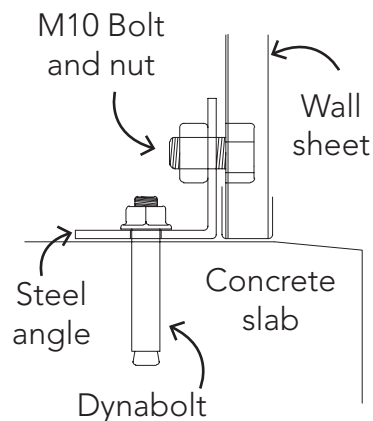
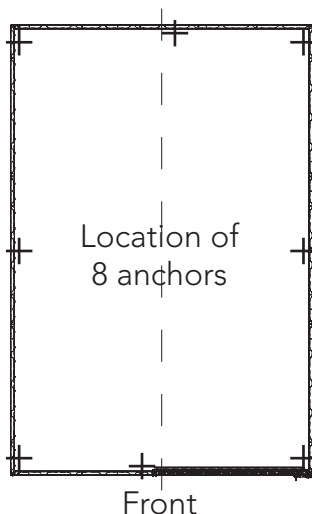

Each anchor consists on one nut, bolt, dynabolt and steel angle.

**1.** Drill a 10mm hole into the wall sheet.

**2.** Drill a 10mm hole into the concrete slab.

**3.** Position the steel angle.

**4.** Place the dynabolt into the concrete hole & tighten.

**5.** Secure the steel angle to the wall sheet using the nut & bolt.

**6.** Repeat for each anchor location

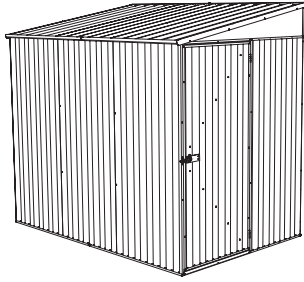

The following pages show how to build the 'Config B' version of the shed as pictured.

If you would like to build 'Config A' go back to page 15.

Config is listed on each page here

**FRONT PANEL ASSEMBLY**  
CONTINUED

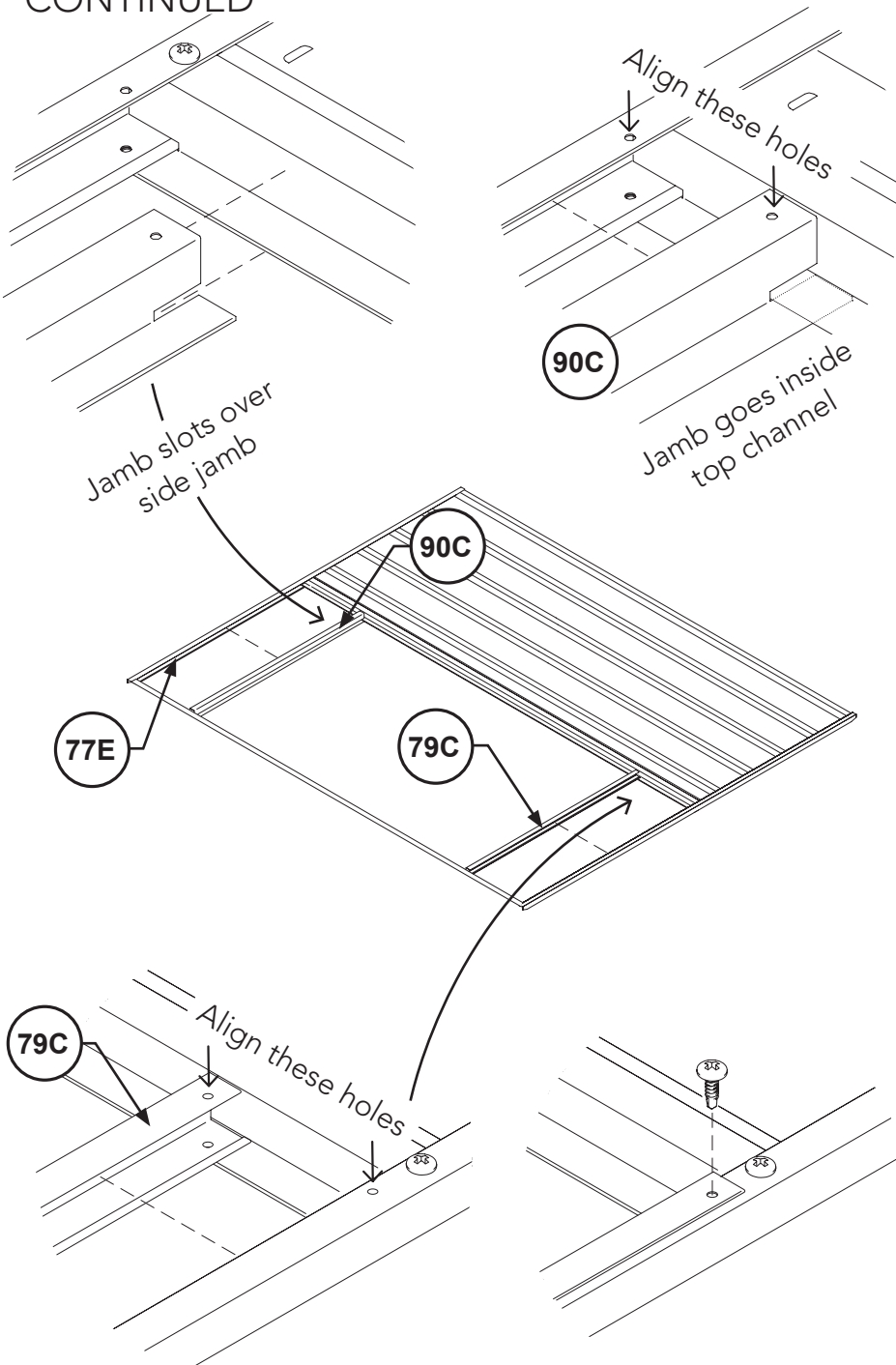

**NOTE:** Orientate panel so door opening is on the left as pictured.

**5.** Orientate the top of doorway jamb **90C** so the side jamb goes into the slot and slide it up into the top channel.

Align the end hole of the jamb with the corresponding hole in the channel & fasten with a self tapping screw FAST001.

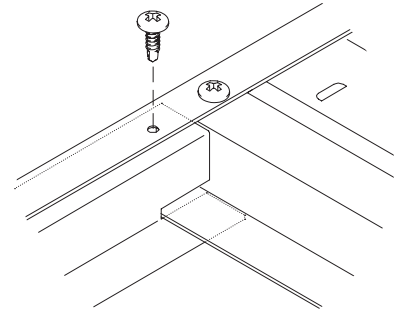

Other holes between these parts will align, fasten with more self tapping screws FAST001.

**6.** Now to the bottom of the doorway.

Orientate the 0.8" side of the **70C** channel so it goes into the bottom channel.

Align the end hole of the channel with the corresponding hole in & fasten with a self tapping screw FAST001.

Other holes between these parts will align, fasten with more screws.



## ATTACH GABLE PANELS

### FRONT PANEL ASSEMBLY CONTINUED

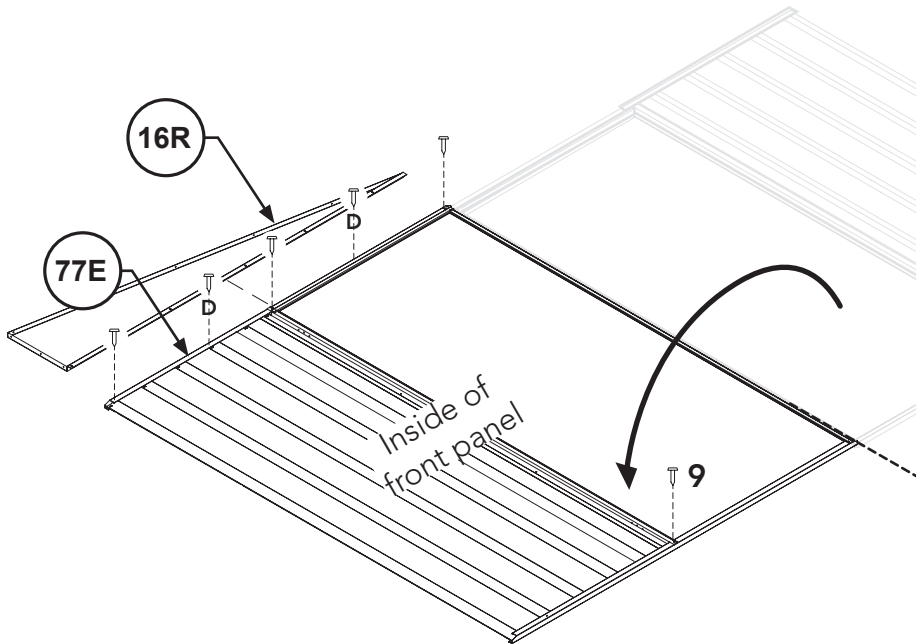

- This completes the front panel -

7. Turn the front panel over.

8. Take the **16R** gable panel and align the hole pattern with the interior side of the **77E** channel.

Fasten with three self tapping screws **FAST001** that align with existing holes in the channel

The two '**D**' screws don't have channel holes, but fix through as well.

9. Fasten the vertical jambs to the top and bottom channels with a **FAST001** screw in each corner of the doorway.

### REAR PANEL ASSEMBLY CONTINUED

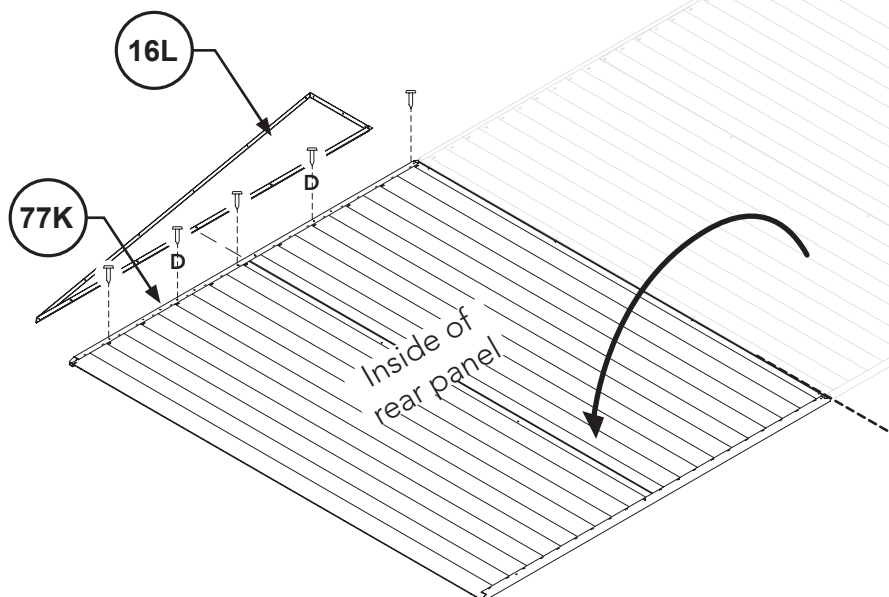

- This completes the rear panel -

4. Turn the rear panel over.

5. Take the **16L** gable panel and align the hole pattern with the interior side of the **77K** channel.

Fasten with three self tapping screws **FAST001** that align with existing holes in the channel

The two '**D**' screws don't have channel holes, but fix through as well.



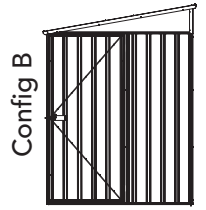

## ATTACH DOOR TO FRONT PANEL

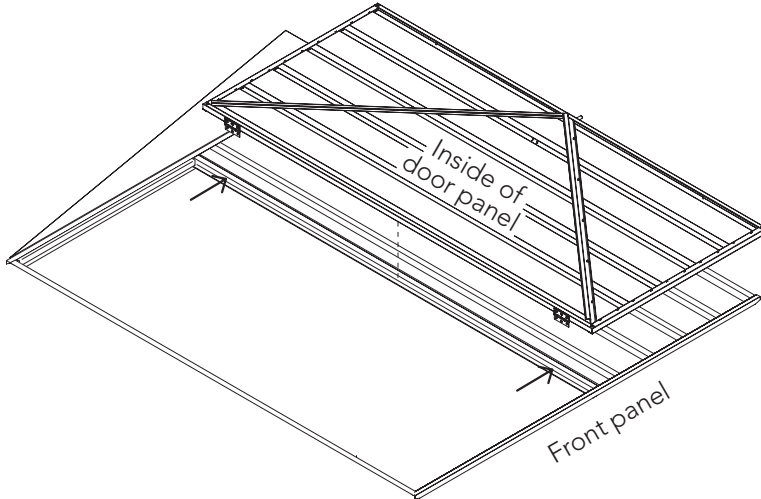

1. Use the supplied 1/8" drill bit **DRILL** and go through these existing jamb holes and into the sheet behind.

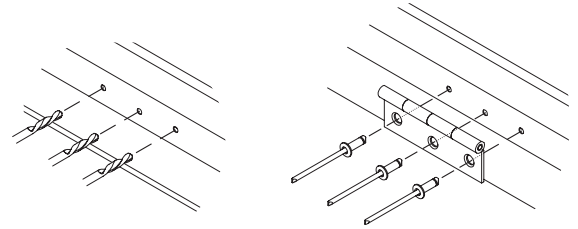

2. Lay the door in the open position so the hinges dangle over their matching holes.

Align and use a pop riveter and three FAST009 rivets per hinge - six rivets total.

- This completes the door panel installation -



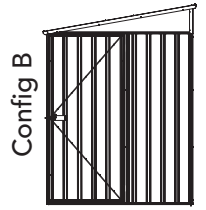

## PANEL CONSTRUCTION

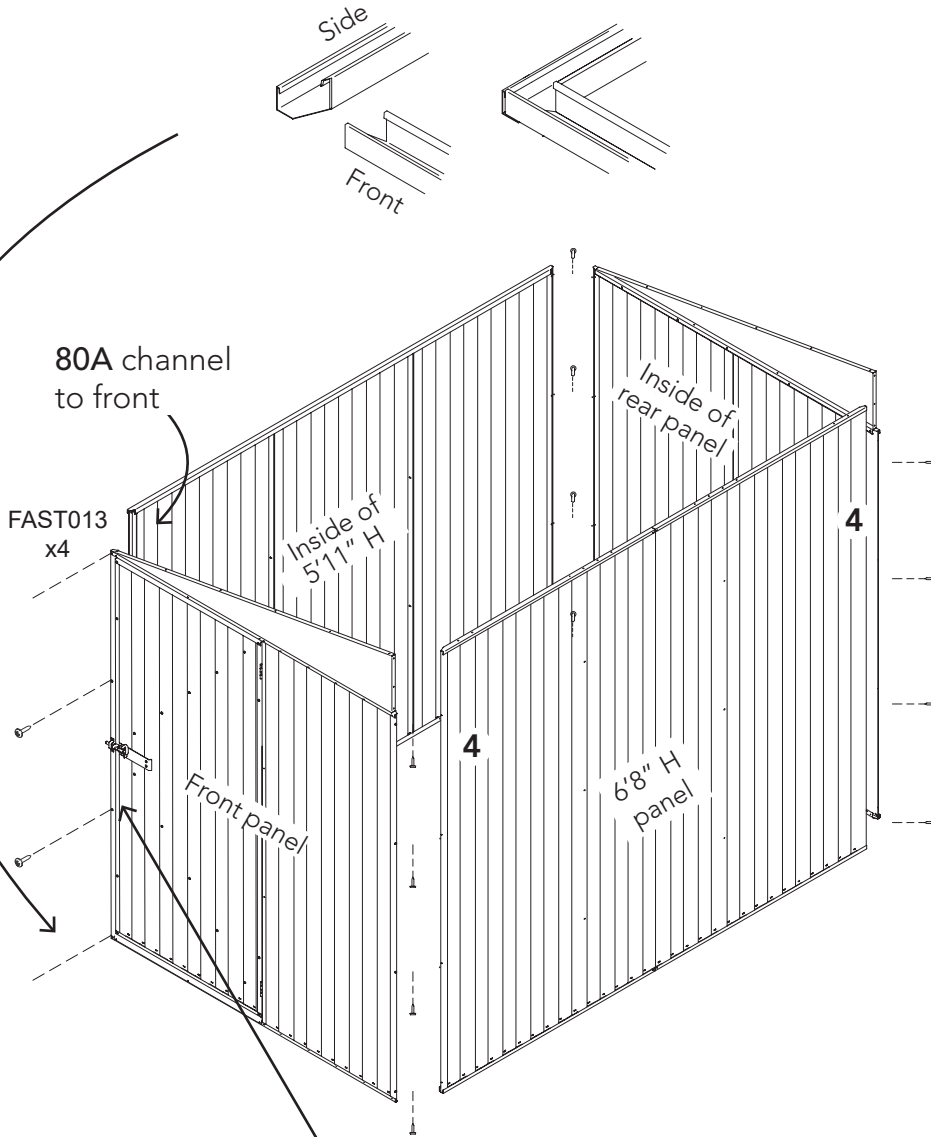

Side wall sheet is tucked in behind 89B jamb.

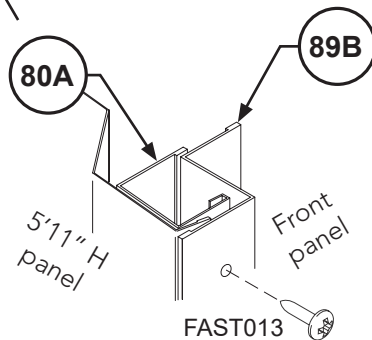

SECTION VIEW

1. Start with the front panel, open the door to help stand it up.

2. Attach the 5'11" H side panel next.

Sit the side wall channel inside the end wall channels as shown below.

Align the holes in the 80A channel with those in the front panel 89B jamb

Fasten with four longer 3/4" self tapping screw FAST013.

3. Bring in the rear wall next, align the four edge holes in both sheets and fasten with 3/8" self tapping screws FAST001.

4. Bring in the 6'8" H side panel next. Make sure the panel is the right way up so the edge holes align with the end panels.

If required take tinsnips and make a 3/8" relief cut where the end wall top channel align with the sheeting. This will allow the panels to sit neatly. This will be covered.

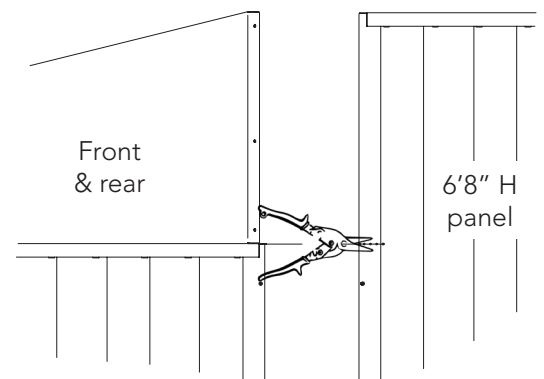

Fasten with four 3/8" self tapping screws FAST001 per corner.



## FINAL CONSTRUCTION

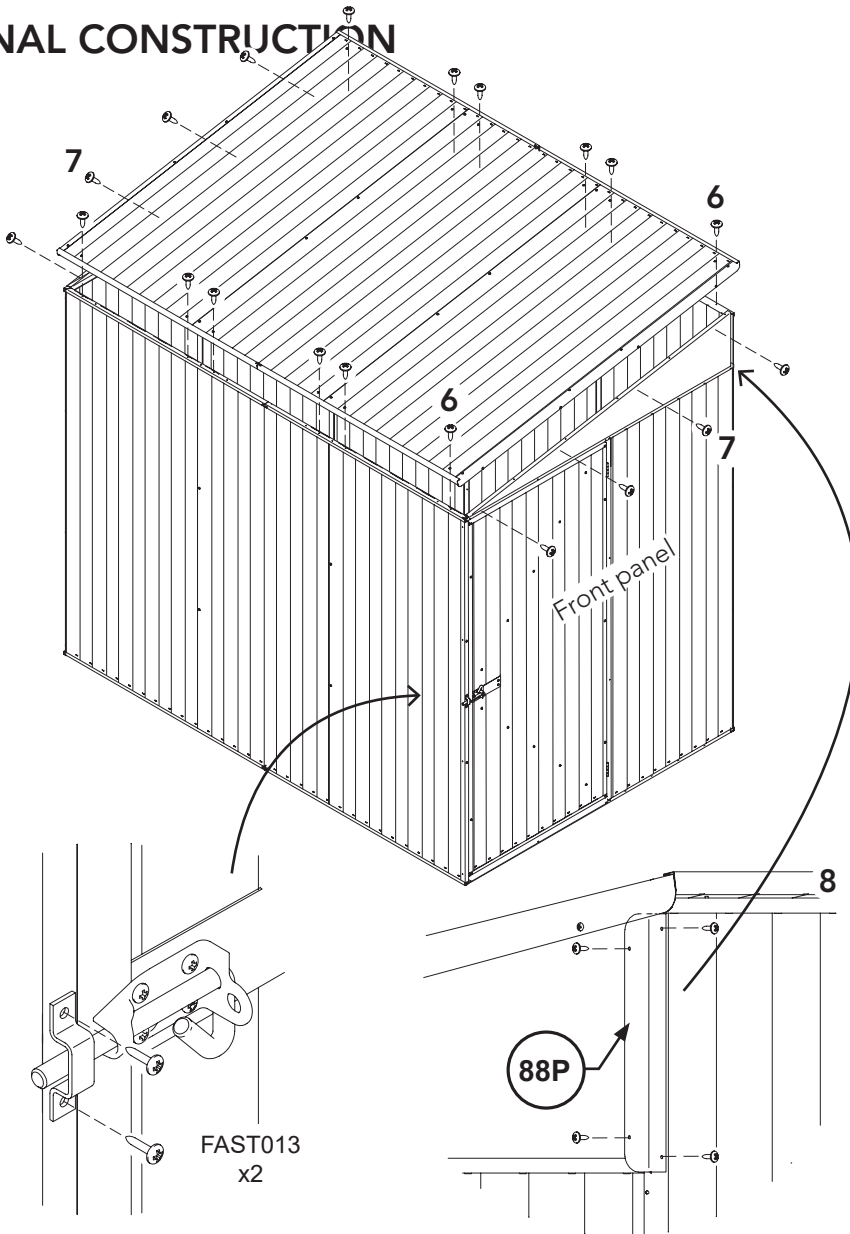

**5.** Square up the shed walls. Make sure they're straight and check opposite corner-to-corner dimensions are equal.

**6.** Safely place roof panel on top and align roof sheet holes with channels of the side walls and fix with a 3/8" self tapping screws **FAST001** at each hole. Check roof lips sit nicely at front and rear walls first.

**7.** Using the four existing holes in the lips as a template, drill holes into the gable panels and then fix with 3/8" self tapping screws **FAST001**

**8.** Cover the top corner gap with the **88P** lips as shown, tuck under roof lip. Fasten each with four 3/8" self tapping screws **FAST001**, predrill gable first.

**9.** Take the hasp, place it on the edge of the 89B jamb of the front panel and centre it over the padbolt shaft.

Use two longer self tapping screws **FAST013** to secure it.

## ANCHORING

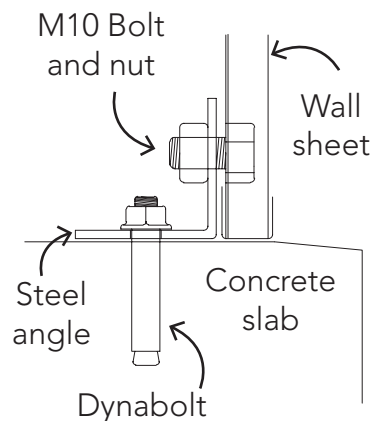
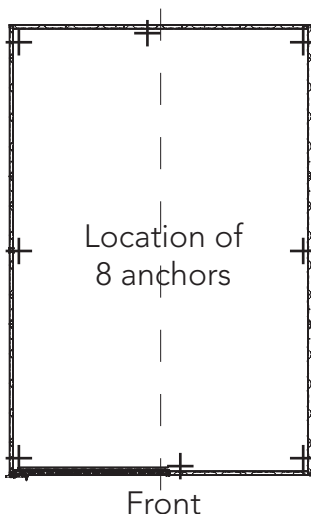

Each anchor consists on one nut, bolt, dynabolt and steel angle.

**1.** Drill a 10mm hole into the wall sheet.

**2.** Drill a 10mm hole into the concrete slab.

**3.** Position the steel angle.

**4.** Place the dynabolt into the concrete hole & tighten.

**5.** Secure the steel angle to the wall sheet using the nut & bolt.

**6.** Repeat for each anchor location

---

## Absco Sheds Storage Guidelines

- Absco Sheds are designed to be weatherproof for normal weather conditions. In the event of extreme weather conditions such as heavy rain, combined with high wind gusts, the ridge capping, sheeting joints, screw fixings etc., may exhibit minor deformations which may allow some water entry. These areas should be checked regularly to ensure that maximum strength and protection is maintained.
- Other weather conditions such as extreme heat and extreme cold, moist or dry air can influence the effects of concrete floor moisture and/or condensation on the underside of the roof sheets.
- Absco Sheds and storage units are primarily used for storage of garden equipment such as lawnmowers, wheelbarrows, garden tools etc. Storage items that might be adversely affected by any of the above conditions may require additional protection such as being sealed or covered by plastic sheets and/or stacked above the concrete floor on timber slats.
- Waterproof sealants may be used to offer further protection where required around joins and screw fixings, as can rubber door seals and other products which are available from most hardware outlets.
- Placement of waterproof sealants (silicone) between the base of the shed and concrete slab is not recommended, as this process can have a reverse effect, preventing excess water from escaping, resulting with water accumulating and being trapped inside the shed.
- Absco accepts no responsibility for water entry, floor moisture, condensation or the condition of the Contents inside your Absco steel building arising from any of the pre-mentioned weather conditions.

## EXPORT PRODUCT WARRANTY AGAINST DEFECTS

Congratulations on your purchase of an ABSCO SHED

ABSCO SHEDS, including garden sheds, garden beds, aviaries, storage units, garages, awnings and carports are made using high quality Australian made steel.

We are pleased to advise we warrant that the steel coating will not rust, crack, flake peel or blister for 12 years from date of purchase.

This warranty does not apply to surface deterioration of panels caused by 'Swarf' (Tiny particles of steel debris left from cutting, grinding or drilling operations) that has not been removed after building construction, or as a result of contact with damp soil, chemicals, fertilisers or other corrosive substances.

This warranty covers any Absco product used for normal domestic use and installed in accordance with the installation instructions.

This warranty does NOT cover Damage caused by storms, wind, rain, snow or poor foundations.

This warranty does NOT cover ABSCO products installed in severe coastal, industrial or other highly corrosive environments. The warranty does not cover fasteners (screws, nuts, bolts, rivets, hasps or sliding padbolts).

The warranty is limited to replacement and delivery of components and does not include any labour or installation costs. The benefits given by the warranty are in addition to your other rights and remedies under a law in relation to the goods or services to which the warranty relates.

In the unlikely event a warranty claim is made, it must be supported by photographic evidence and details of the defect, including component part numbers, together with proof of purchase documentation (or on-line registration of purchase) and forwarded to the address below. Upon receipt of the warranty claim, the Customer Service Manager will contact you within three business days to advise you of the assessment outcome of the claim, which may include your expenses incurred in making the claim.

THE CUSTOMER SERVICE MANAGER, ABSCO SHEDS, PO BOX 119 ACACIA RIDGE QLD AUSTRALIA 4110

PHONE: +1 (866) 788 3046

EMAIL: [warranty@absco.com.au](mailto:warranty@absco.com.au)

Issued 16 July 2019