

☎ AU: 1800 029 701
NZ: 0800 466 444

✉ admin@absco.com.au
www.absco.sheds.com.au

Opening width: 2400mm
Opening height: 2300mm
Internal wall height: 2830mm

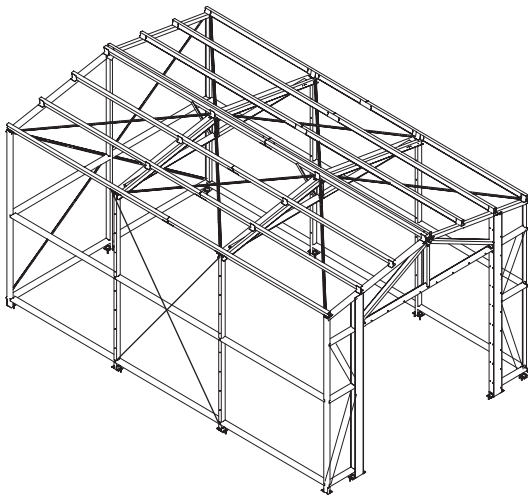
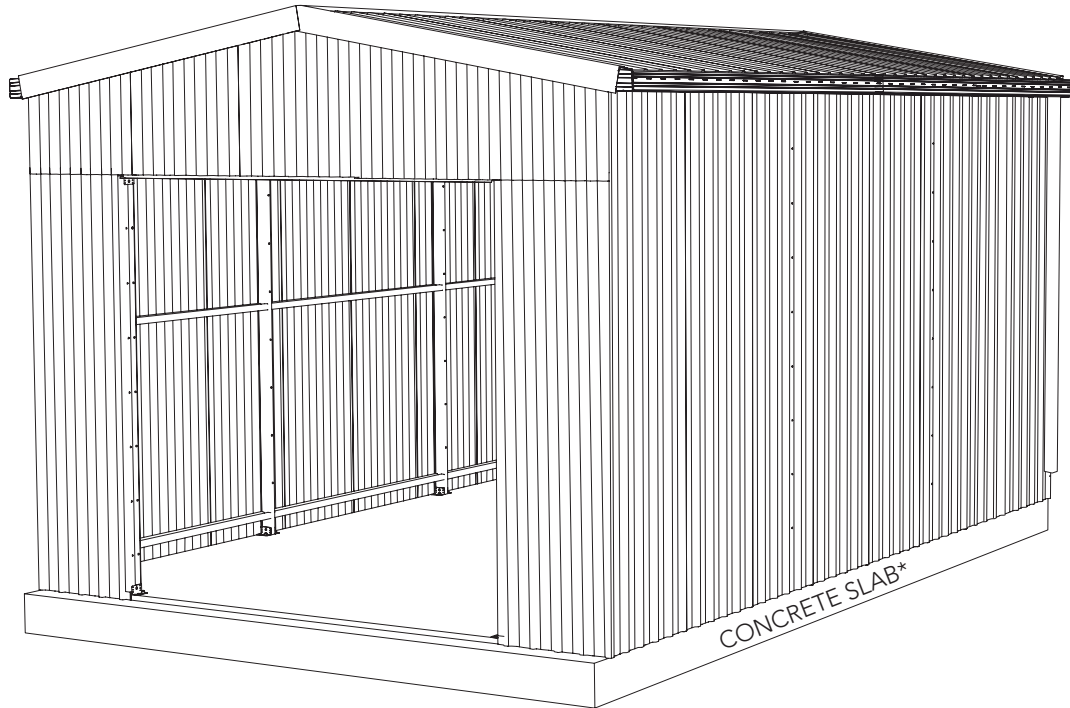

For construction in non-cyclonic areas
Wind rating: N2 as per AS4055-2021.
If you require a higher wind rating please contact
us: admin@absco.com.au or 1800 029 701

*You will need to contact a suitably qualified professional to specify concrete slab or footings for your site.

Brackets for securing the frame to either a concrete slab or footings are included in this kit. Anchors are not supplied.

Local authority approval must be obtained prior to construction. Once you have selected your site, draw a site plan and lodge your application together with a copy of the engineering plans located at the back of these instructions.



**DOWNLOAD
OUR APP FOR
ASSEMBLY
VIDEOS**



PLEASE LEAVE A REVIEW

Tell us about your experience!
Visit www.absco.sheds.com.au/review

Before Getting Started:

- Read these instructions carefully and fully so that an understanding of the steps involved in construction is obtained. Do this with constant reference to the engineering drawings provided.
- Measure and check off all the components prior to commencement. If a discrepancy is discovered, contact Absco immediately for assistance.

Part Numbers:

- All framing sections & wall and roof sheets have part numbers printed on them. The remainder of the components should be identified by their description, size and pictures provided in the component lists.

Roller Door Instructions and Engineering Certification:

- Absco Industries supplies roller doors from another Australian manufacturer. The instructions to install the door are supplied with the roller door and are not covered in this document.
- The engineering documentation that certifies the door to the appropriate wind loading is also supplied by the manufacturer.

Anchor Sets Not Supplied:

- Sleeve anchors are detailed but not supplied with this garage. They can be purchased readily from most hardware stores. Anchors required for this garage is **22 OFF 12x130 mm Sleeve Anchors**.

Self Drilling Tek Screws:

- Hex head tek screws (FAST035) are to be used unless noted otherwise.
- Hex head tek screws with neoprene washer (FAST033) are to be used for securing roof sheets to framework.
- Wafer head tek screws (FAST014) are to be used on the outside of framework to keep these surfaces as smooth as possible so that sheeting can be secured to them.
- All roof and wall sheets are pan fixed. ie: Screwed through the flat pan of the steel sheeting into the framework.

Tools Required



ELECTRIC
DRILL



LADDER



ELECTRIC DRILL WITH
HAMMER FUNCTION



MALLET



TAPE
MEASURE



POP RIVET
TOOL



16mm MASONRY
DRILL BIT



SHIFTING SPANNER /
13mm SOCKET TOOL

Tools Recommended:



SPIRIT
LEVEL



PHILLIPS HEAD
SCREW DRIVER



SILICONE



TIN
SNIPS

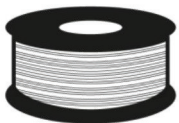

BUILDERS'
STRING



MARKER















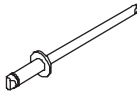



ANGLE
GRINDER

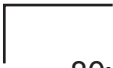





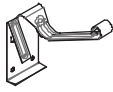
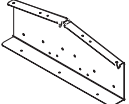
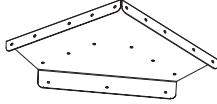





HACKSAW

Safety Notes:

- The assembly of this product requires some lifting of heavy objects. Two person lifts are required.
- Some parts have sharp edges and/or corners. The use of gloves and safety shoes is highly recommended. Pay attention to where these parts can be safely handled most safely, and plan the handling of these parts before working with them.
- Drilling sheet metal produces small metal shavings the use of safety glasses and the periodic clearing of these shavings throughout the build is recommended.
- Use the appropriate personal protective equipment for any tool used during the assembly.

























QTY	COMPONENT DESCRIPTION	PART No.	CHK	QTY	COMPONENT DESCRIPTION	PART No.	CHK
1	 PHILLIPS HD DRIVER BIT	FAST023		1	 HEX HD DRIVER BIT	FAST038	
200	 WAFER HD TEK SCREW 10-16x16mm	FAST014		1400	 HEX HD TEK SCREW 10-16x16mm	FAST035	
200	 POP RIVET 4-3	FAST009		400	 HEX HD TEK SCREW W/ NEO WASHER 10-16x16mm	FAST033	
32	 PURLIN BRACKET	BKT11		26	 MULTI-PURPOSE BRACKET	BKT17	
8	 TRIANGLE PLATES 150x150mm	ZACO190		2	 ROOF STRAPPING L=20m	FAST040	
4	 ANGLE BRACE 40x40x600mm	ZACO124B		4	 TRUSS CONNECTOR PLATE 75x75x1mm	ZACO180	
4	 SIDE MULLION 80x150x2830mm	ZACO217		12	 HEX HD TEK SCREW 14-20x45mm	FAST081	
4	 GUTTER L=3030mm	TR22		2	 DOWNPIPE 100x75mm L=2400mm	TR10	
4	 BARGE FLASHING L=3050mm	TR06		2	 RIDGE CAPPING L= 3030mm	TR08	
2	 'L' FLASHING L=3030mm	TR19		1	 ROLLER DOOR FLASHING L=3030mm	TR21	
4	 GUTTER END STOP	TR25		2	DOWNPIPE STRAP 450x20x0.35mm	TR29	
16	 GUTTER BRACKET	RWG06		2	 DOWNPIPE DROP	RWG18	
4	 APEX PLATE	ZACO194		8	 KNEE PLATE	ZACO193	
4	 JOINER PLATE 80X80X1.0	ZACO180					

SHEET PACK

QTY	COMPONENT DESCRIPTION	PART No.	CHK	QTY	COMPONENT DESCRIPTION	PART No.	CHK
16	 STEEL SHEET 2860 x 773mm	286		16	 STEEL SHEET 1900 x 773mm	190	
1	 STEEL SHEET 3185 x 773mm	318P		1	 STEEL SHEET 850 x 773mm	085P	
1	 STEEL SHEET 3125 x 773mm	312L		1	 STEEL SHEET 3125 x 773mm	312R	
1	 STEEL SHEET 2995 x 773mm	299L		1	 STEEL SHEET 2995 x 773mm	299R	
2	 STEEL SHEET 2370 x 773mm TRIMMING REQUIRED	237		2	 STEEL SHEET 1314 x 773mm TRIMMING REQUIRED	131	

ROLLER DOOR - RATED FOR N2 WIND LOADING

QTY	COMPONENT DESCRIPTION	PART No.	CHK	QTY	COMPONENT DESCRIPTION	PART No.	CHK
1	ROLLER DOOR FOR 2400W x 2300H OPENING	RD08		2	ROLLER DOOR GUIDES	-	

FRAMING SECTIONS 40x80mm - RG37601N2FP								
FRONT FRAME see page 7 for frame identification guide								
2		FRAME SECTION L = mm	C2795		2		FRAME SECTION L = 1871mm	S1871
2		FRAME SECTION L = 2750mm	C2750		2		FRAME SECTION L = 1345mm	N1345
2		FRAME SECTION L = 2400mm	C2400		6		FRAME SECTION L = 500mm	K0500
2		FRAME SECTION L = 100mm	C0100		1		FRAME SECTION L = 745mm	J0745
2		FRAME SECTION L = 950mm	R0950		2		FRAME SECTION L = 1335mm	R1335
REAR FRAME								
2		FRAME SECTION L = 3065mm	C3065		4		FRAME SECTION L = 1830mm	K1830
2		FRAME SECTION L = 2750mm	C2750		2		FRAME SECTION L = 1870mm	M1870
2		FRAME SECTION L = 100mm	C0100					
INTERNAL FRAMES								
8		FRAME SECTION L = 2750mm	C2750		8		FRAME SECTION L = 1860mm	C1860
4		FRAME SECTION L = 2300mm	C2300		4		FRAME SECTION L = 1240mm	C1240
4		FRAME SECTION L = 370mm	C0370					
PURLINS & SIDE GIRTS								
16		FRAME SECTION L = 2960mm	C2960		8		FRAME SECTION L = 200mm	C0200
4		FRAME SECTION L = 100mm	C0100		12		FRAME SECTION L = 1450mm	K1933

Frame Section Identification Guide

There are several types of frame section, each featuring a different combination of notches and/or holes. Frame sections are coded with a letter representing the type of frame section, followed by the length of the frame section in millimetres.

EG: C2960 = Straight cut both ends with overall length of 2960mm

C-TYPE - Straight cut at both ends

M-TYPE - 45mm lip notch at both ends

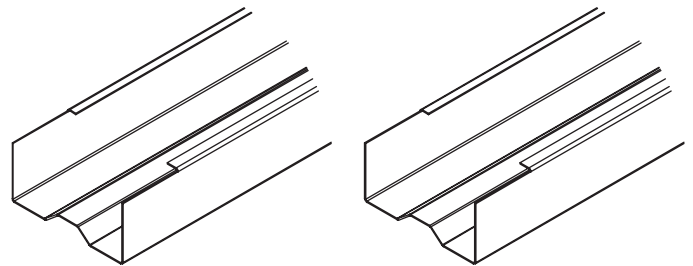
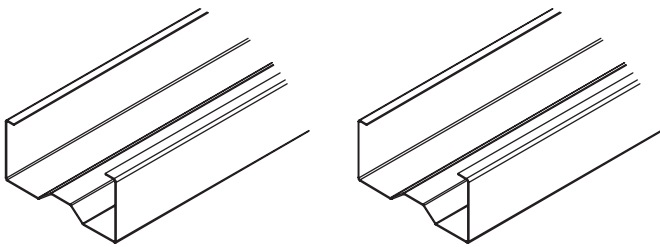

J-TYPE - Straight cut at one end: 20mm tab notch with holes at other end

N-TYPE - Straight cut at one end: 45mm lip notch/20mm tab notch with holes at other end

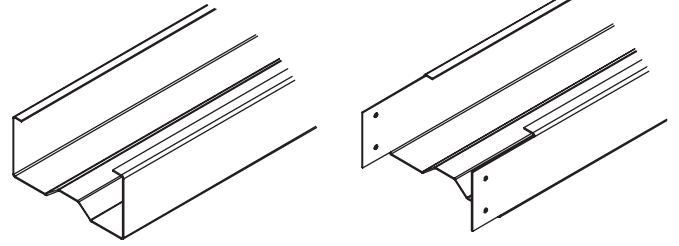
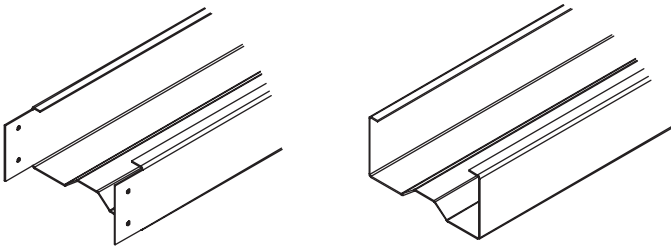

K-TYPE - 20mm tab notch with holes at both ends

P-TYPE - 45mm lip notch/20mm tab notch with holes at both ends.

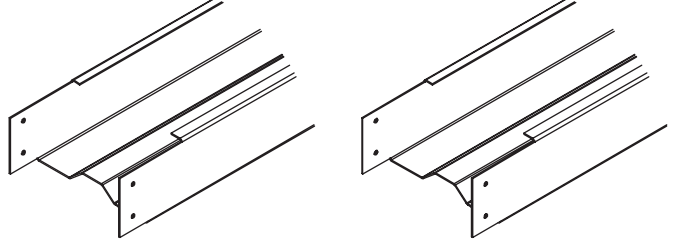
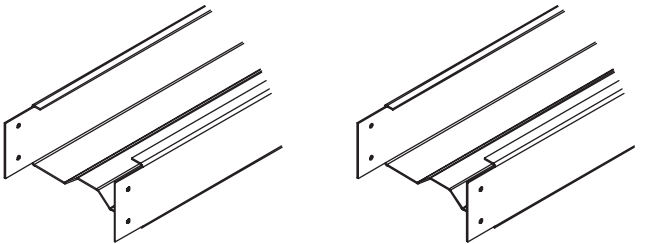

L-TYPE - Straight cut at one end: 45mm lip notch at other end.

R-TYPE - 45mm lip notch/20mm tab notch with holes at one end: 90mm lip notch at other end.

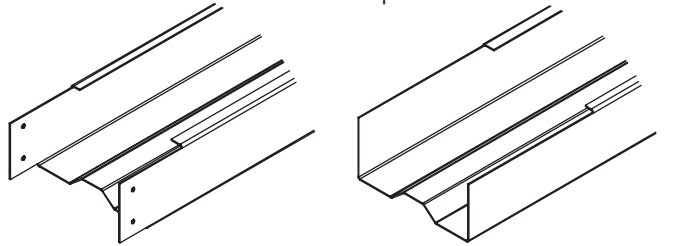
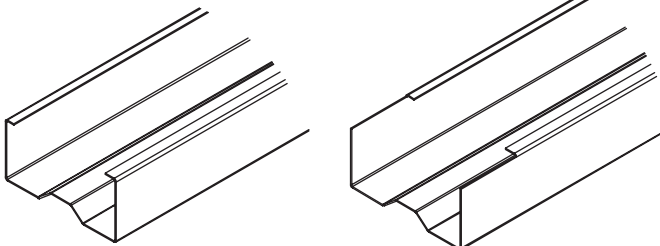

S-TYPE - Variable notching and/or holes nominated in parts checklist

COMPONENT OVERVIEW

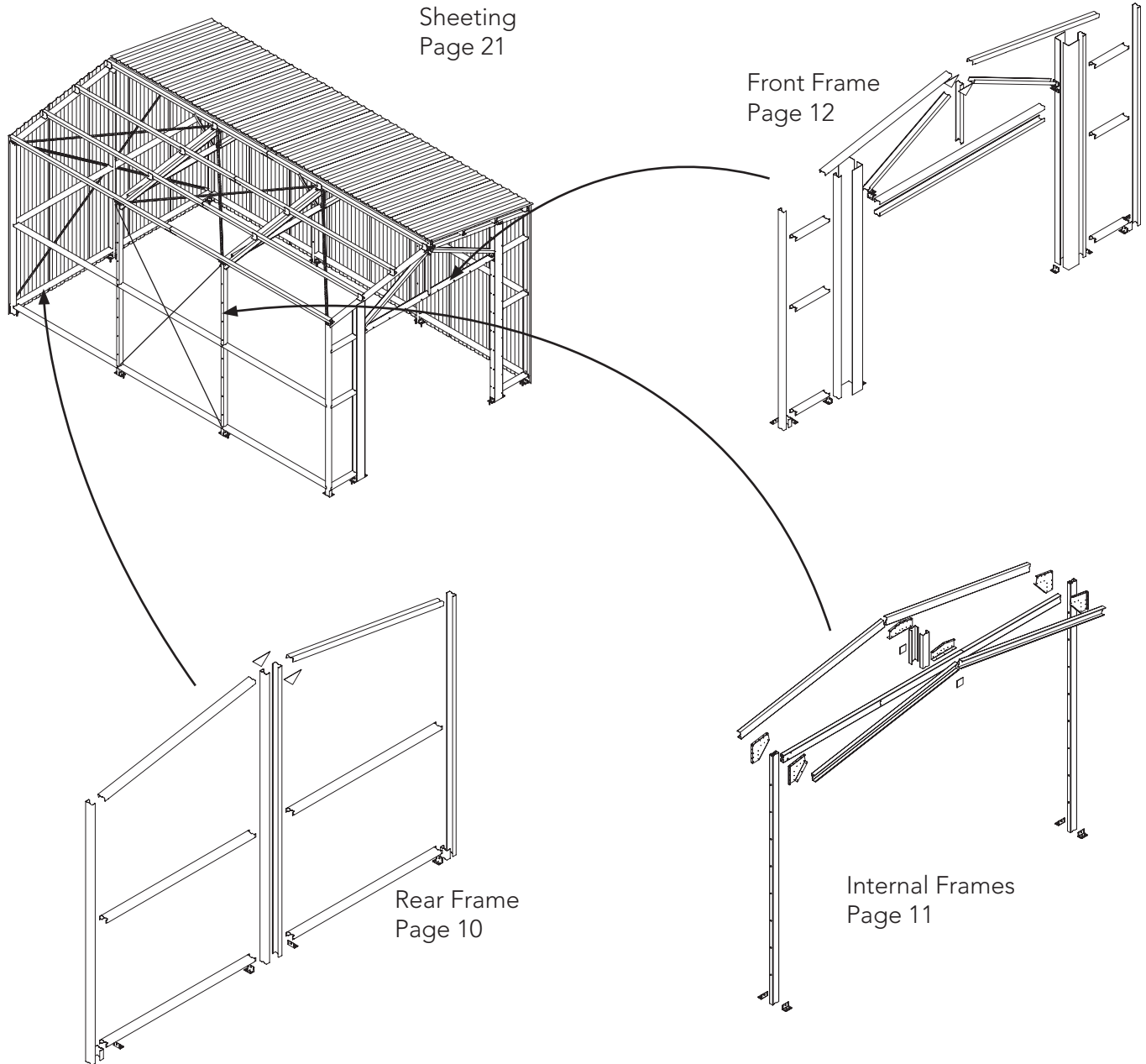

The frame is constructed from 80mm x 40mm galvanised steel channel, similar to that used in domestic steel house framing. All sections are cut to exact lengths, with channel ends pre-punched where necessary to simplify assembly.

Channel sections are secured together using 10G self drilling tek screws (supplied). Roof sheets are secured to the frame using 10G x self drilling tek screws with neoprene washers (supplied). Barge capping is secured together using 3mm pop rivets (supplied).

Guide for Connecting Frame Sections

Absco sheds' frame assemblies are supplied with 10-16x16 self drilling wafer head phillips drive tek screws

The wafer head minimises distortion to the sheet cladding once it is fitted to the frame

Ensure that driver bits used to fasten these screws is phillips drive, as similar alternatives (EG. Pozi drive) increases the risk of stripping the head of these screws.

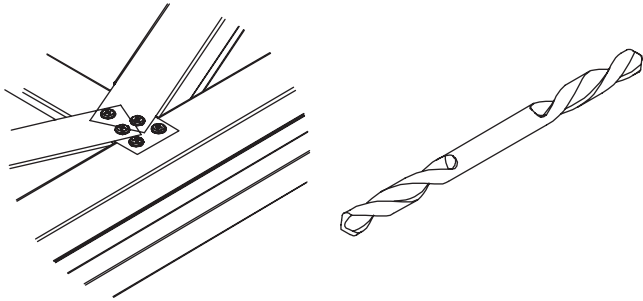

Absco sheds' frame sections are manufactured from light gauge steel, enabling for the notched ends or lengths of one frame section to be spread over the sides of another frame section, boxed frame section or H-section.

Some connections are designed to fasten more than two parts together. Connections may also not feature a defined alignment or physical stop.

For these reasons, focus on arranging all parts of a frame assembly or subassembly together (to the overall sizes and check measurements nominated) using minimal screws. This allows for easier adjustment to various connections which may be necessary to achieve the overall dimensions and check measurements that are nominated.

Fit the remaining screws once the frame assembly or subassembly is assembled as per the overall dimensions and check measurements that are nominated

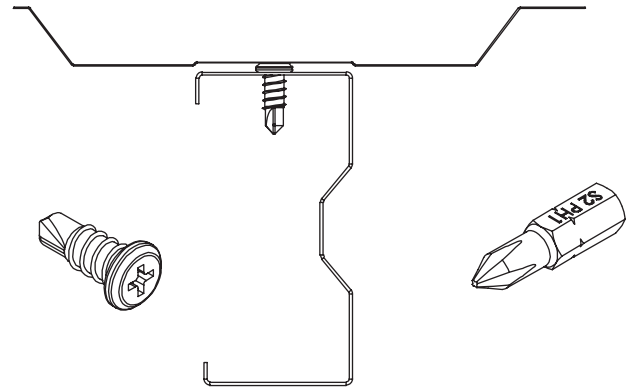

Some holes are pre-punched in Absco sheds' frame sections, however the wide range of positions that most fasteners are required for means that the remainder have to be drilled as per the connection being made

A 3mm drill bit is supplied for pre-drilling holes where self drilling screws may be more difficult to establish holes with (EG. Fitment of purlin brackets).

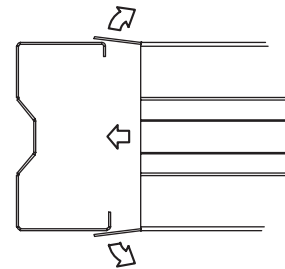

Boxing Frame Sections

Absco sheds' frame sections are designed to nest into one another to create boxed frame sections. Boxed frame sections are only required in some parts of the entire frame assembly.

Boxed frame sections are fastened together using the fast014 tek screws supplied at 300mm centres (unless otherwise stated) along the length of each boxed frame section.

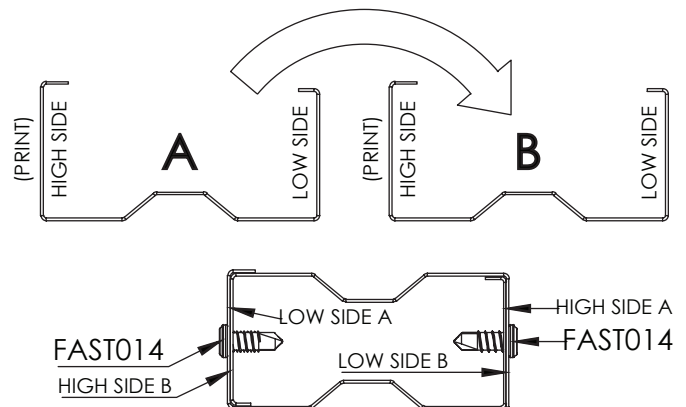

Rear Frame

- Box these frame sections together.
1 OFF: C3065 + C3065
- Lay the parts out on your slab or another level area as shown below.
- Check diagonals for squareness, then join all components together with tek screws. Make sure FAST014 are used on exterior side.
- Refer to engineering drawing for quantity of screws required at connection points.
- Double check the dimensions and draw an outline of the frame onto the ground with chalk to use as a template for the internal and front frames.
- Use C0100 box the bottom of the two C2750 as shown.
- Turn the frame over carefully & fix the other side.

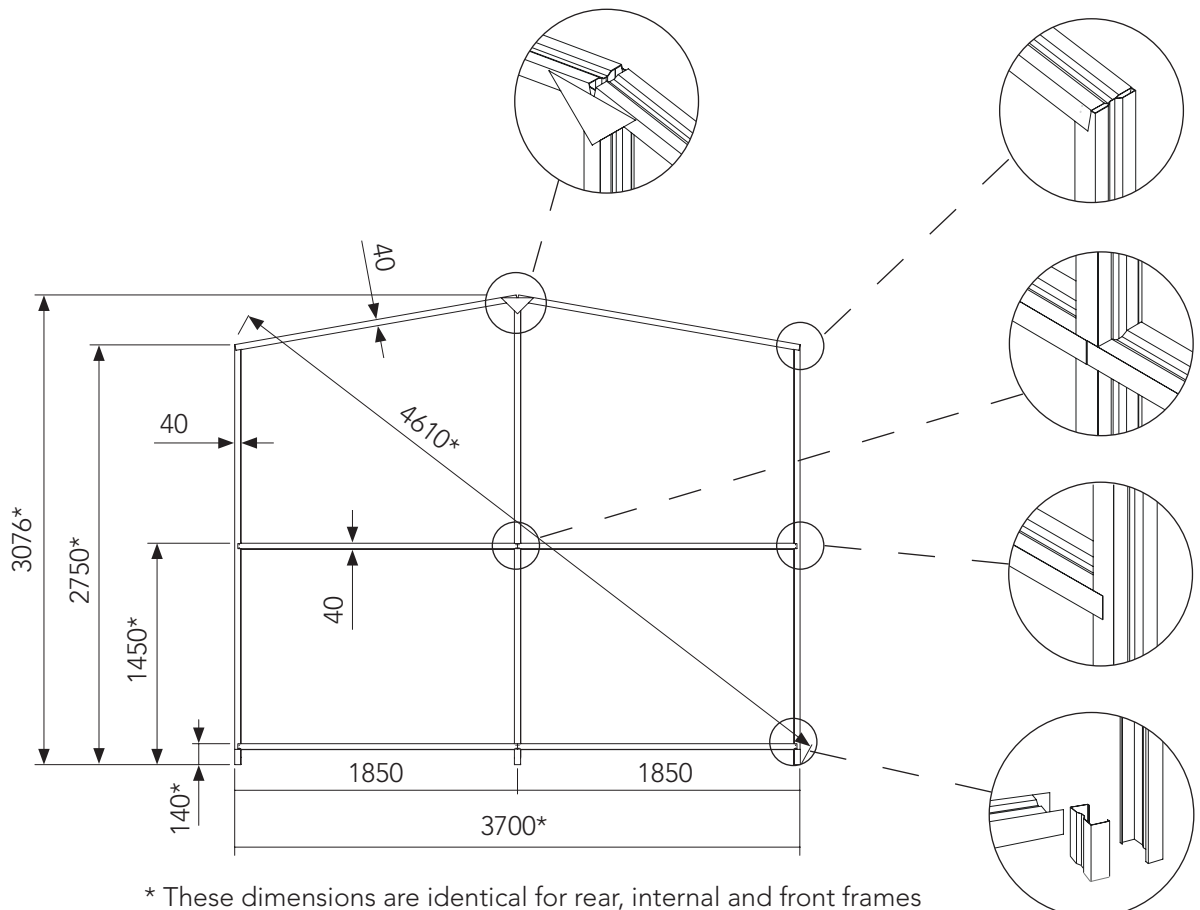
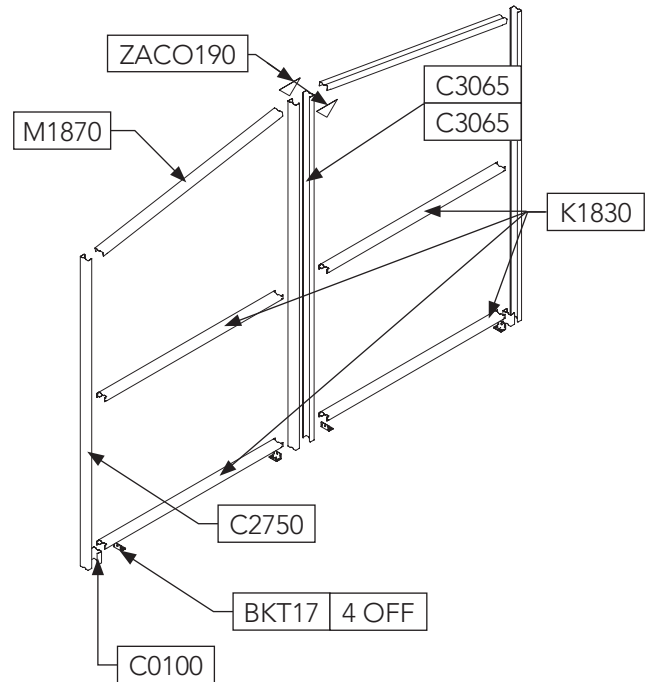

Internal Frame

2 Required.

1. Box these frame sections together with themselves.
1 OFF: C0370 + C0370
2 OFF: C2750 + C2750
2. Make a 3540 mm beam by boxing the following
2 OFF: 2x C2300 + 2x C1240
3. Attach centre web to mid point of beam with a ZACO180 plate both sides as shown
4. Fit the knee plates and apex plate over a pair of C1860 top chords. Angle is 10 degrees and width is 3700 mm
5. Take the top chord assembly and lay on top of the other assembly. Also add the C2750 uprights so they are flush with the outside of the knee plate
6. Carefully turn over
7. Repeat step 4 to make another top chord assembly and attach as per step 5.

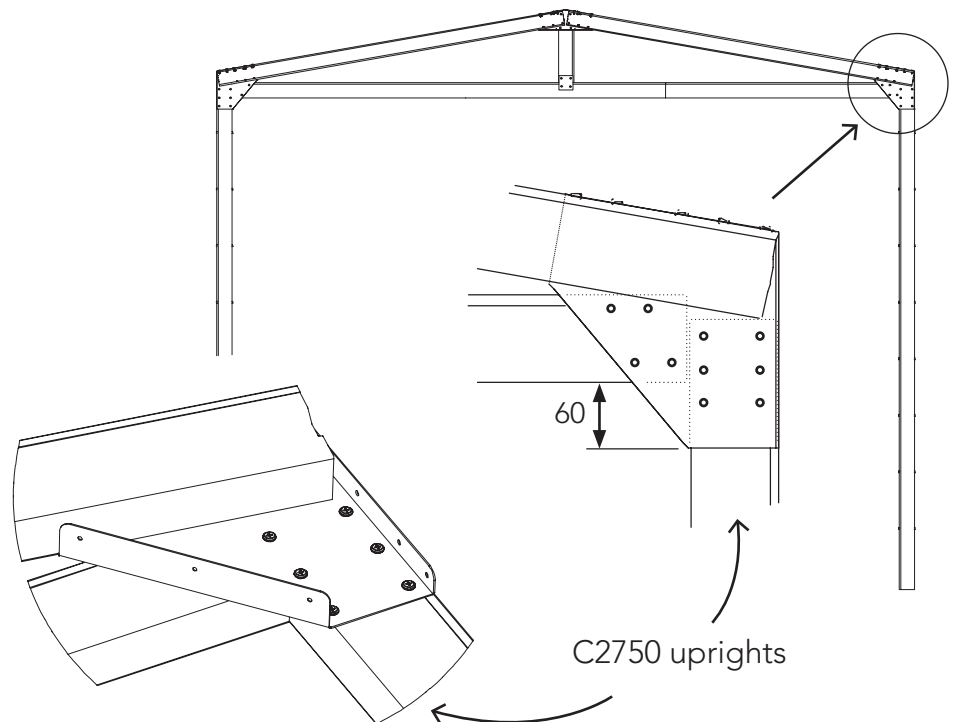
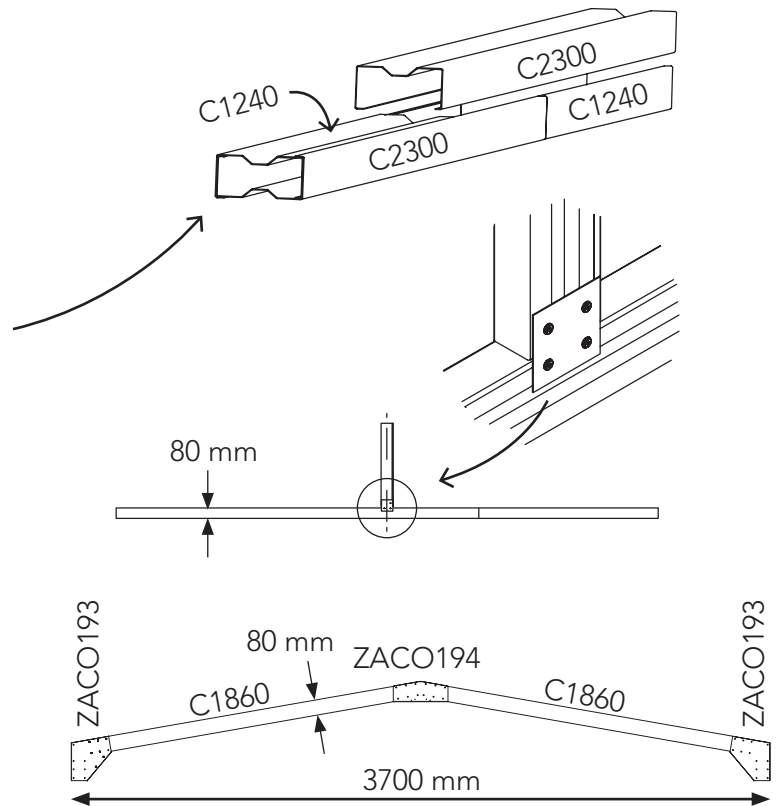

Front Frame

- Box these frame sections together.
1 OFF: C2400 + C2400
- Assemble the side mullions.
2 OFF: ZACO217 + ZACO217 + C2795
- Lay the components out as shown below, using the same dimensions as the rear frame. Fix with teks in the same manner.
- Take particular notice of the different views below to determine which way sections fit into others. Some pieces have end notching that must be orientated correctly.
- S1781 have cutouts that allow it to fit over the side mullions and other frame members.
- N1345 have one end notched to fit over side mullion.
- Do not fit the brackets BKT17, used for anchoring the frame to the slab at this stage.
- Refer to the engineering drawings for further fixing details.

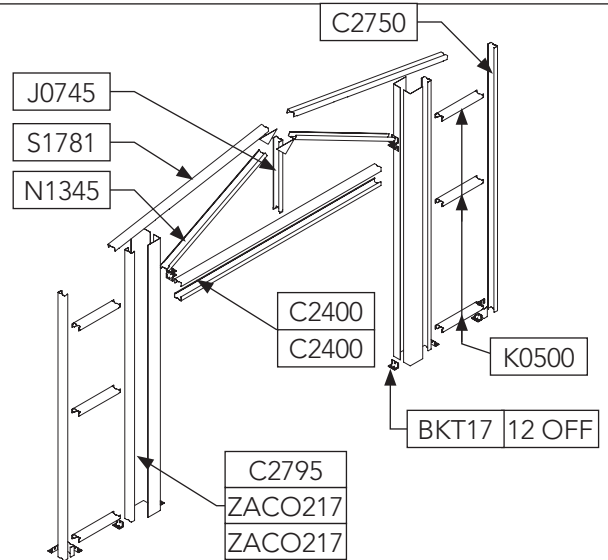

Side mullion assembly

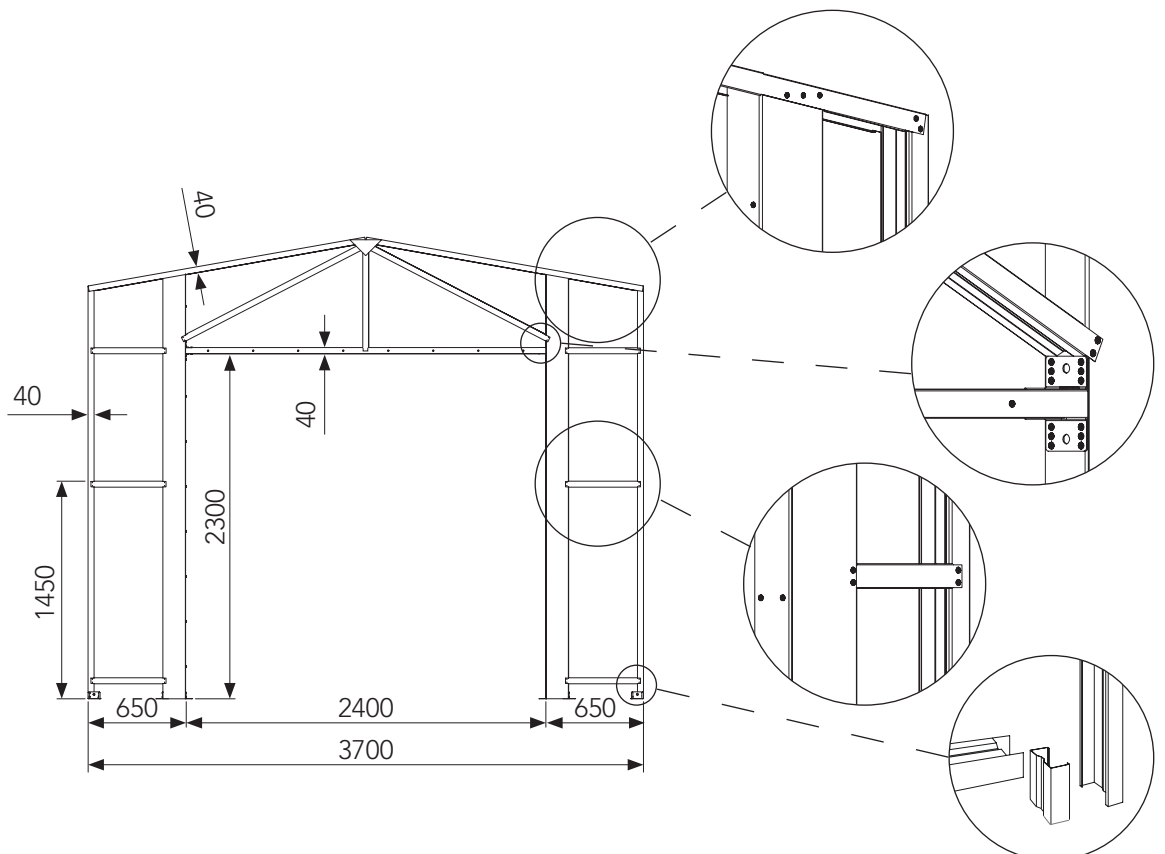
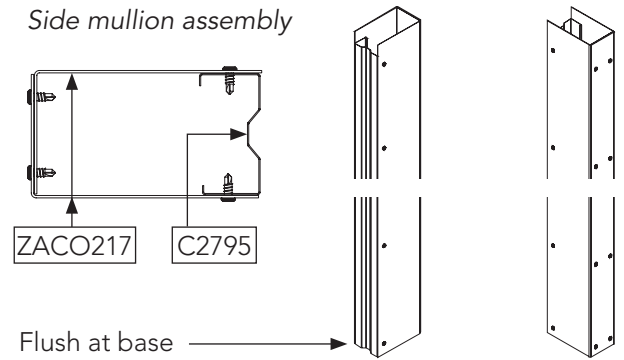

Front Frame

Add final bracing

- R0950 and R1335 end with tabs go over horizontal framing and the other end with open face notch slide into side mullion.

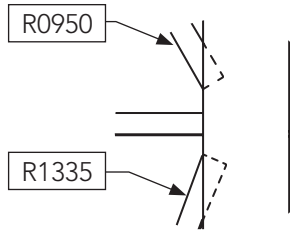

- Fasten with two teks per end
- Do for both sides

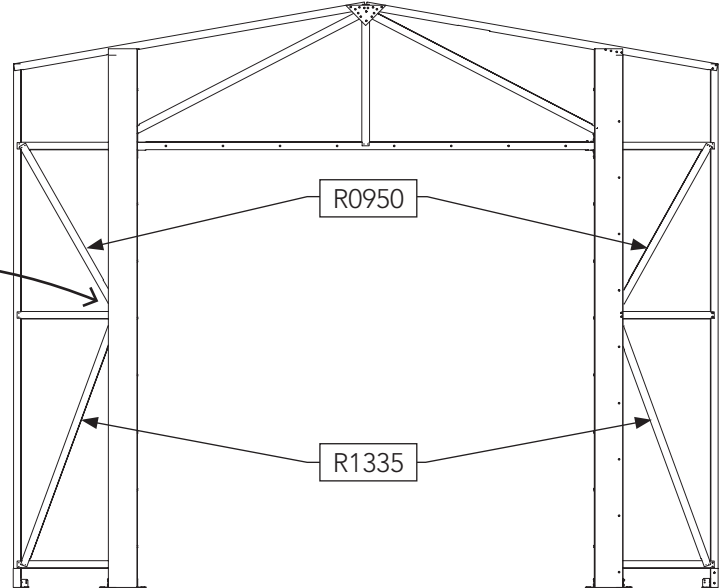

Slab Details and Anchoring Layout

ATTENTION

This slab detail is used for illustrative purposes and may not be suitable for your specific site.

As mentioned on page 1, you will need to contact a suitably qualified professional to specify concrete slab or footings for your site.

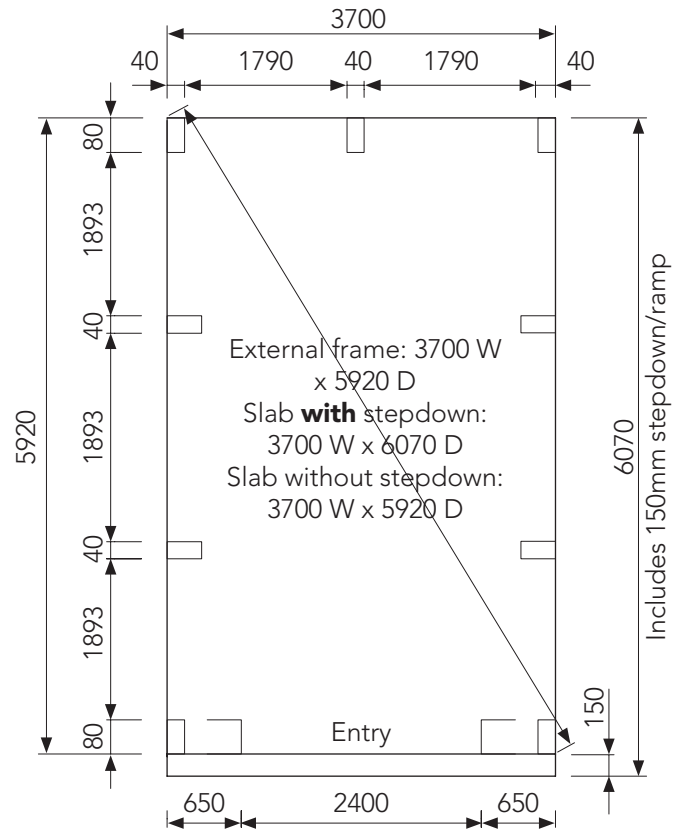

- The garage has been designed so that the slab and the external dimensions of the frame are the same. This allows the wall sheeting to overlap the top of the slab by 30mm and this prevents water entering the structure.
- If a front stepdown or ramp is added as recommended be sure to allow for the 30mm stepdown for the wall sheeting at the entrance.

PERIMETRE EDGE THICKENING

Applies to all four sides.

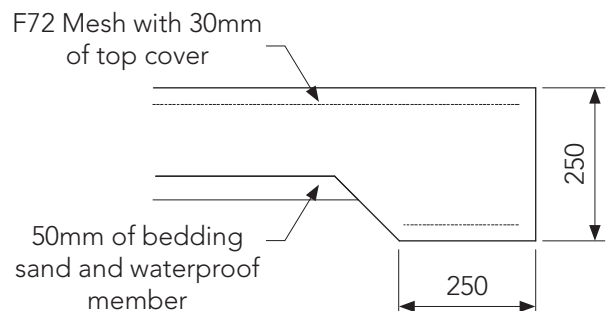

FRONT ENTRY STEPDOWN / RAMP

Adds 150mm to slab making it 6070mm front-to-back as noted above.

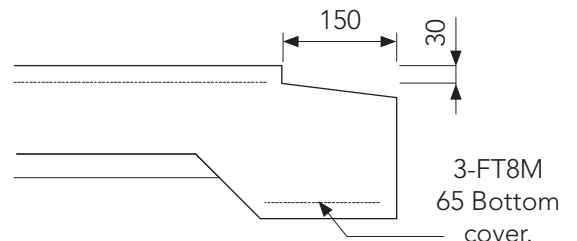

Anchoring Layout

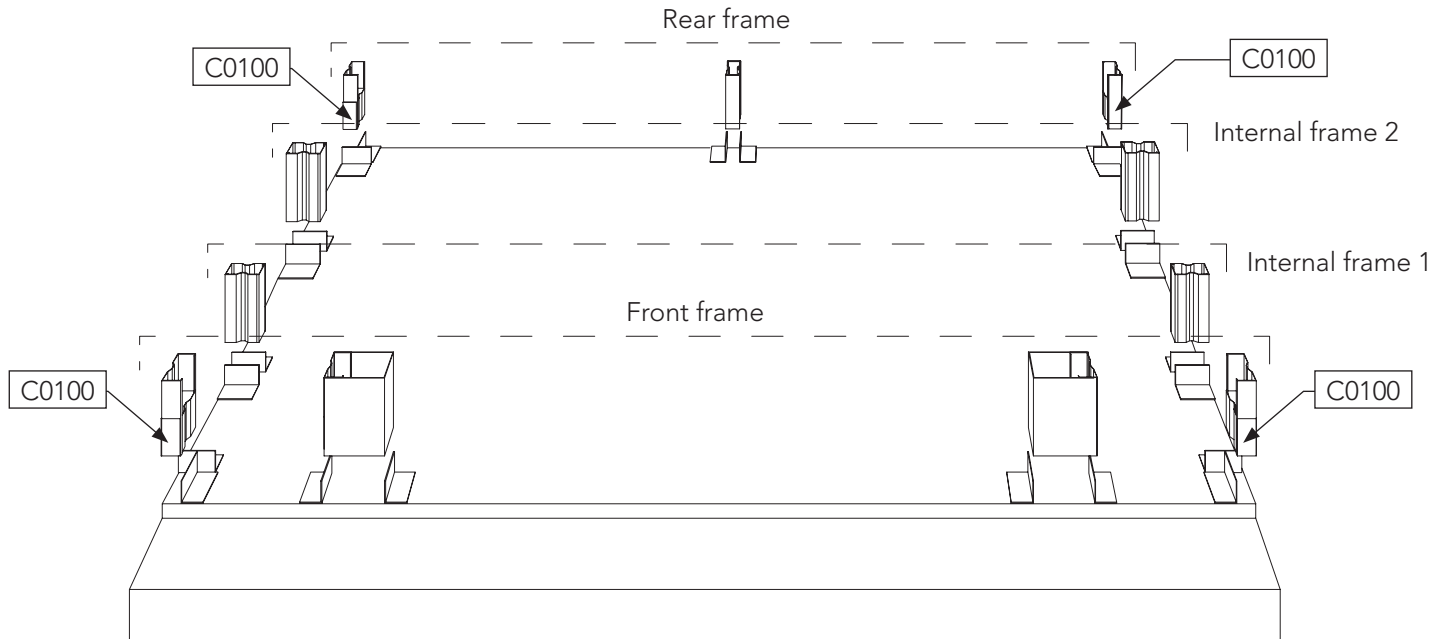

This image only shows the bottom of the frames and is not to scale.

- Fasten the multipurpose brackets (BKT17) to the frames as shown above while they are laying on the ground.
- Front and Rear frames will also require the C0100 be boxed into the bottom of both columns.
- Mark out the frame positions according to page 14. Misalignment between frames will result in the wall girts not fitting properly.
- Secure with tek screws, refer to the engineering drawing for the quantity of teks per bracket.
- When securing the BKT17 to the slab always use the bracket hole that is furthest away from the slab edge. This will prevent the possibility of the concrete cracking near the slab edge.

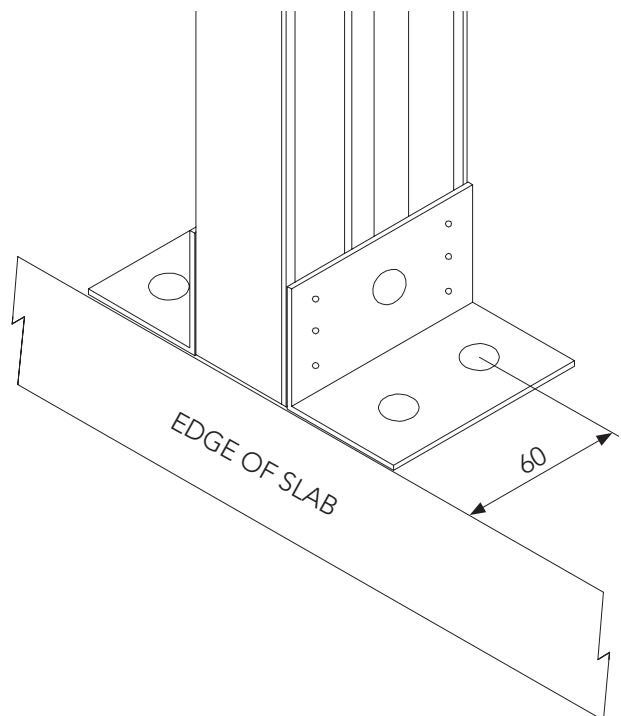

Frame Construction

0. General Anchoring Method

- To secure each frame to the slab, move the frame to its marked position. One person will need to hold the frame in position while another should mark the inner holes of the anchor brackets (BKT17).
- Move the frame away enough to get tool access and drill the slab for each anchor.
- Move the frame back into position and secure with anchors.

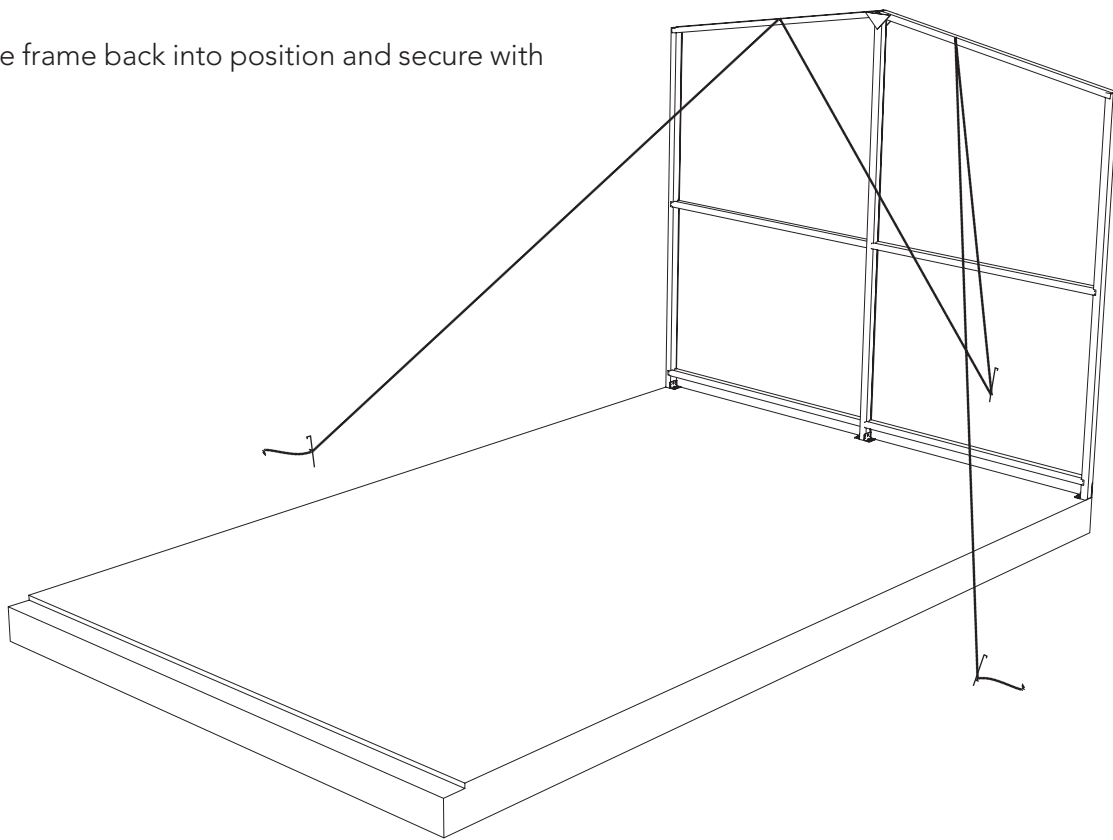

1. Rear Frame

- The rear frame can be supported with ropes and pegs or propped with the roof purlins (C2960) during this stage.

Frame Construction

3. Internal Frames

- Secure the first internal frame to the slab
- Fit the four side wall girts (K1933) to the same height as the rear wall girts.
- Bend the inside tab of the K1933's to a right angle so it can be fixed into the rear wall girt. See detail.

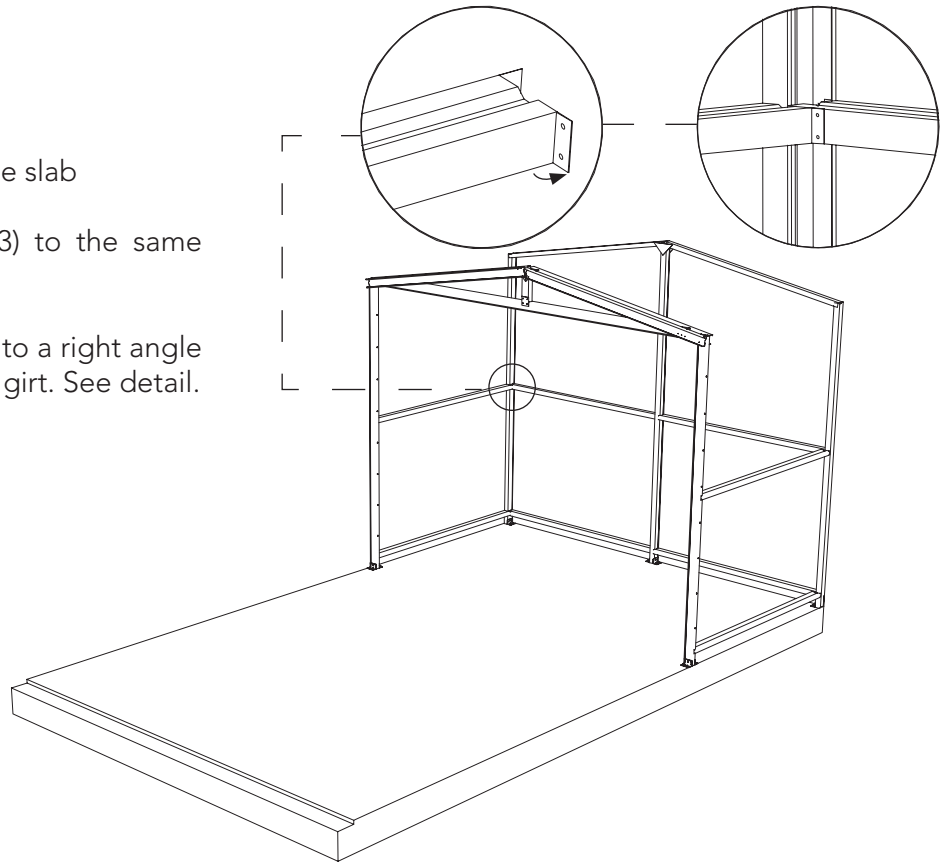

- To stabilise the structure secure two wall sheets as shown. Make sure that each wall sheet (286) overhangs the slab by 30mm and is 80mm past the top of the uprights.
- Fixings used for wall sheeting are hex head tek screws without neoprene washers (FAST035). Positioned in-line with the girts at every second sheet pan.
- The wall sheeting should poke out past the back frame 16.5mm to connect into the rear wall sheeting later. See page 21 for greater detail.

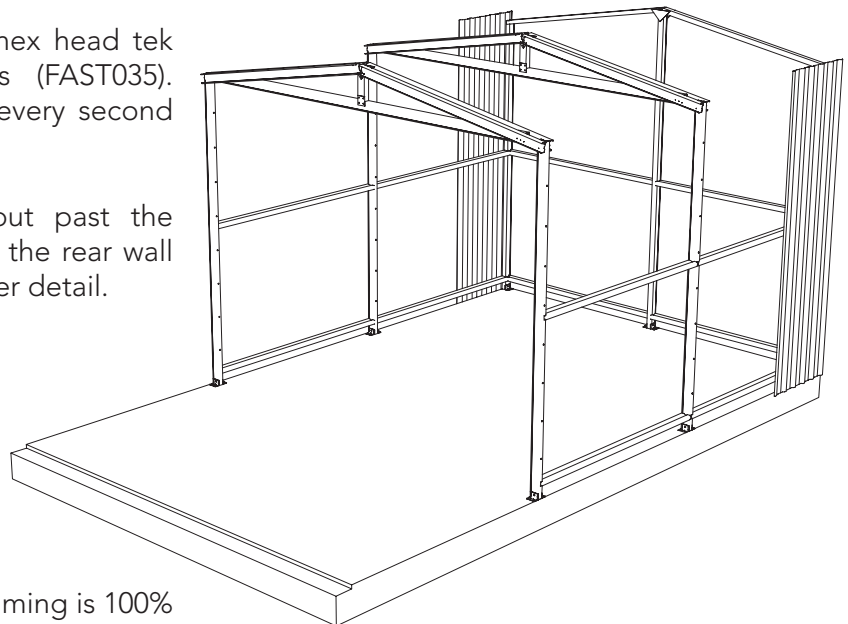

- Use a spirit level to check that the framing is 100% vertical. Use a tape to measure and check that the diagonal dimensions across the framework are equal.

Frame Construction

4. Remaining Internal Frame and Front Frame.

- Secure the remaining internal frame in the same manner as before. Checking everything is straight and square as you go.
- Connecting the side wall girts to front frame requires the tabs be bent at a right angle just like we did before with the rear frame.

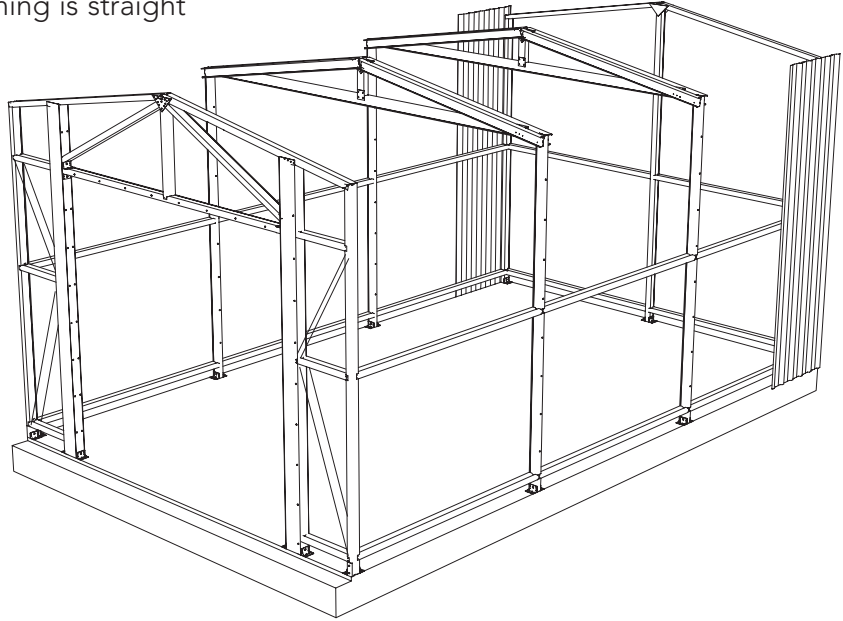

5. Fit Strapping

- Using a tape measure the roof diagonal dimension to make sure that the frame is exactly square.
- Fit the strapping (FAST040) diagonally over the top of the frames from corner-to-corner, pulling tightly and securing with three screws at every point that the strapping crosses the internal frames.
- Repeat this procedure for the rear frame
- Repeat this for both sides of the two internal frames

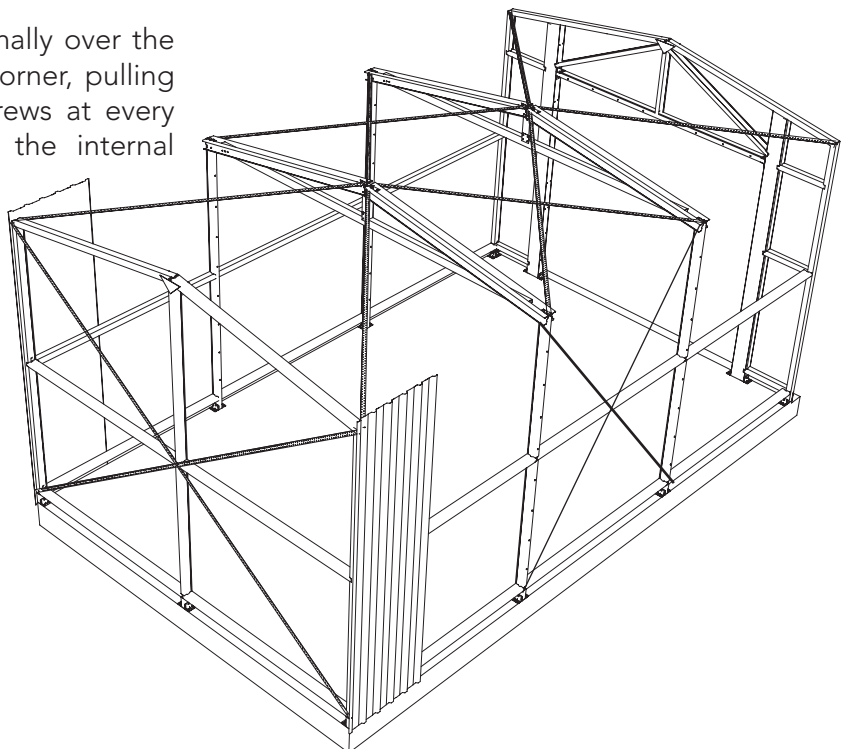

Roof Purlins

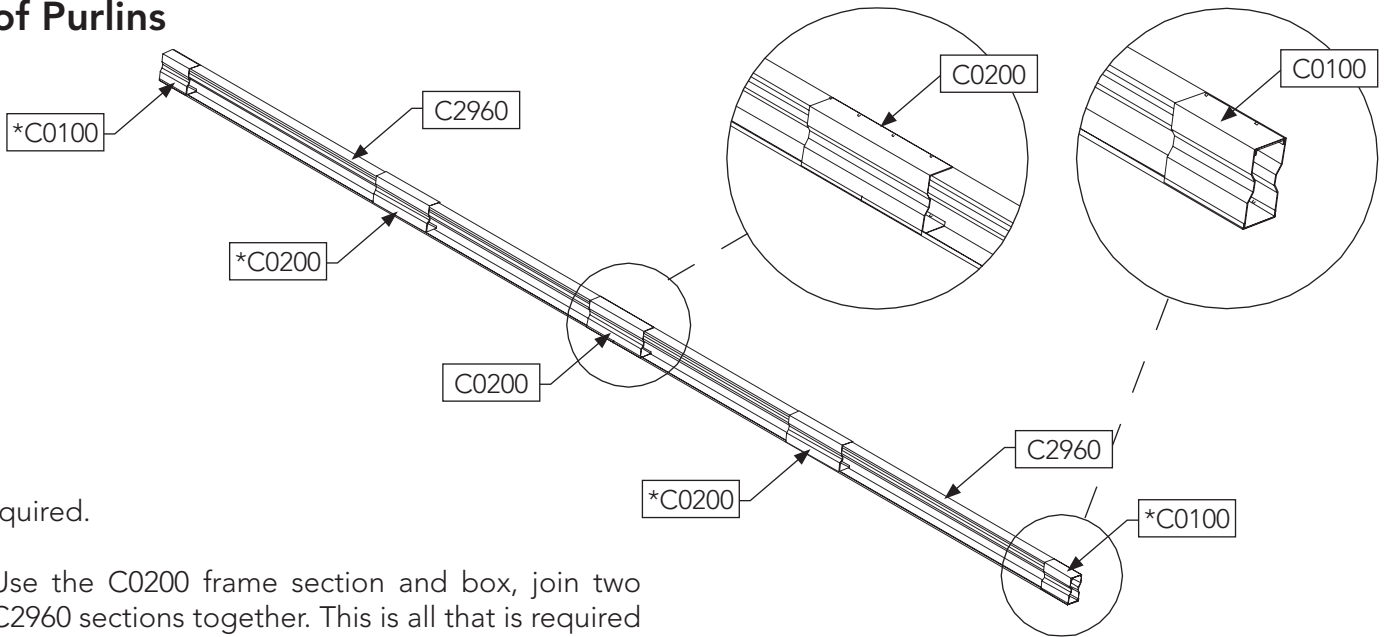

8 Required.

- Use the C0200 frame section and box, join two C2960 sections together. This is all that is required for six of the eight purlins.
- The remaining two purlins must also have:
*C0100 section at either end.
*C0200 section at the Internal Frames.
- These two purlins are to be positioned at the wall directly above the frame uprights, as shown on the right.
- These two outer-most purlins are to be spaced 15mm in from the edge of the roof chords so the wall sheeting can be fixed top the purlin.
- Using a string line mark the top of the frames referencing the dimensions below.

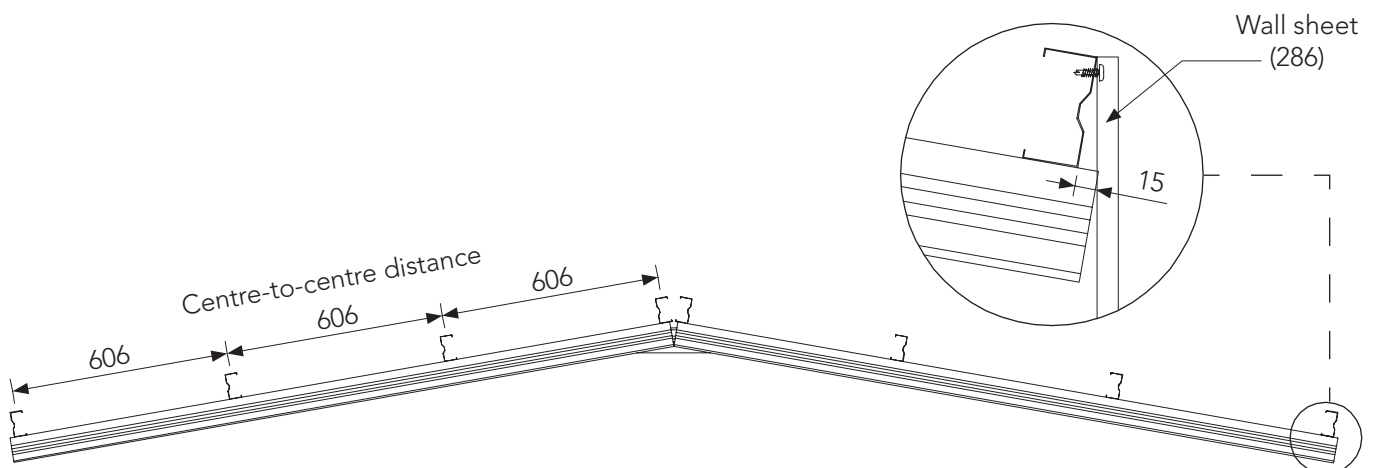
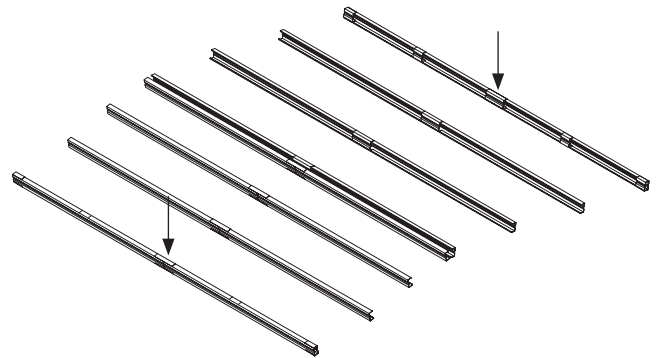

Secure Roof Purlins

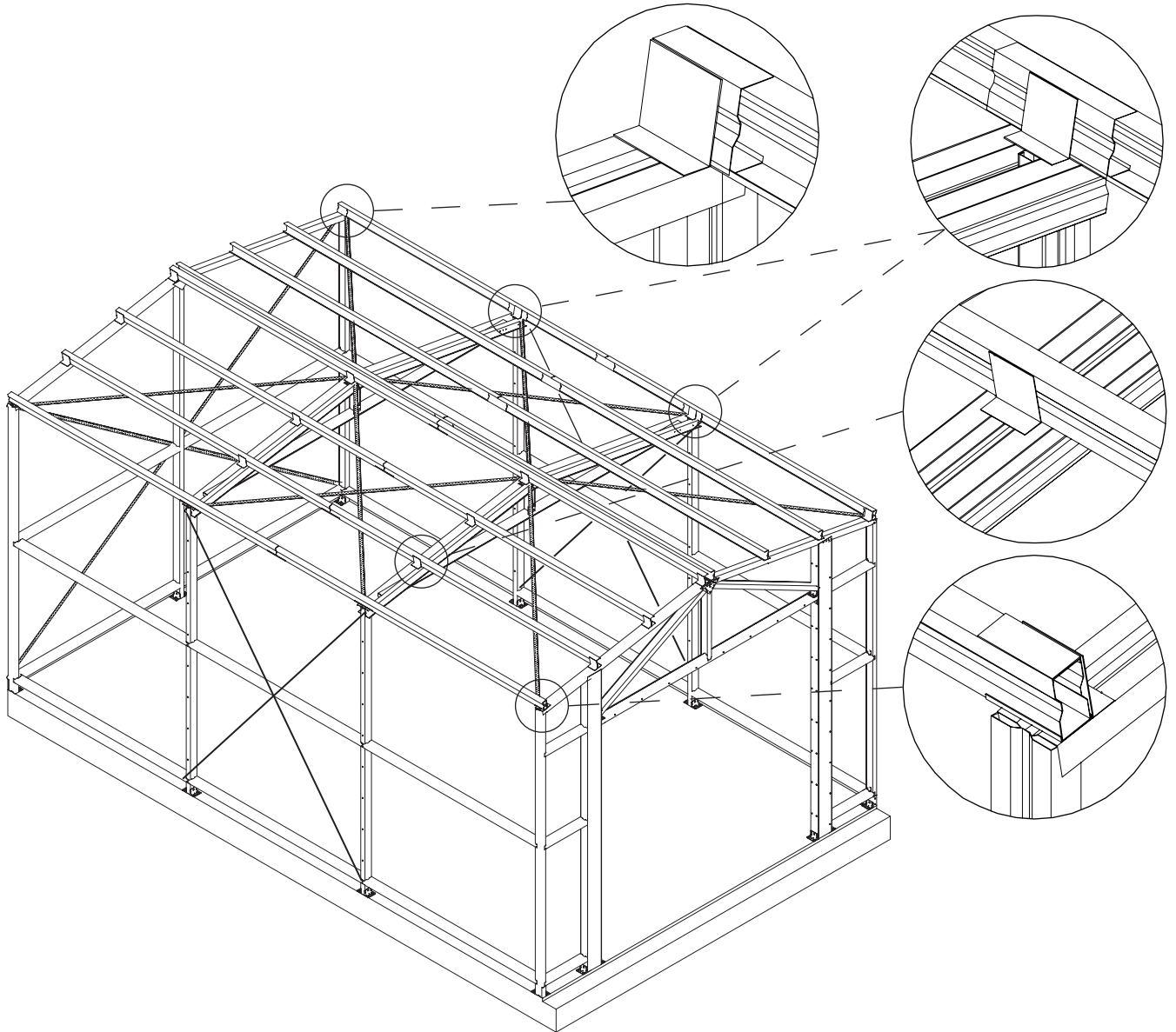

- Secure purlins to the framework as shown with one roof purlin bracket (BKT11) at each connection point.
- Front and Rear frames use 8x tek screws per connection.
- Internal frames use 12x tek screws per connection.

Fly Bracing

- Fly braces are struts that attach both sides of the internal frame up to the centre-most purlins.
- The four fly-braces, ZACO124B, need to have one end cut.

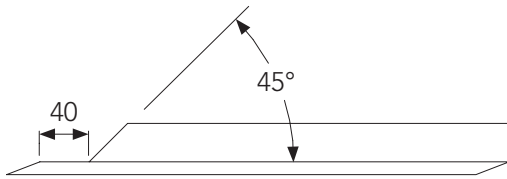

- Bend the tab as shown

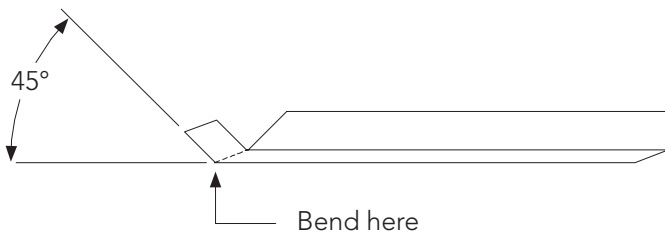

- The braces are positioned at 45 degrees from the roof purlin to the underside of each frame and fixed with tek screws.

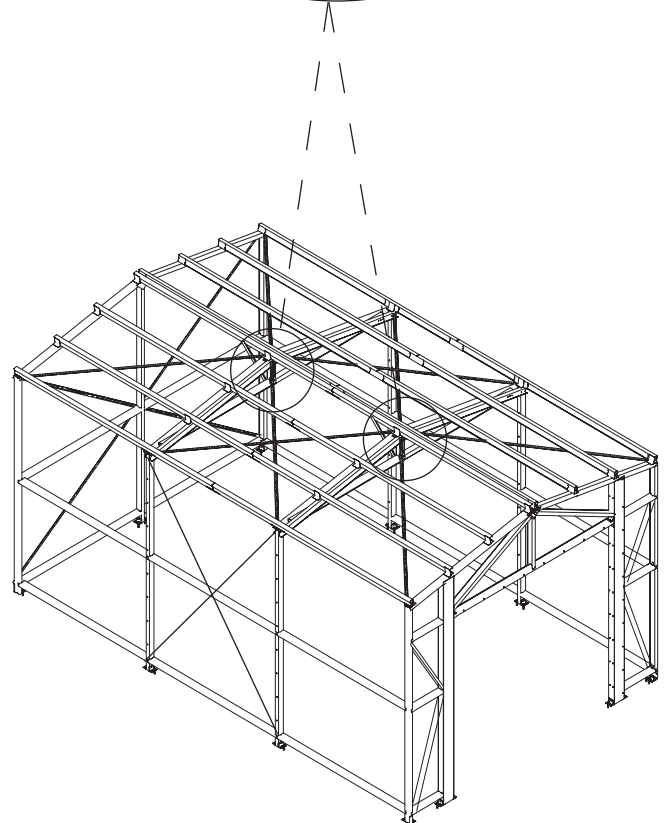
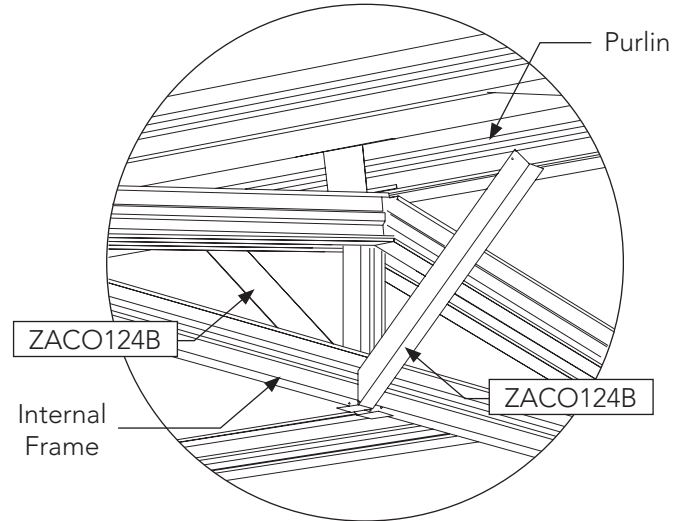

TRIM SHEETS

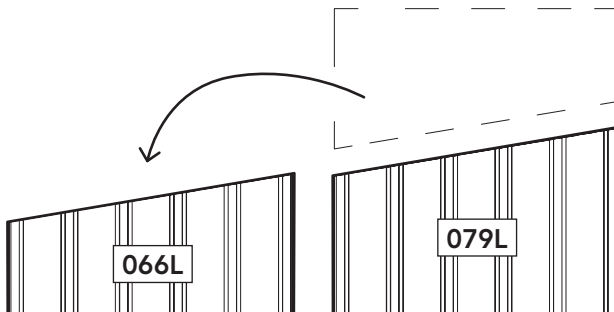
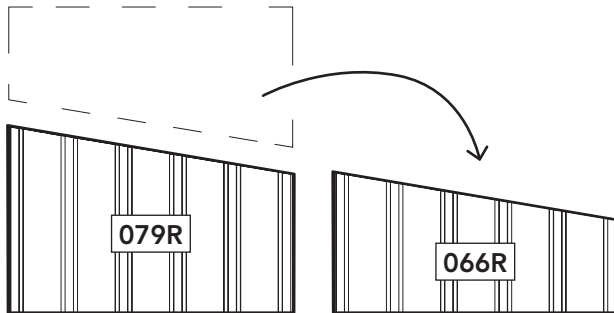
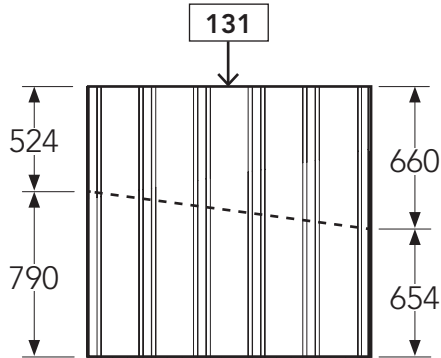

1. Take a **131** sheet and mark along the edges as per the dimensions shown.

2. Using a straight edge & marker or chalk line mark the angled line and carefully cut.

TIP: This cut edge will be covered by barge flashing.

3. You'll have two pieces.
a **066R** and a **079R**

4. Now take the other **131** sheet and mark the angle the opposite way to make gable sheets **066L** and **079L**.

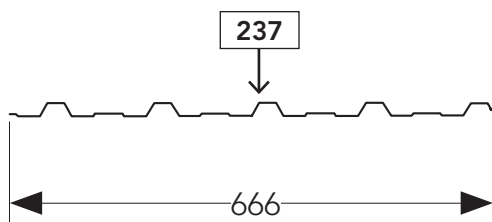

1. Cut off one side of the **237** sheet so final width is 666 mm.
Do this for both sheets.

Wall Sheeting

Vertical Positioning

- Position each sheet flush with the top of the roof purlin so that the bottom end overlaps the concrete slab by 30mm to form a weather-tight seal.

Horizontal Position

- A typical sheet overall width is 773mm.
- When multiple sheets are installed with the typical one rib overlap the sheet-to-sheet coverage is 740mm.
- The wall length of this garage is 5920mm and it is made up of eight sheets
 $8 \times 740\text{mm} = 5920\text{mm}$
- This dimension is also the frame and slab size.
- As the coverage-to-coverage of a sheet and its actual width are different the sheets on either end of the wall will extend past the framing by 16.5mm. This is used to fix into the other corner sheet neatly.

- Using a stringline and spirit level to identify and fix misalignments as you go.
- Fix through every second pan into the top and bottom girts, outermost purlin and frame uprights where possible.
- The coverage of each sheet can vary slightly so it is important to keep checking as you go.
- As stated previously the last sheet in the wall must overhang by 16.5mm. You can stretch or shrink the sheeting coverage as you lay each sheet to accomplish this.
- The short angled front wall sheets are to have their straight edge aligned with underside of the header beams.
- The narrower side sheets for the front wall (237-1) have a raw edge, position as shown.
- The narrower side sheets for the front wall (237-1) are to be placed before/behind the shorter angle sheets. Align the top edge of this sheet with the topside of the header beam, this will make a 30mm overhang of the slab edge.

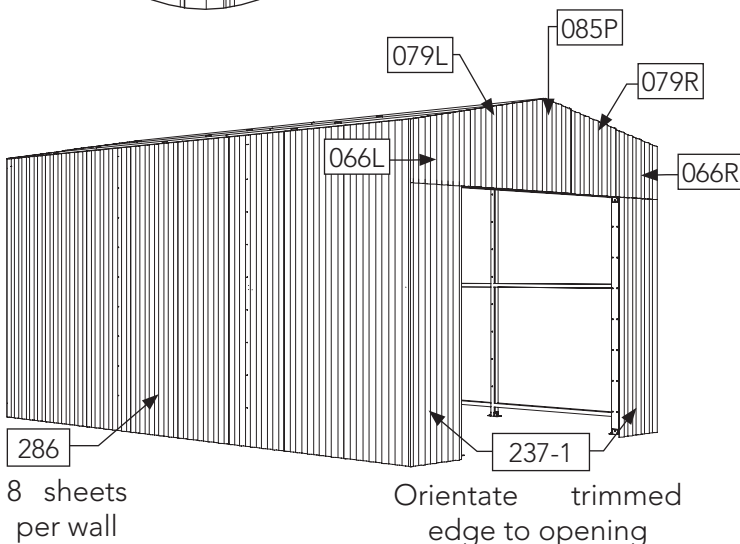
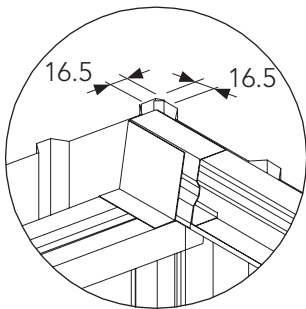

Front left view

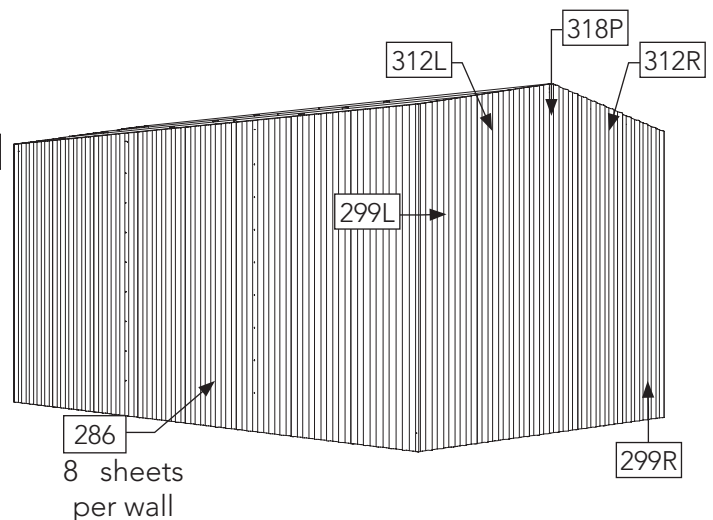

Back right view

Roof Sheeting

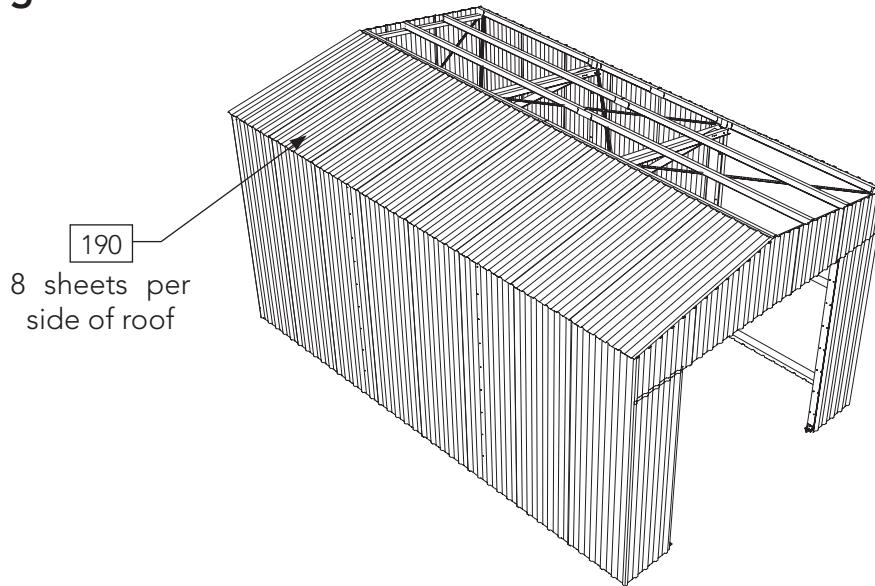

- On the ground, lay out the roof sheeting as if they were on the frame already. Using a piece of wood, as pictured, turn up the pans of each sheet at the end that's going to be at the ridge. This will prevent rainwater entering the structure during windy conditions.
- Avoid walking on the roof so sheeting is not damaged. If it is necessary, walk only on the pans at purlin locations after sheets have been secured.

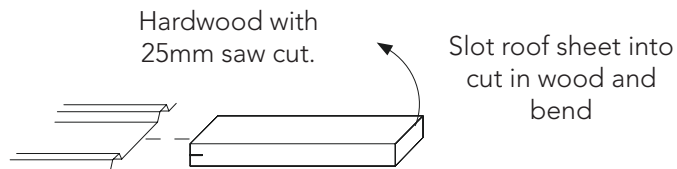

- Use one Hex head tek screw with neoprene washer (FAST033) at every second pan to ridge and outer purlins.
- Use one Hex head tek screw with neoprene washer at every second pan to the middle purlins.
- Lay the ridge capping (TR30) centrally on the roof, overlapping the sections to make the same length as the roof sheeting. Fix the capping to every second rib of the roof sheets beneath it.
- Fit the roof sheets in the same manner as the wall sheets. Each sheet should line up with the side wall sheet.
- The roof sheets should overhang the side wall sheet by 30mm to allow water to run into the gutters when installed.

Guttering + Downpipe

- Join lengths of gutter TR22, to match the length of the shed by notching the roller edge of one to allow the other to slide into it.
- Put silicone in the joint and then use rivets, FAST009, to fasten the sections together.
- Repeat this for the other side.
- Mark the rectangular cutout to suit the downpipe drop RWG18 at the end you select.
- Remove material and fix RWG18 with silicone and rivets.
- Mark a line 110mm down from the top of the outer purlins at either end of the shed. Run a stringline between these marks. This is a reference to align the bottom position of the gutter brackets, RWG06.
- RWG06 are to be fixed to the sheeting rib at either end and spaced equally along the shed length.
- You may wish to allow for a slight fall to the downpipe position.
- Fix gutter onto brackets equally at both ends, push top of bracket into outer roll of gutter and bend small support arm down to hold the inner face.
- Rivet the brackets to the gutter through the bottom of each bracket.
- Fit downpipes to drops with silicone and rivets. Secure to wall sheeting with downpipe strap bent to suit.

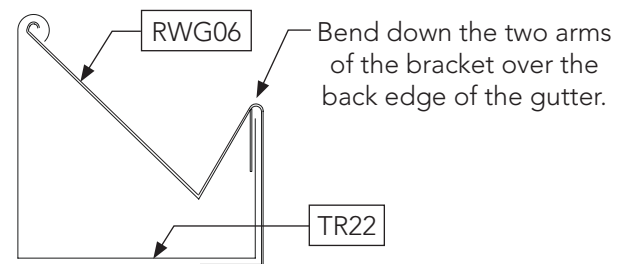
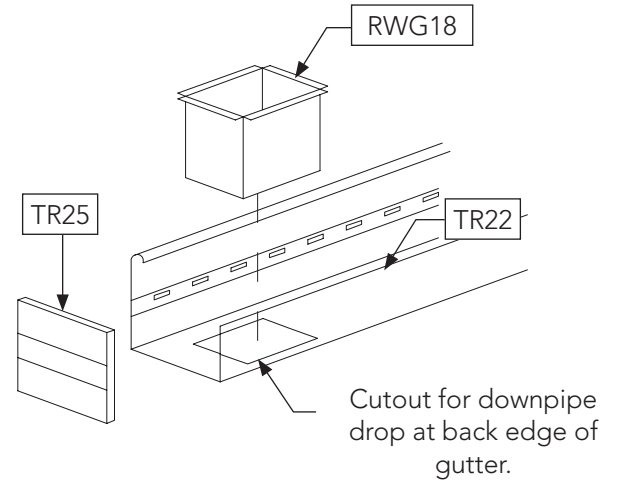

Barge Capping and Trim

- Fit barge capping (TR06) to the front and rear gables, fixing where there is a purlin beneath it.
- Fit TR21 between sheet and frame directly above roller door. Two lengths will be required.
- Measure and cut TR19 to suit either side of roller door opening, covering the raw edge of 237-1.

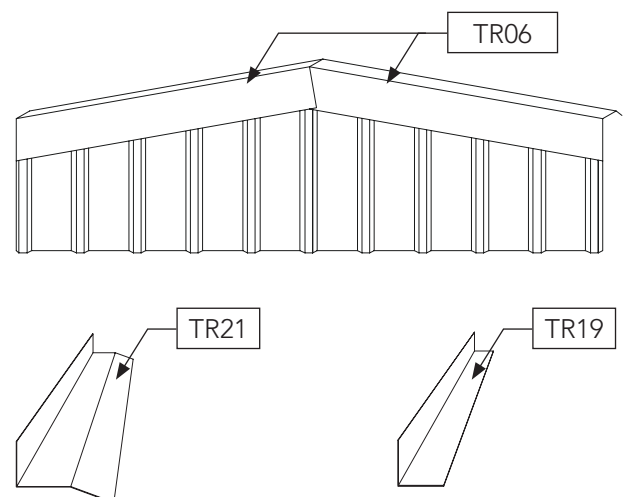

Roller Door Installation

- These instructions and components are located with the roller door.
- FAST081 are to be used to fix roller door guides.

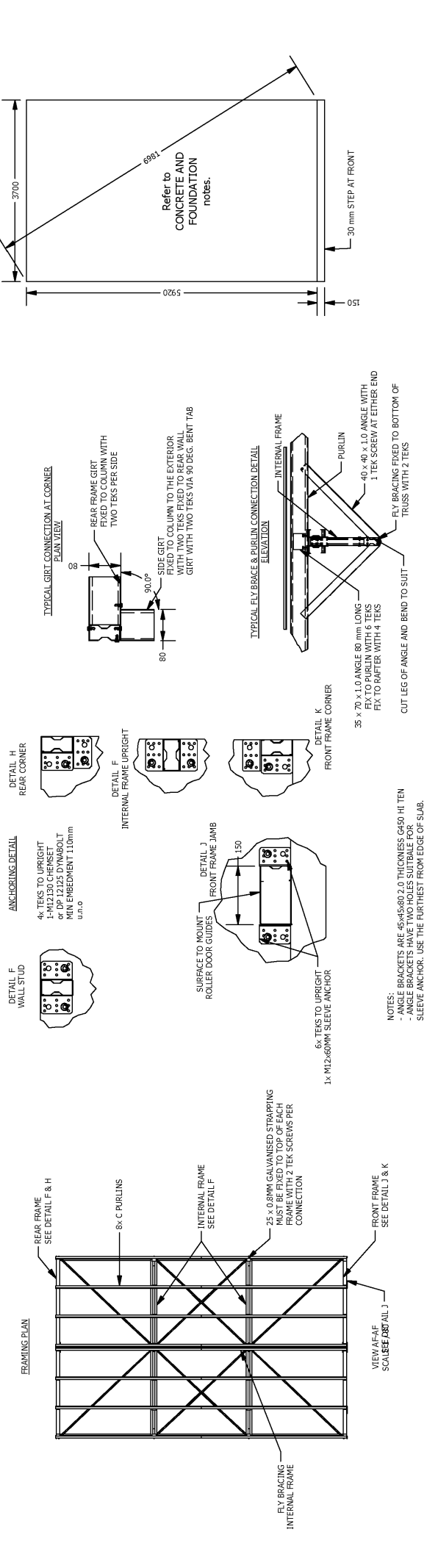
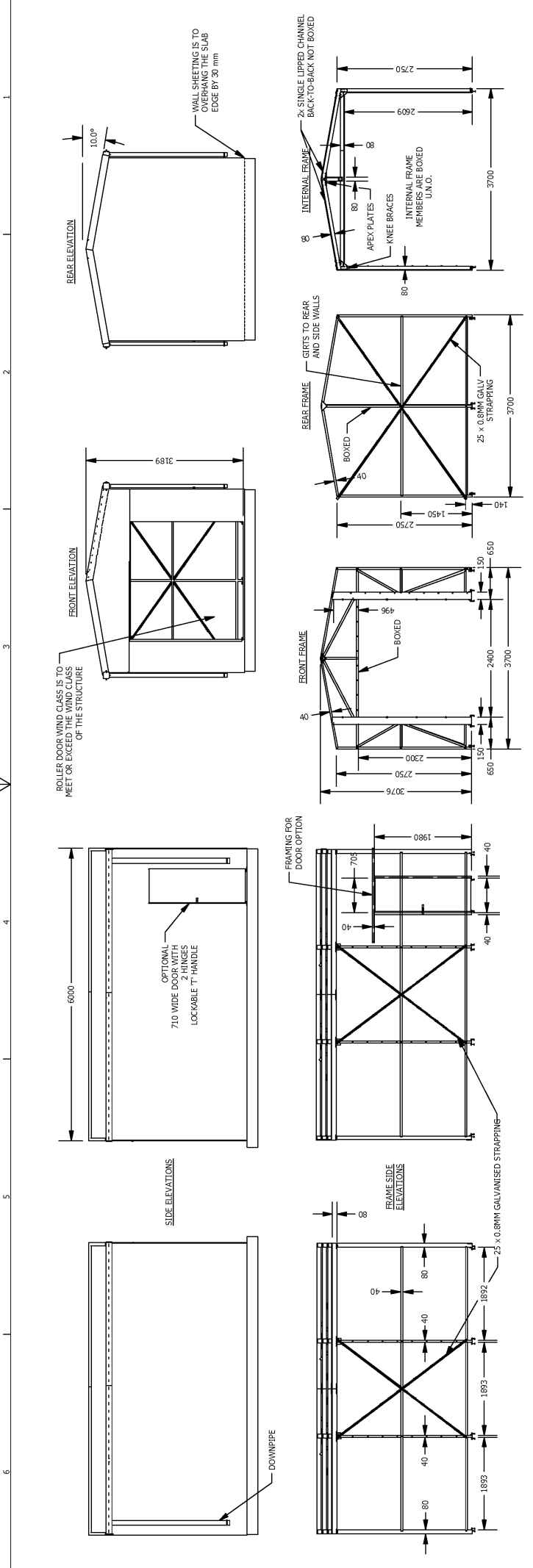

DRAWN		SJC		10/07/2024		ABS-GR231		3.7m x 6.0m GARAGE WITH ROLLER DOOR	
CHECKED		MZ				ABS-GR231		WIND CLASS N2	
TECH APPROVED		MZ				ABS-GR231		WIND CLASS N2	
SIZE		A3		SCALE		1 / 80		REV	
SHEET		1		2024-1		1		OF 2	

ABSICO SHEDS
So Tough. Too Easy.

This document contains confidential and proprietary information. It is to be used only for the project it is intended for. No part, without written authorisation from ABSICO INDUSTRIES

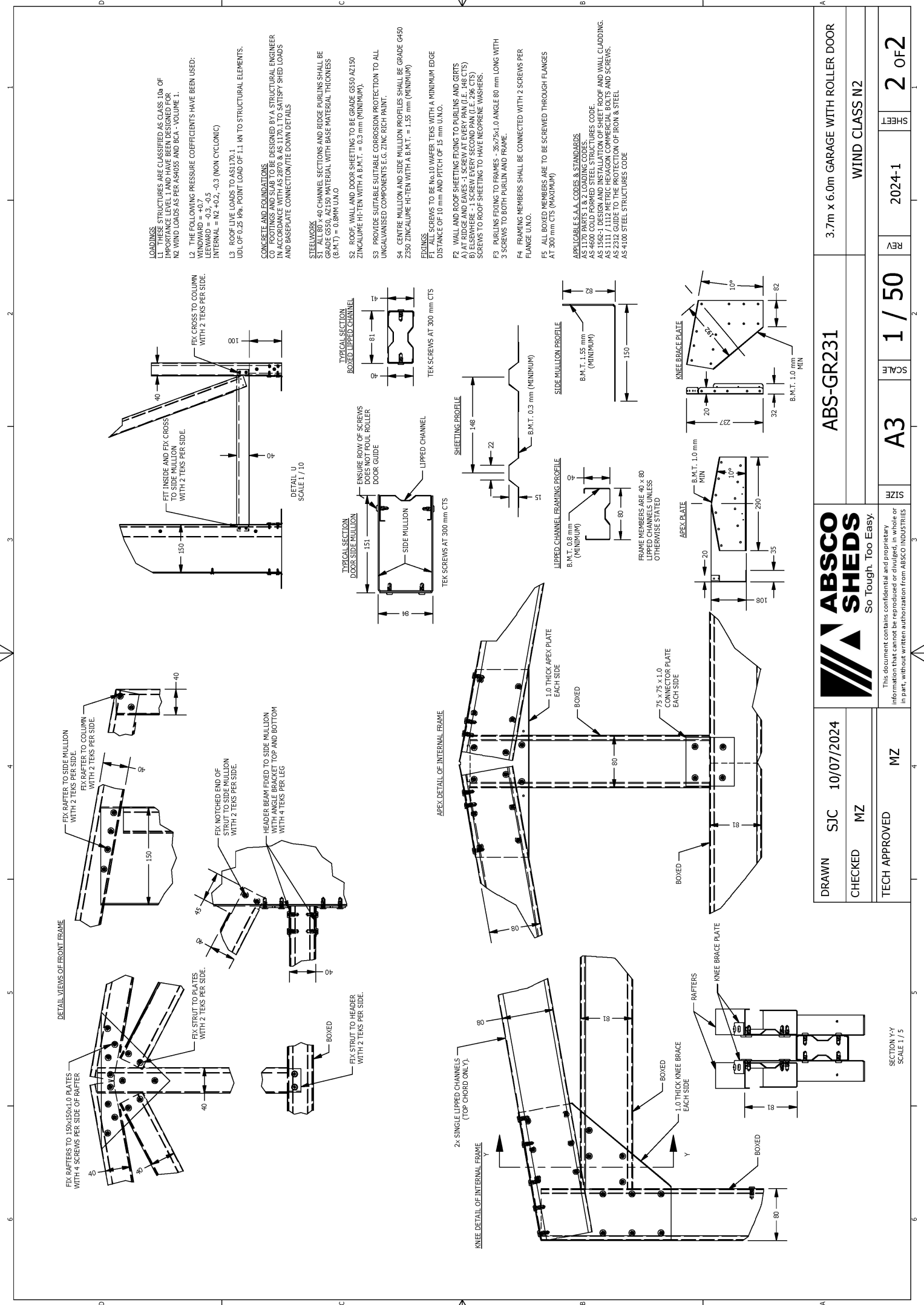

LOADINGS
 L1 THESE STRUCTURES ARE CLASSIFIED AS CLASS 106 OF IMPORTANCE LEVEL 1 AND HAVE BEEN DESIGNED FOR N2 WIND LOADS AS PER AS4505 AND BCA - VOLUME 1.
 L2 THE FOLLOWING PRESSURE COEFFICIENTS HAVE BEEN USED:
 WINDWARD = +0.7
 LEeward = -0.3, -0.5
 INTERNAL = N2 +0.2, -0.3 (NON CYCLONIC)
 UDL OF 0.25 kPa POINT LOAD OF 1.1 kN TO STRUCTURAL ELEMENTS.

CONCRETE AND FOUNDATIONS
 C0 FOOTINGS AND SLAB TO BE DESIGNED BY A STRUCTURAL ENGINEER.
 C1 ALL CONCRETE TO BE CAST WITH 5% CRACK RESISTANT FIBRE AND BASEPLATE CONNECTION/DIE DOWN DETAILS.

STEELWORK
 S1 ALL 80 x 40 CHANNEL SECTIONS AND RIDGE PURLINS SHALL BE GALVANNEAL WITH BASE MATERIAL THICKNESS (B.M.T.) = 0.8MM U.N.O.

S2 ROOF, WALL AND DOOR SHEETING TO BE GRADE G550 AZ150 ZINCALUME H-TEN WITH A B.M.T. = 0.3 mm (MINIMUM).
 S3 PROVIDE SUITABLE SUITABLE CORROSION PROTECTION TO ALL UNGALVANISED COMPONENTS E.G. ZINC RICH PAINT.

S4 CENTRE MULLION AND SIDE MULLION PROFILES SHALL BE GRADE G450 Z350 ZINCALUME H-TEN WITH A B.M.T. = 1.55 mm (MINIMUM)

FIXINGS
 F1 ALL SCREWS TO BE No.10 WAFER TEKS WITH A MINIMUM EDGE DISTANCE OF 10 mm AND PITCH OF 15 mm U.N.O.

F2 WALL AND ROOF SHEETING FIXING TO PURLINS AND GIRTS
 A) AT RIDGE AND EAVES - 1 SCREW AT EVERY PLY (I.E. 146 CTS) (MINIMUM)
 B) AT INTERMEDIATE PURLINS - 2 SCREWS AT EVERY PLY (I.E. 146 CTS) (MINIMUM)
 C) SCREWS TO ROOF SHEETING TO HAVE NEOPRENE WASHERS.

F3 PURLINS FIXING TO FRAMES - 35x75x1.0 ANGLE 80 mm LONG WITH 3 SCREWS TO BOTH PURLIN AND FRAME.
 F4 FRAMING MEMBERS SHALL BE CONNECTED WITH 2 SCREWS PER FLANGE U.N.O.
 F5 ALL BOXED MEMBERS ARE TO BE SCREWED THROUGH FLANGES AT 300 mm CTS (MAXIMUM)

APPLICABLE S.A.A. CODES & STANDARDS
 AS 1170 PARTS 1 & 2, LOADING CODES.
 AS 4600 COLD FORMED STEEL STRUCTURES CODE.
 AS 1562-1 DESIGN AND INSTALLATION OF SHEET, ROOF AND WALL CLADDING.
 AS 1111 (1112 METRIC HEXAGON COMMERCIAL BOLTS AND SCREWS.
 AS 1163 (1164 METRIC HEXAGON COMMERCIAL WASHERS AND NUTS).
 AS 4100 STEEL STRUCTURES CODE.

DRAWN SJC 10/07/2024		ABS-GR231		3.7m x 6.0m GARAGE WITH ROLLER DOOR	
CHECKED MZ		SCALE	A3	REV	2024-1
TECH APPROVED	MZ	SIZE	1 / 50	SHEET	2 OF 2
		WIND CLASS N2			



This document contains confidential and proprietary information. It is to be used only for the project specified in part, without written authorisation from ABSICO INDUSTRIES.

SECTION Y-Y
SCALE 1 / 5

Installing Mounting Brackets

Make sure that top of bracket is 150mm up from the underside of the header beam otherwise opening height will be reduced. Horizontally, position outer bracket on edge of side mullion.

Ensure brackets are level using laser or water level.

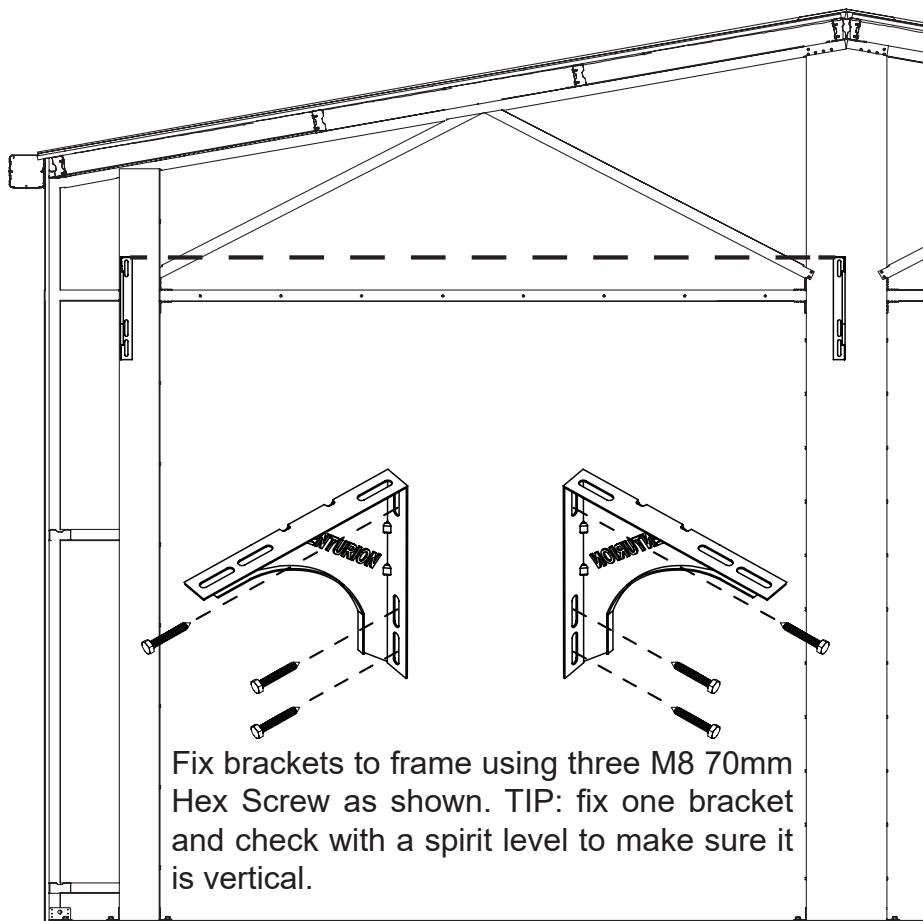
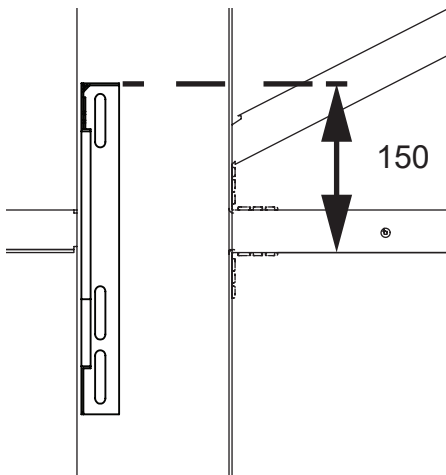

Centralise and Lift Door

Place the door on the ground inside the opening and make sure it is orientated the right way around.

When standing outside the garage "CENTURION" on the handle should be the right way up.

Centralise the axle of the roller door by both twisting and pushing it at the same time.

Wipe grease and mark axle with a permanent marker on both sides to make sure you can tell it has remained centred on after the lift

Safely lift the door onto the brackets.

Place shaft onto saddles and hand tighten Hex Flange Nut 5/16" onto the U-bolt.

Make sure that it is not overtightened, we need to check that the door is centred over the opening.

Centre the door in the opening by adjusting the axle position on the brackets.

DO NOT ADJUST BY MOVING THE DOOR CURTAIN ON AXLE.

Check it is still centralised on the axle by seeing the markings on axle.

Now fully tighten U-bolts on both sides.

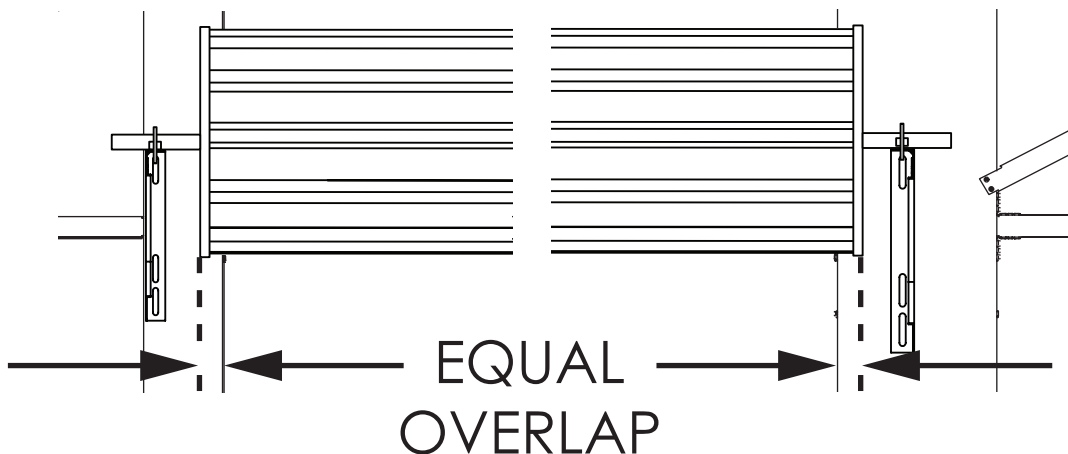
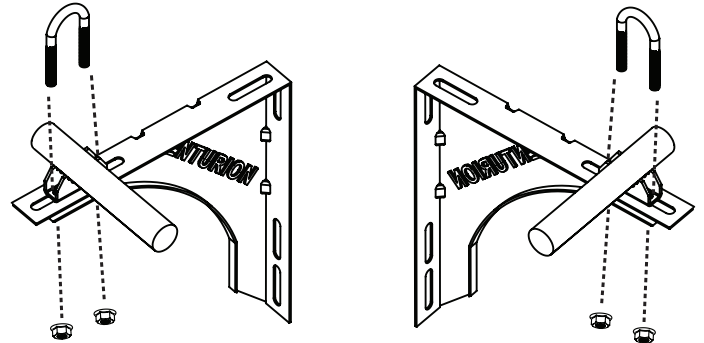
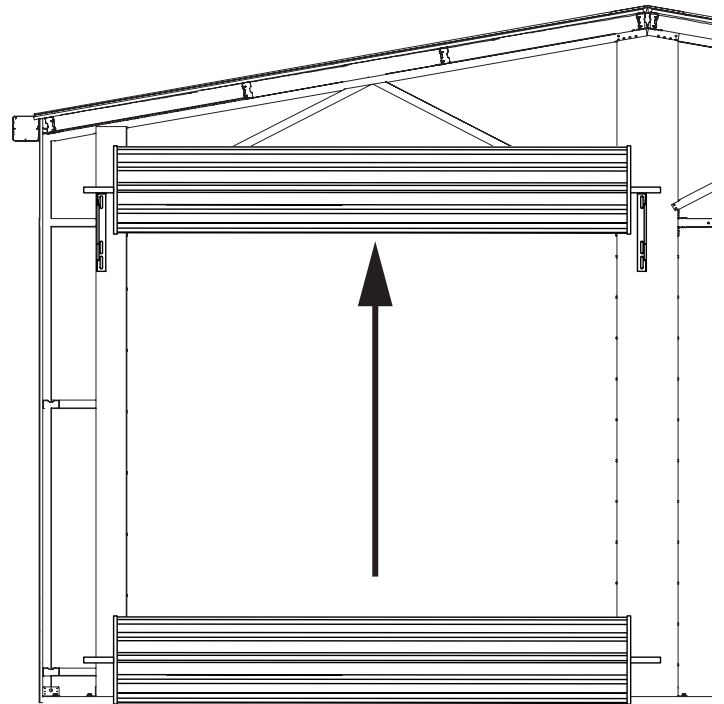

Apply Tension To Door

1.
With the door now fixed to the brackets we need to apply tension. This can be done by rotating the door assembly 2 turns. Be sure to turn it the direction indicated.

Now the door is tensioned additional care must be taken, don't let it go.

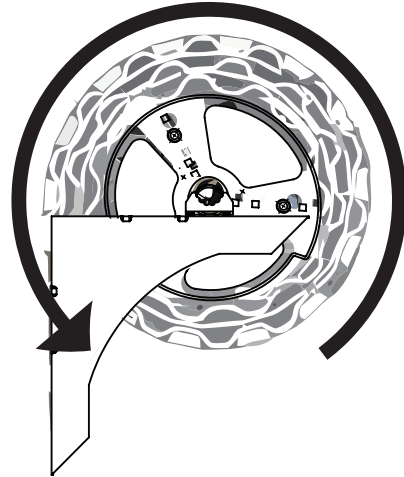

2.
Pull down the door and remove all plastic wrapping, cardboard and other protective coatings. Be sure to remove them from both sides,

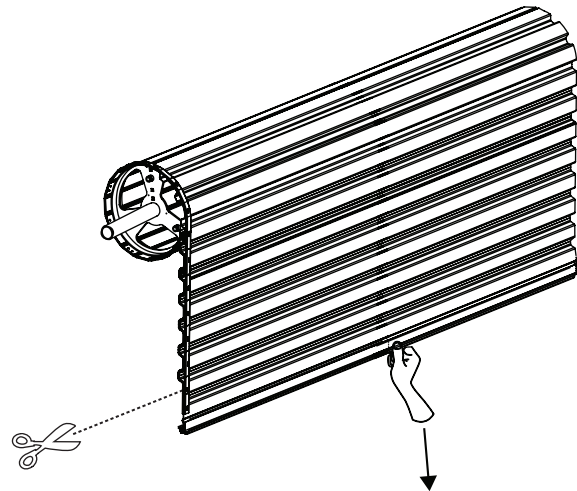

3.
The door can be held in position by placing a soft wood chock as shown. 300 mm is a good distance to work with.

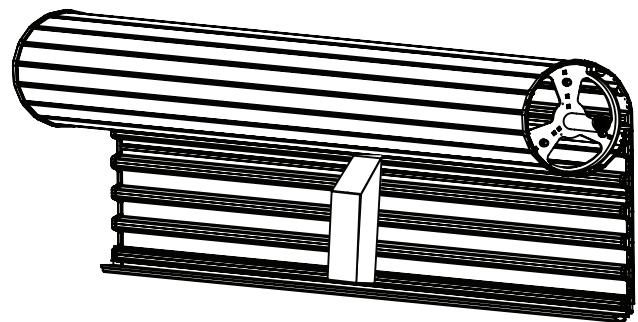

Install Guides

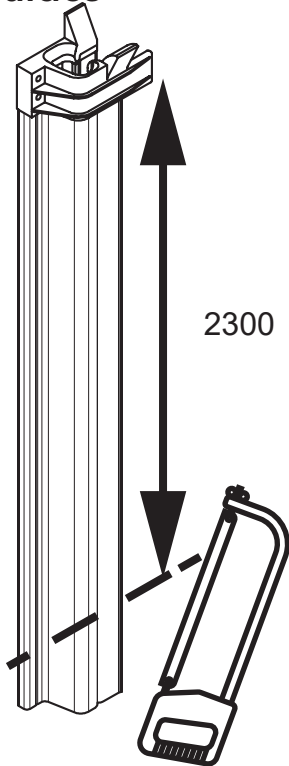

1. Cut tracks to suit opening. Measure and mark 2300 mm from the **UNDERSIDE** of the end cap as shown. Then cut using a hacksaw or angle grinder. Do this for both the Left and Right Guide.

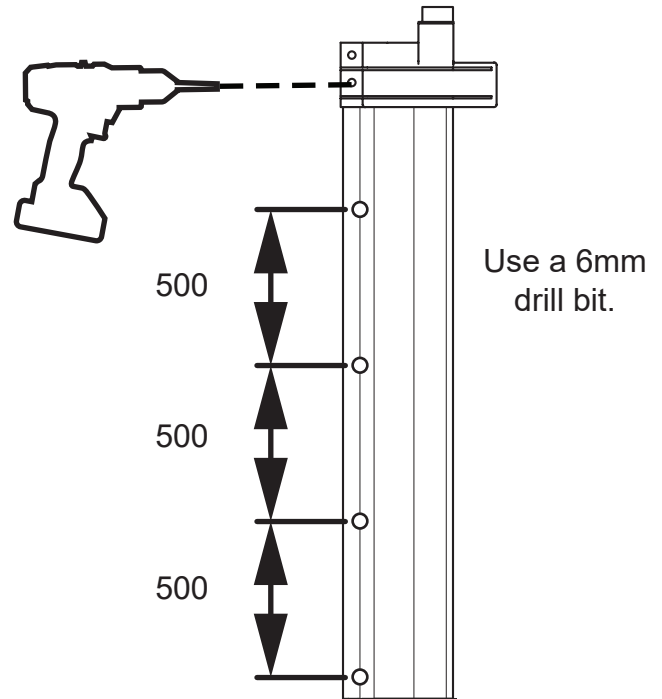

2. Using a 6mm drill bit, pre-drill holes to fix the guides to the framing. Start 25mm from the bottom then measure upward and mark at 500mm increments. Also drill the hole lower hole in the end cap.

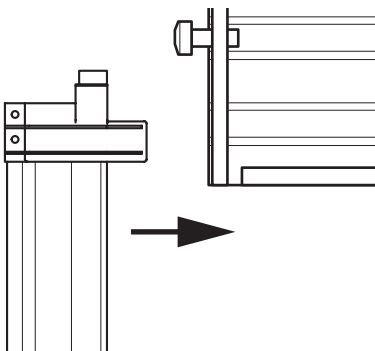

3. Locate the guides over the hanging door. Be careful not to dislodge the wood chock holding the door in position.

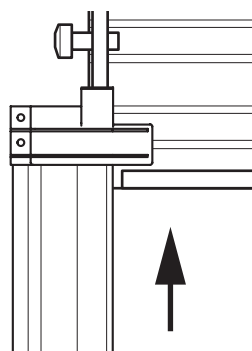

4. Next the guide will have to be moved along the door so the windlock knob slides inside it's specialised channel in the guide.

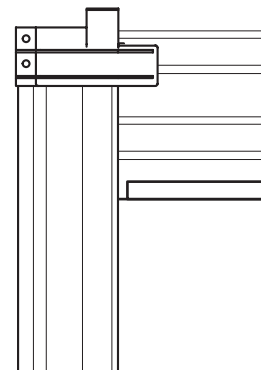

5. Now it is aligned push the bottom of the guide against the frame and work on the other side.

The guide can be slid over the edge of the door before the windlock.

Install Guides - Continued

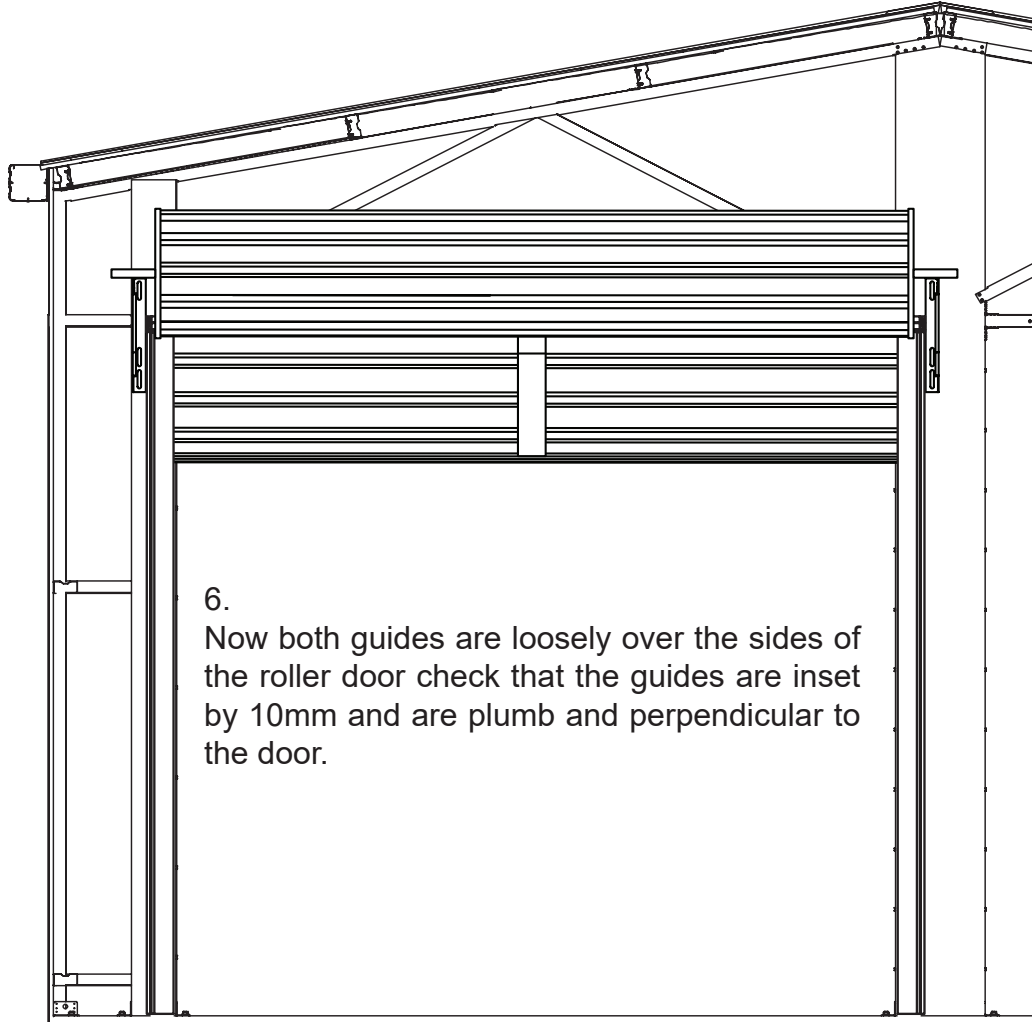

6.
Now both guides are loosely over the sides of the roller door check that the guides are inset by 10mm and are plumb and perpendicular to the door.

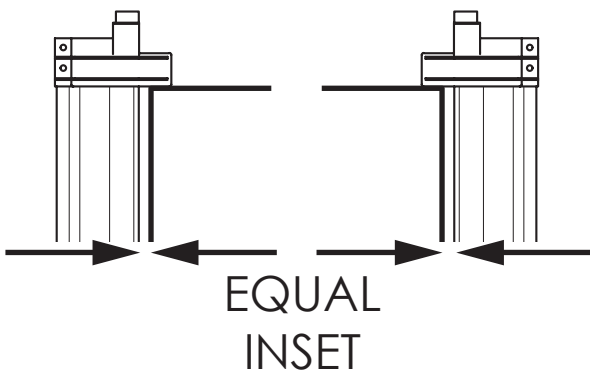

7.
The underside of the end cap protrusion should be level with underside of the header beam. Next fasten the guides with 14G 20TPI Tek screw as described next.

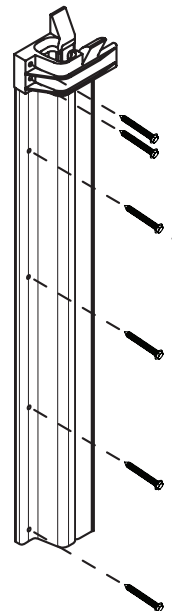

8.
Secure the indicated fixing through the pre-drilled hole of both the left and right guides. Next pull the door all the way down. Taking note if the door catches at any point. If so alter the angle or spacing of the guide until it moves freely.

9.
Apply the rest of the fixings constantly checking door moves freely,

Drill Locking Bar Holes

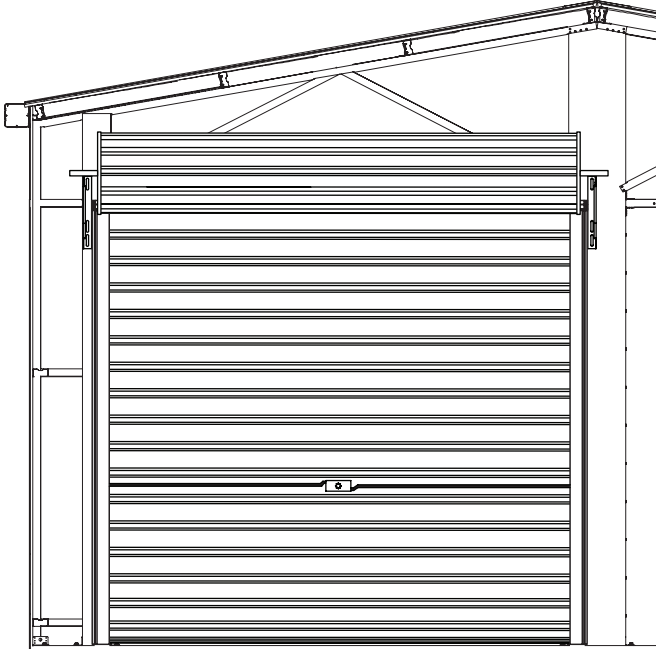

1.
Close the door so that the weather seal compresses onto the floor.
2.
Mark the position of the locking bar inside the left and right guides.
3.
Drill holes on both guides. You will need to make a slot shape so multiple holes will need to be made per side.
4.
Lock the door and adjust hole size with a file to obtain a satisfactory fit between weather seal and floor.

TIP:
Make sure the weather seal compresses onto the floor before marking lock holes.

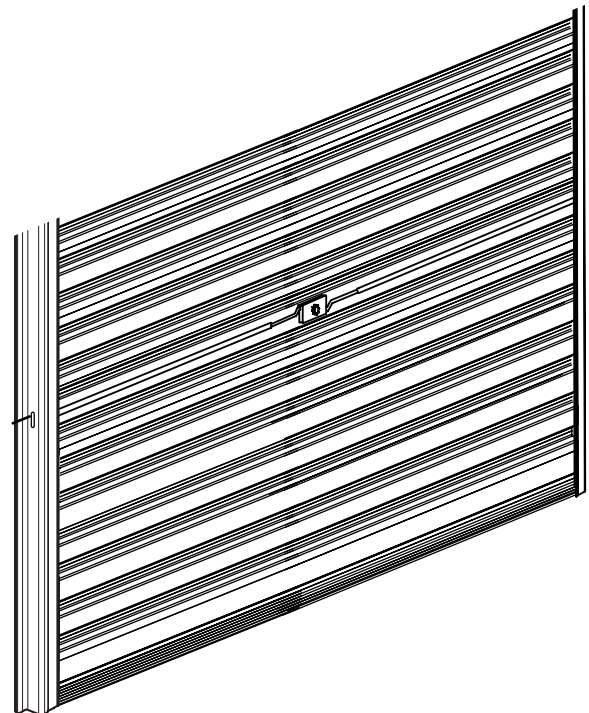

Absco Sheds Storage Guidelines

- Absco Sheds are designed to be weatherproof for normal weather conditions. In the event of extreme weather conditions such as heavy rain, combined with high wind gusts, the ridge capping, sheeting joints, screw fixings etc., may exhibit minor deformations which may allow some water entry. These areas should be checked regularly to ensure that maximum strength and protection is maintained.
- Other weather conditions such as extreme heat and extreme cold, moist or dry air can influence the effects of concrete floor moisture and/or condensation on the underside of the roof sheets.
- Absco Sheds and storage units are primarily used for storage of garden equipment such as lawnmowers, wheelbarrows, garden tools etc. Storage items that might be adversely affected by any of the above conditions may require additional protection such as being sealed or covered by plastic sheets and/or stacked above the concrete floor on timber slats.
- Waterproof sealants may be used to offer further protection where required around joins and screw fixings, as can rubber door seals and other products which are available from most hardware outlets.
- Placement of waterproof sealants (silicone) between the base of the shed and concrete slab is not recommended, as this process can have a reverse effect, preventing excess water from escaping, resulting with water accumulating and being trapped inside the shed.
- Absco accepts no responsibility for water entry, floor moisture, condensation or the condition of the Contents inside your Absco steel building arising from any of the pre-mentioned weather conditions.
- Absco accepts no responsibility for structural damage if doors were left open and/or not secured during a weather event.

Lifetime Warranty Statement



1. DEFINITIONS

In this document, capitalised terms have the following meaning:

- (a) "ABSCO" means John Scholtes Investments (No. 1) Pty Ltd trading as Absco Industries.
- (b) "Authorised Purpose" means for storage (other than storage of corrosive materials), and other activities typically expected of a non-habitable structure.
- (c) "Defect" means a defect in the design, workmanship, materials, or any other defect caused by the manufacturing process of the Product (including damaged or missing parts).
- (d) "Excluded Environment" means land located within 1km of:
 - (i) salt marine locations or other areas of marine influence;
 - (ii) severe industrial or other abnormally or highly corrosive environments;
 - (iii) areas not washed by rain;
 - (iv) a recognised flood, bushfire or earthquake zone; or
 - (v) areas with uncontrolled fill, unless an engineered foundation is constructed.
- (e) "Lifetime Warranty Period" means the period of 35 years, commencing on the day after the date of purchase of the Product.
- (f) "Lifetime Warranty Statement" means this 'Lifetime Warranty Statement' document.
- (g) "Parties" means ABSCO and You.
- (h) "Product" means any of following unless stated otherwise in the product description and/or the Product Guide for the Product:
 - (i) products which utilise ABSCO 'SNAP-TITE' technology, including but not limited to garden sheds, chicken coops, bike sheds and bin covers; and
 - (ii) all non-insulated large structures such as carports, awnings, shades and garages,but does not include any product stated to be in the "ABSCO Economy" range.
- (i) "Product Guide" means the guide for installation and maintenance of the Product produced by ABSCO.
- (j) "You" / "Your" means the customer who purchased or installed the Product, or the person who owns the land upon which the Product is installed but does not include a subsequent purchaser of the Product where the Product is moved to a different location to that originally installed.

2. ABSCO'S STRUCTURAL WARRANTY

- 2.1. ABSCO provides this warranty to You in relation to the Product. The warranty applies to all colours and finish variants of the Product manufactured by ABSCO and sold by authorised sellers of the Product in Australia or New Zealand.
- 2.2. Subject to the terms of this Lifetime Warranty Statement:
 - (a) ABSCO warrants that the Product will be free from Defects for the duration of the Lifetime Warranty Period; and
 - (b) where the Product contains a Defect, ABSCO will either repair or replace the Product, or provide You with monetary compensation for the Defect in accordance with clause 3.

3. WARRANTY CLAIM PROCEDURE

- 3.1. If, during the Lifetime Warranty Period, You believe the Product has a Defect, You must comply with the procedure set out in this clause 3.
- 3.2. Within 30 days of becoming aware of the Defect in the Product, You must notify ABSCO in writing of the alleged Defect ("Defect Notice") by email to admin@absco.com.au.
- 3.3. The Defect Notice must include:
 - (a) Your name, address and contact details;
 - (b) proof of purchase of the Product, including the colour and finish of the Product;
 - (c) the date and location of the installation of the Product and details of the contractor or installer of the Product;
 - (d) details of the alleged Defect in the Product, including but not limited to:
 - (i) a clear description of the alleged Defect;
 - (ii) the date the alleged Defect was first identified; and
 - (iii) any photographs and/or video footage of the alleged Defect.
- 3.4. As soon as reasonably practicable after receipt of the Defect Notice, ABSCO will contact You to investigate the alleged Defect. You must make the Product available to ABSCO and/or its authorised representatives for inspection and testing if so required.
- 3.5. A travel fee may apply if ABSCO and/or its authorised representatives are required to inspect the Product outside a capital metropolitan city area.
- 3.6. If ABSCO's investigations reveal a genuine Defect in the Product, ABSCO may elect to either:
 - (a) repair the Product;
 - (b) replace all or part of the Product; or
 - (c) refund all or part of the purchase price paid by You as compensation for the Defect in the Product.
- 3.7. ABSCO's election in clause 3.6 is at ABSCO's sole discretion.
- 3.8. If ABSCO elects to repair the Product, ABSCO will arrange for a qualified tradesperson to attend to the rectification of the Defect as soon as reasonably practicable. The cost of the repair will be borne by ABSCO.
- 3.9. If ABSCO elects to replace the Product:
 - (a) ABSCO will arrange for the replacement Product to be available for collection by You from the nearest ABSCO authorised reseller as soon as reasonably practicable;
 - (b) You may be required to return the alleged Defective parts or components to ABSCO; and
 - (c) You will be liable for the cost of disassembly and removal of the Product and assembly of the replacement Product.
- 3.10. If ABSCO elects to repair or replace the Product and the necessary parts or components are no longer manufactured or supplied by ABSCO, ABSCO may repair or replace the parts or components with parts or components of a similar quality, grade, composition and colour. You cannot object to such an alternative.
- 3.11. If ABSCO's investigations do not reveal a genuine Defect in the Product (including a defect which is not covered by this warranty), You agree to pay ABSCO's reasonable investigation costs.

4. WARRANTY LIMITATIONS / EXCLUSIONS

4.1. To the extent permitted by law, this warranty will not apply where:

- (a) the Product has been installed or used for a purpose that is not an Authorised Purpose;
- (b) the Product has not been installed, assembled, maintained and/or operated in complete compliance with ABSCO's Product Guide;
- (c) the Product has been used to store corrosive materials such as fertiliser or chlorine;
- (d) the Product was installed in excess of 12 months after the purchase of the Product;
- (e) the Product has not been installed in accordance with the relevant standards, codes and statutory regulations;
- (f) the Defect is determined to have been caused by storm, wind, rain, earthquake, fire, snow or poor foundations;
- (g) the Defect is, or is the result of, surface deterioration of panels caused by 'swarf' (tiny particles of steel debris left from cutting, grinding or drilling operations);
- (h) the Product has been installed in an Excluded Environment;
- (i) the Product has been subject to accident, negligence, alteration, abuse or misuse;
- (j) the Defect is determined to be the result of overloading; or
- (k) ABSCO determines that the Defect is the result of a failure of a third-party product.

4.2. You acknowledge that:

- (a) dimensions and colour of the Product are subject to normal manufacturing variations and tolerances, and that reasonable variances are not considered a Defect under this warranty; and
- (b) this warranty is limited to the repair or replacement of Defects in the Product and does not extend to any other product or any other consequential or indirect damage incurred as a result of the Defect.

4.3. For the purpose of this warranty, the following matters are excluded from the definition of Defect:

- (a) general wear and tear which is reasonably expected to occur over the life of the Product;
- (b) surface deterioration of panels caused by 'swarf' (tiny particles of steel debris left from cutting, grinding or drilling operations);
- (c) condensation caused by weather conditions such as extreme heat or cold;
- (d) defects in any fastening apparatus (screws, nuts, bolts, rivets, hasps or bolts);
- (e) leaks caused by driving rain;
- (f) improper installation, maintenance or handling of the Product;
- (g) movement, distortion, collapse or settling of the ground or the supporting structure on which the Product is installed; or
- (h) staining from foreign substances (including mould, mildew, dirt, grease, oil and any other substance).

4.4. To the extent permitted by law, ABSCO is not liable to compensate You for any:

- (a) increased costs or expenses;
- (b) loss of profit, revenue, business, contracts or anticipated savings;
- (c) loss or expense resulting from a claim by a third-party; or

- (d) special, indirect or consequential loss or damage of any nature whatsoever, arising from a Defect in the Product or ABSCO's repair or replacement of the Product under this warranty.

5. CONSUMER LAW

Australian Consumer Law

5.1. Clauses 5.2 to 5.3 apply where the Product was purchased in Australia.

5.2. The Product comes with guarantees that cannot be excluded under the Australian Consumer Law. You may be entitled to a replacement or refund for a major failure of the Product and compensation for any other reasonably foreseeable loss or damage. You may also be entitled to have the Product repaired or replaced if the Product fails to be of acceptable quality and the failure does not amount to a major failure.

5.3. The benefits of this Lifetime Warranty Statement are in addition to any rights and remedies imposed by Australian State and Federal legislation that cannot be excluded. Nothing in this Lifetime Warranty Statement is to be interpreted as excluding, restricting or modifying any State or Federal legislation applicable to the supply of goods and services which cannot be excluded, restricted or modified.

New Zealand Consumer Law

5.4. Clauses 5.5 to 5.6 apply where the Product was purchased in New Zealand.

5.5. This warranty is subject to the laws of New Zealand, including but not limited to the New Zealand Sale of Goods Act, the Consumer Guarantees Act and the Fair Trading Act.

5.6. The benefits of this Lifetime Warranty Statement are in addition to any rights and remedies imposed by New Zealand legislation that cannot be excluded. Nothing in this Lifetime Warranty Statement is to be interpreted as excluding, restricting or modifying any New Zealand legislation applicable to the supply of goods and services which cannot be excluded, restricted or modified.

6. NO REPRESENTATIONS / ENTIRE AGREEMENT

6.1. You agree and acknowledge that this Lifetime Warranty Statement contains the entire agreement between the Parties regarding the warranty provided by ABSCO to You in relation to the Product.

6.2. To the full extent permitted by law, this Lifetime Warranty Statement supersedes all other warranties of any kind, including whether express or implied by representations, statement, correspondence or other conditions such as merchantability or fitness for purpose.

7. REGISTRATION OF WARRANTY

7.1. Please ensure that You keep this Lifetime Warranty Statement in a safe place along with your proof of purchase of the Product.

7.2. To ensure ABSCO has a record of your warranty, You can register Your warranty online at <http://absco sheds.com.au/warranty-details/>.