



# CHICKEN COOP MODEL: AOGC15081HC

1.52mW x 0.78mD x 1.80mH

📞 AU: 1800 029 70  
NZ: 0800 466 444

✉️ admin@absco.com.au  
www.abscosheds.com.au

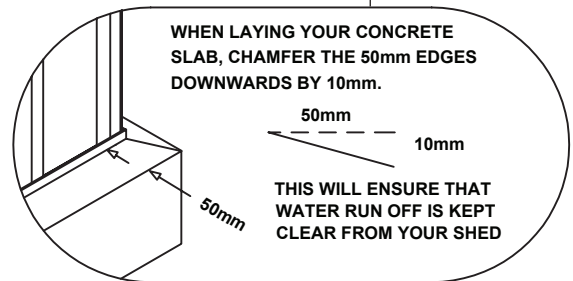
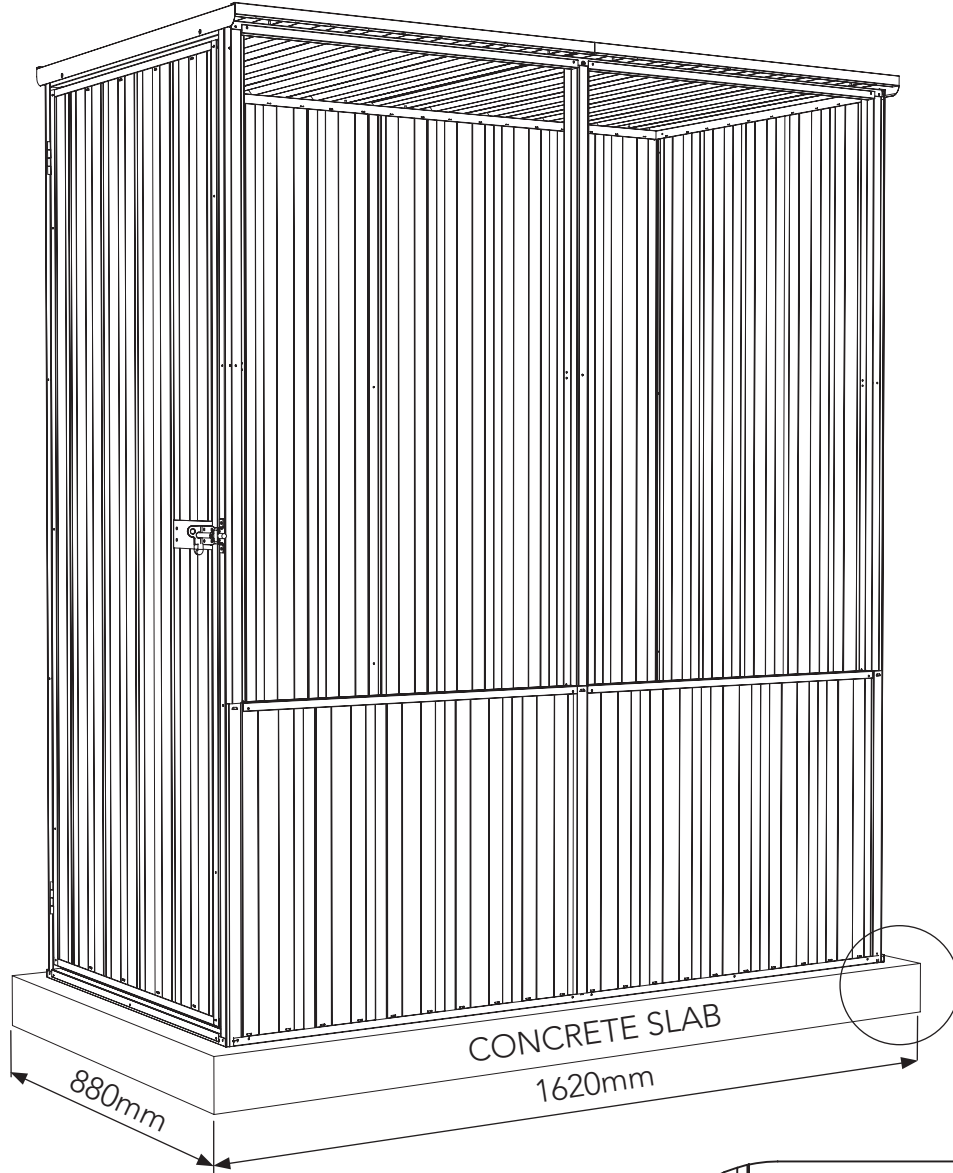

**DOWNLOAD  
OUR APP FOR  
ASSEMBLY  
VIDEOS**



## PLEASE LEAVE A REVIEW

Tell us about your experience!  
Visit [www.abscosheds.com.au/review](http://www.abscosheds.com.au/review)



# CHICKEN COOP MODEL: AOGC15081HC

1.52mW x 0.78mD x 1.80mH

## GENERAL INSTRUCTIONS

- Before commencing any assembly, read through these instructions in detail to gain a thorough understanding of assembly methods and associated details.
- Unpack the carton and carefully identify and check off all the parts against the parts described and illustrated on "COMPONENTS PACKING LIST" pages.

## SITE PREPARATION

- The site for the shed must be level. An uneven surface may result in misalignment of parts.
- The shed shall be erected on top of a reinforced concrete slab and anchored down appropriately illustrated on "FINAL CONSTRUCTION" page.

## TOOLS REQUIRED



## SAFETY NOTES

- Some parts may have sharp edges. It is advisable to wear gloves when handling these items and safety glasses if drilling holes. Sensible shoes are highly recommended.
- Do not erect your shed in windy conditions.
- Ensure that the shed is securely anchored to a solid foundation immediately after construction is completed.
- It is highly recommended to erect the shed with two or more people.
- Do not sit, stand or walk on the roof of your shed.
- **WARNING:** It is recommended that new galvanized mesh should be weathered for two (2) months or scrubbed with a mild acidic solution, such as vinegar, then rinsed with water before being used in bird housing applications.

## RECOMMENDED









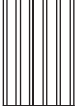
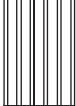
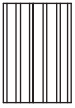
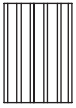
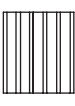
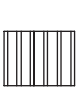
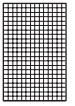
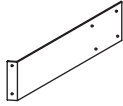

# CHICKEN COOP MODEL: AOGC15081HC

1.52mW x 0.78mD x 1.80mH

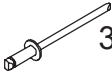
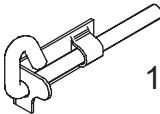
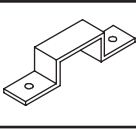
## COMPONENT PACKING LIST

Check off all components.

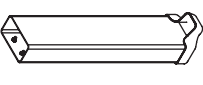
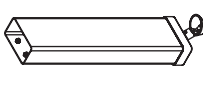
SHEETING							
QTY	COMPONENT DESCRIPTION	PART No.	CHK	QTY	COMPONENT DESCRIPTION	PART No.	CHK
1	 STEEL SHEET 1785 x 773mm	30A		1	 STEEL SHEET 1785 x 773mm	30E	
1	 STEEL SHEET 1785 x 773mm	30G		1	 STEEL SHEET 1725 x 711mm	37A	
2	 STEEL SHEET 845 x 773mm	44V		2	 STEEL SHEET 600 x 773mm	31D	
2	 MESH SHEET 1195 x 705mm	MESH20					
INSTRUCTIONS AND FITTINGS PACKET							
1	 DOOR PLATE	12A		15	 8G x 3/4" SELF TAPPING SCREW	FAST013	
6	 3mm POP RIVET	FAST009		1	INSTRUCTION MANUAL	IM	
1	 PADBOLT 115mm LONG	FAST006		1	 PADBOLT HASP	FAST007	
1	 8G x 3/8" SELF TAPPING SCREW PACK QTY 220	FAST001 PACK220		1	 PHILLIPS HD DRIVER BIT	FAST038	
1	 3mm DRILL BIT	DRILL		6	 3/16 x 1/2" CSK SCREW & NUT	FAST004 FAST005	
HUNGRY CHOOKS							
1	 FEEDER KIT	HCFEEDER KIT		1	 DRINKER KIT	HCDRINKER KIT	





Nominal sheet widths are shown. +/- 2mm is within tolerance.

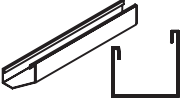
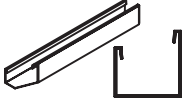
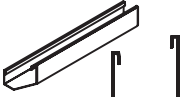
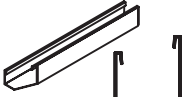
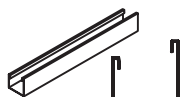
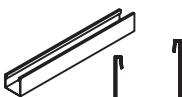
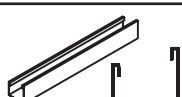
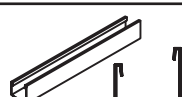
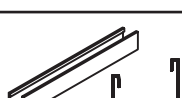

# CHICKEN COOP MODEL: AOGC15081HC

1.52mW x 0.78mD x 1.80mH

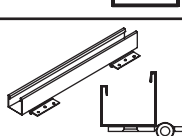
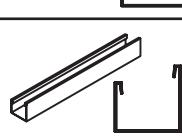
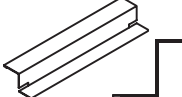
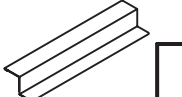
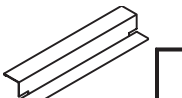
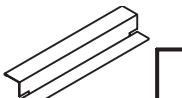
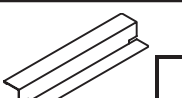
Check off all components.

CHANNEL PACK							
QTY	COMPONENT DESCRIPTION	PART No.	CHK	QTY	COMPONENT DESCRIPTION	PART No.	CHK
3	 CHANNEL 1785mm	<b>80L</b>		1	 CHANNEL 1513mm	<b>81F</b>	
1	 CHANNEL 1513mm	<b>53C</b>		2	 CHANNEL 1488mm	<b>53T</b>	
4	 CHANNEL 712mm	<b>181</b>		3	 CHANNEL 766mm	<b>139</b>	
1	 CHANNEL 773mm	<b>185</b>		2	 CHANNEL 1513mm	<b>81E</b>	
2	 CHANNEL 712mm	<b>58M</b>		1	 CHANNEL 720mm	<b>54G</b>	
1	 CHANNEL W/ HINGES 1725mm	<b>58A</b>		1	 CHANNEL 1725mm	<b>58B</b>	
1	 JAMB 1785mm	<b>89A</b>		1	 JAMB 1785mm	<b>89B</b>	
4	 JAMB 1785mm	<b>70D</b>		1	 JAMB 720mm	<b>91D</b>	
2	 JAMB 1080mm	<b>91E</b>		2	 LIP TRIM 847mm	<b>88Y</b>	



# CHICKEN COOP MODEL: AOGC15081HC

1.52mW x 0.78mD x 1.80mH

## SNAPTITE ASSEMBLY GUIDE

The Snaptite Assembly System locks end channels to all roof and wall sheets without the need for tools and fasteners.

To assemble each panel, the perimeter channels are secured to the top and bottom of each panel. Gently tap the channel over the SNAPTITE lugs on the sheet, working along the sheet.

Each perimeter channel must finish flush with the edges of the sheets. Simply tap the channel along the sheets until each end is neatly flush. If you need to remove channels from the panels, slide it off from the side.

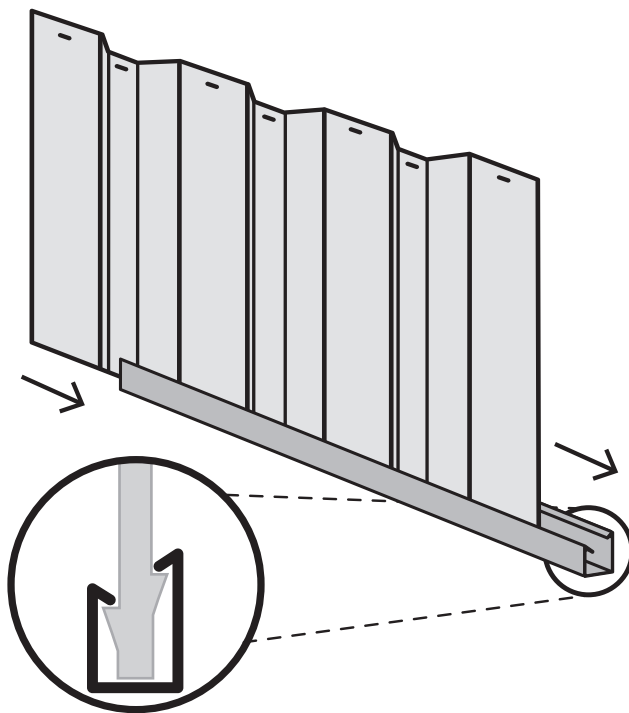

# SNAPTITE

World's Easiest Assembly System  
*UNIQUE PATENTED SYSTEM*

Channel locks the shed panel into position without the need for screws!

### FASTENING SYMBOLS



Secure channel to sheeting by SNAPTITE fastening method.



Join components together with one screw at this location only, as some channels have extra holes that are not required for this model of shed.

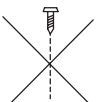

Do not join components together at this location yet, as the screws may obstruct further assembly of the other components.



Join components together by pre-drilling the holes first. Use one component as template to mark where the holes are and drill with a 3mm drill bit.



3mm pop rivet



4mm nut and bolt set.

## ROOF AND WALL OVERVIEW

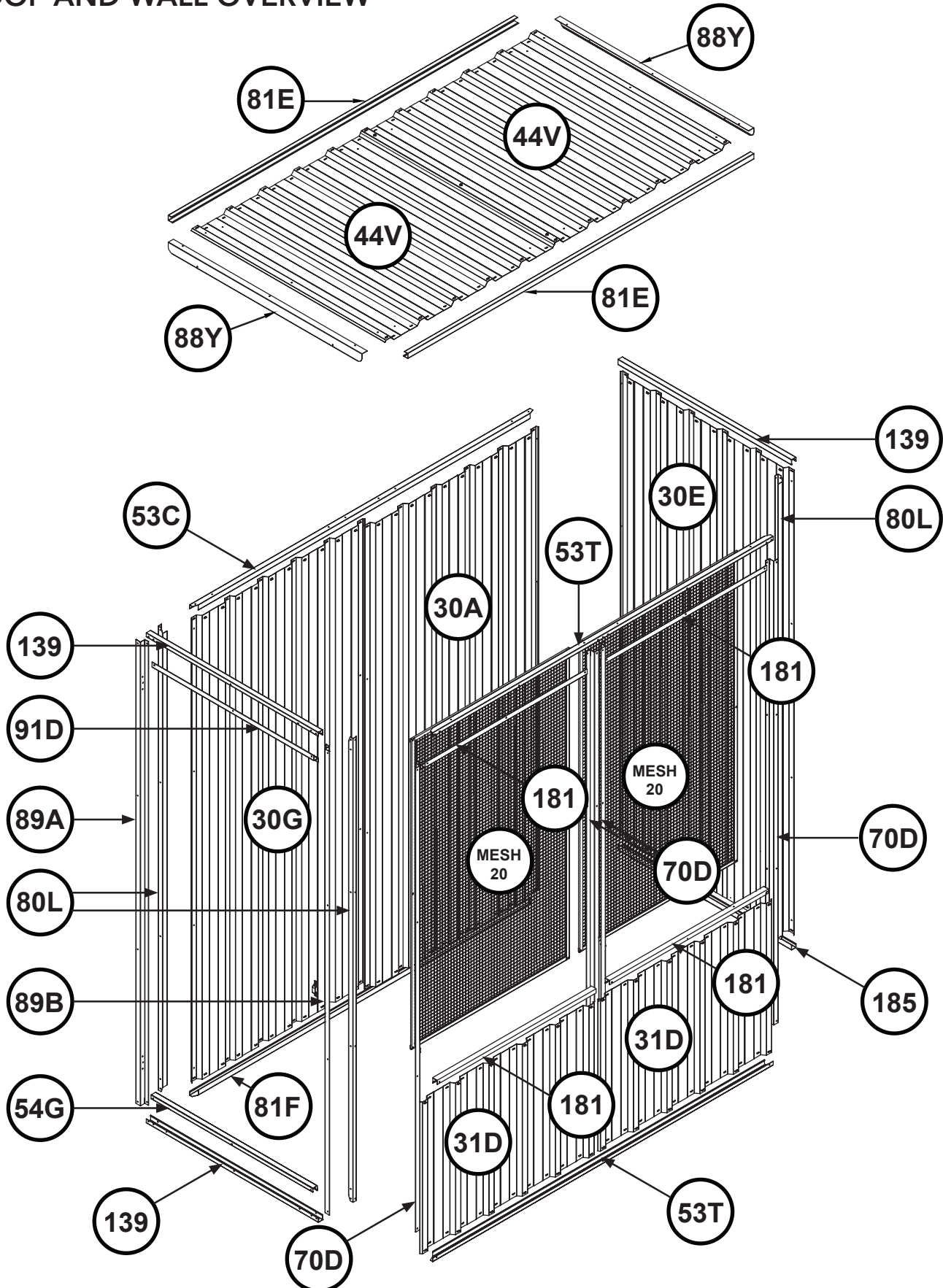

### ROOF PANEL ASSEMBLY

1x required

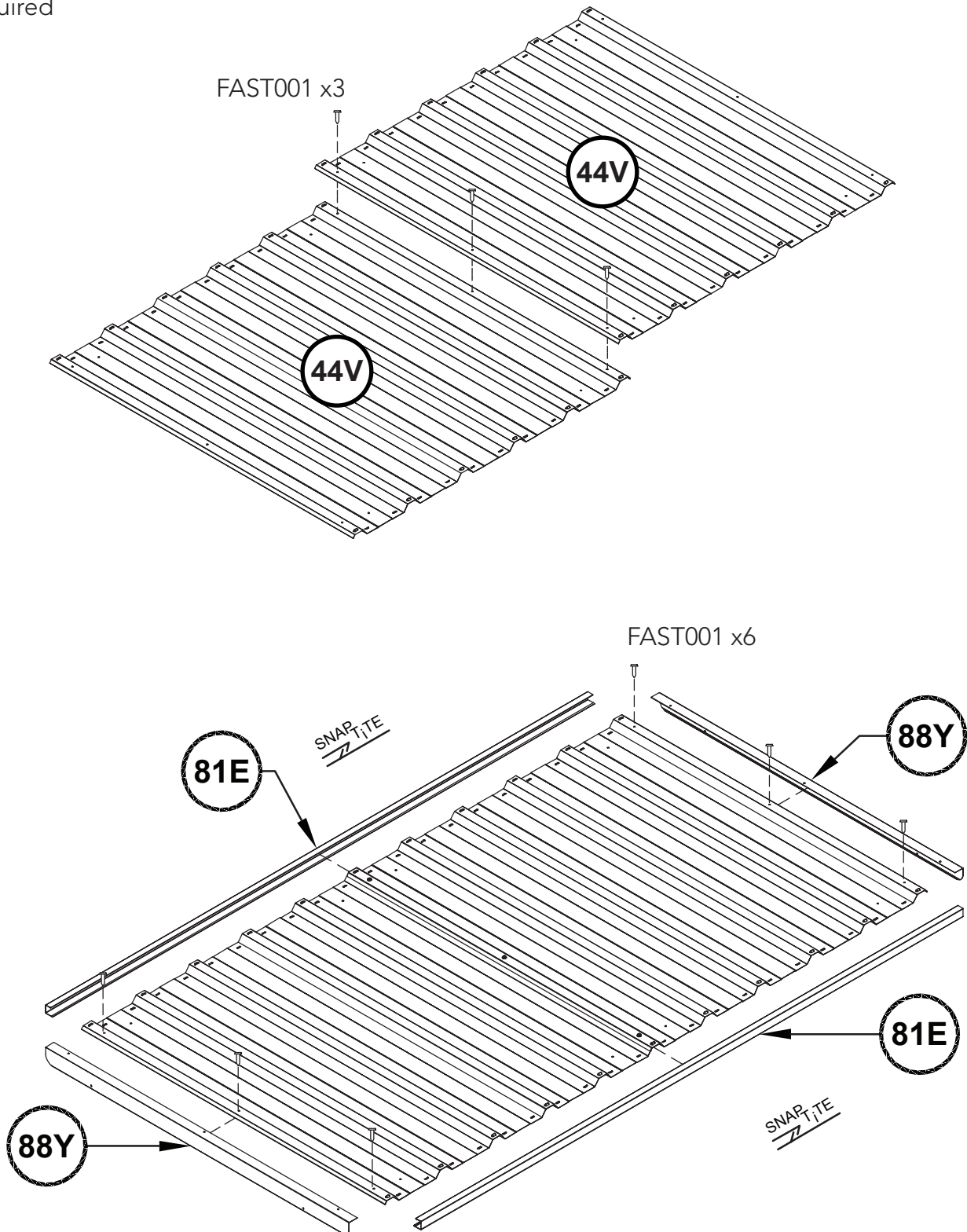

## RIGHT SIDE PANEL ASSEMBLY

1x required

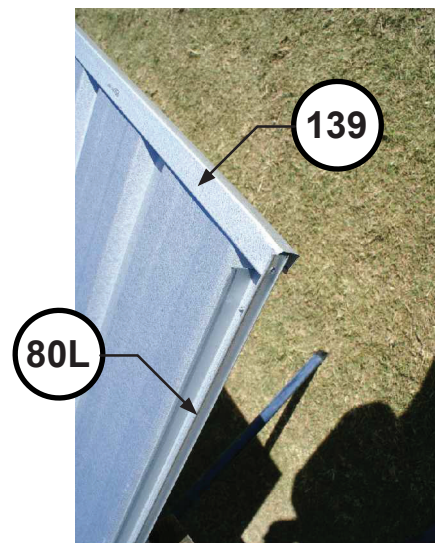
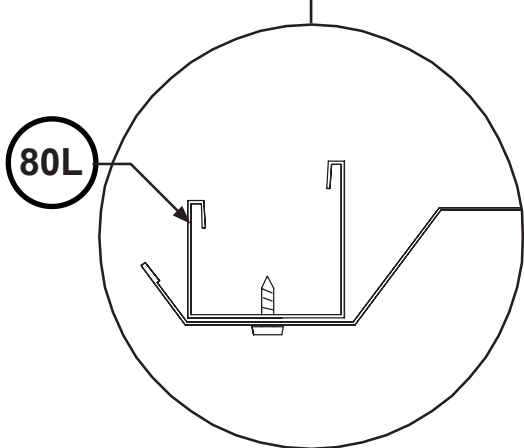
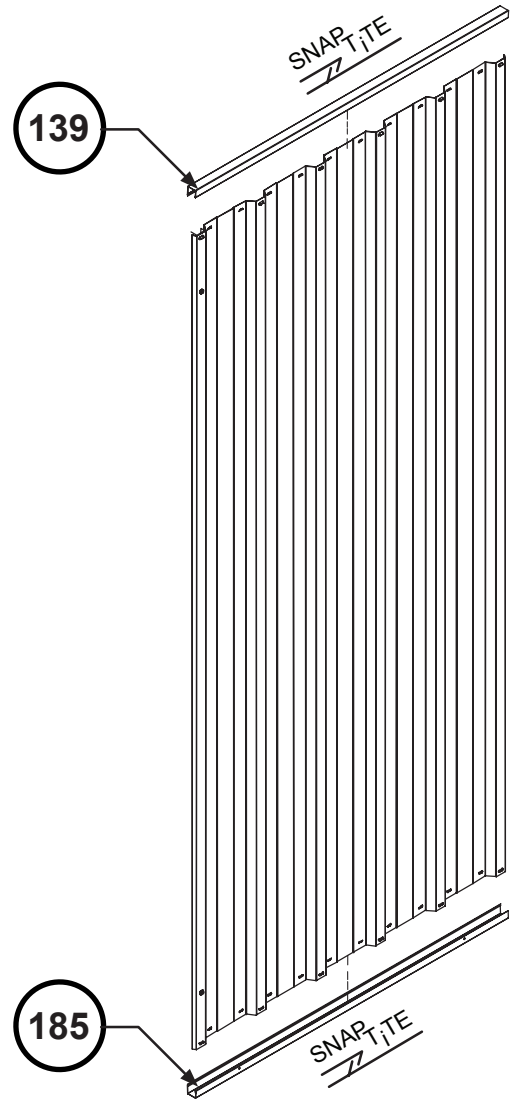
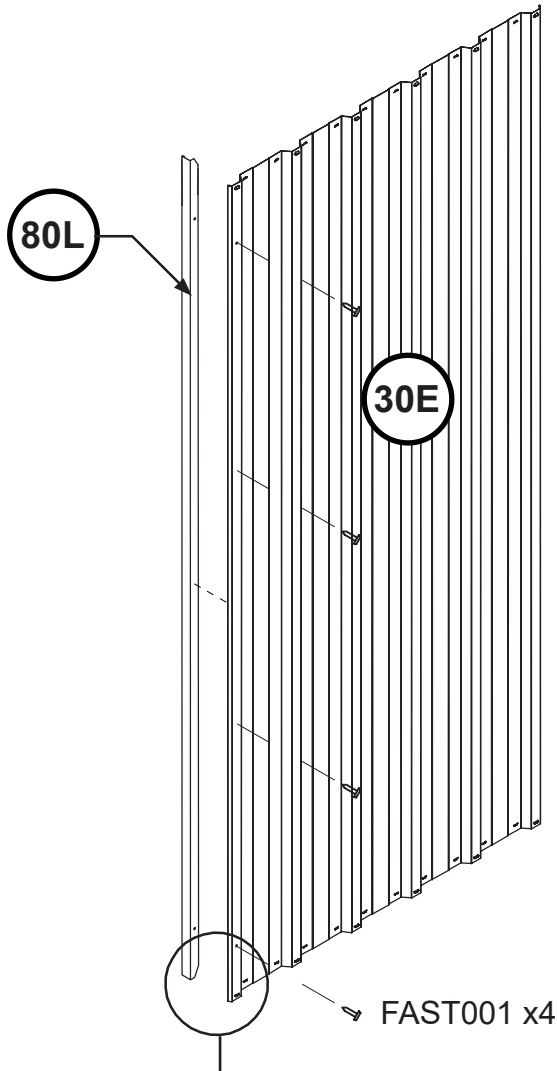

Inside view of 80L and 139



# CHICKEN COOP MODEL: AOGC15081HC

1.52mW x 0.78mD x 1.80mH

## DOOR PANEL ASSEMBLY

1x required

FAST001 x12

Narrow pan of sheet  
to this side

SNAP  
TITE

58M

Position 12A  
midway along the  
door.

58A

12A

37A

58B

58M

SNAP  
TITE

Side channels of door  
are to be orientated  
opposite to top and  
bottom channels.

20mm flange

15mm flange

FAST001 x4

FAST006

Side channels are  
positioned behind top  
and bottom channel.

# CHICKEN COOP MODEL: AOGC15081HC

1.52mW x 0.78mD x 1.80mH

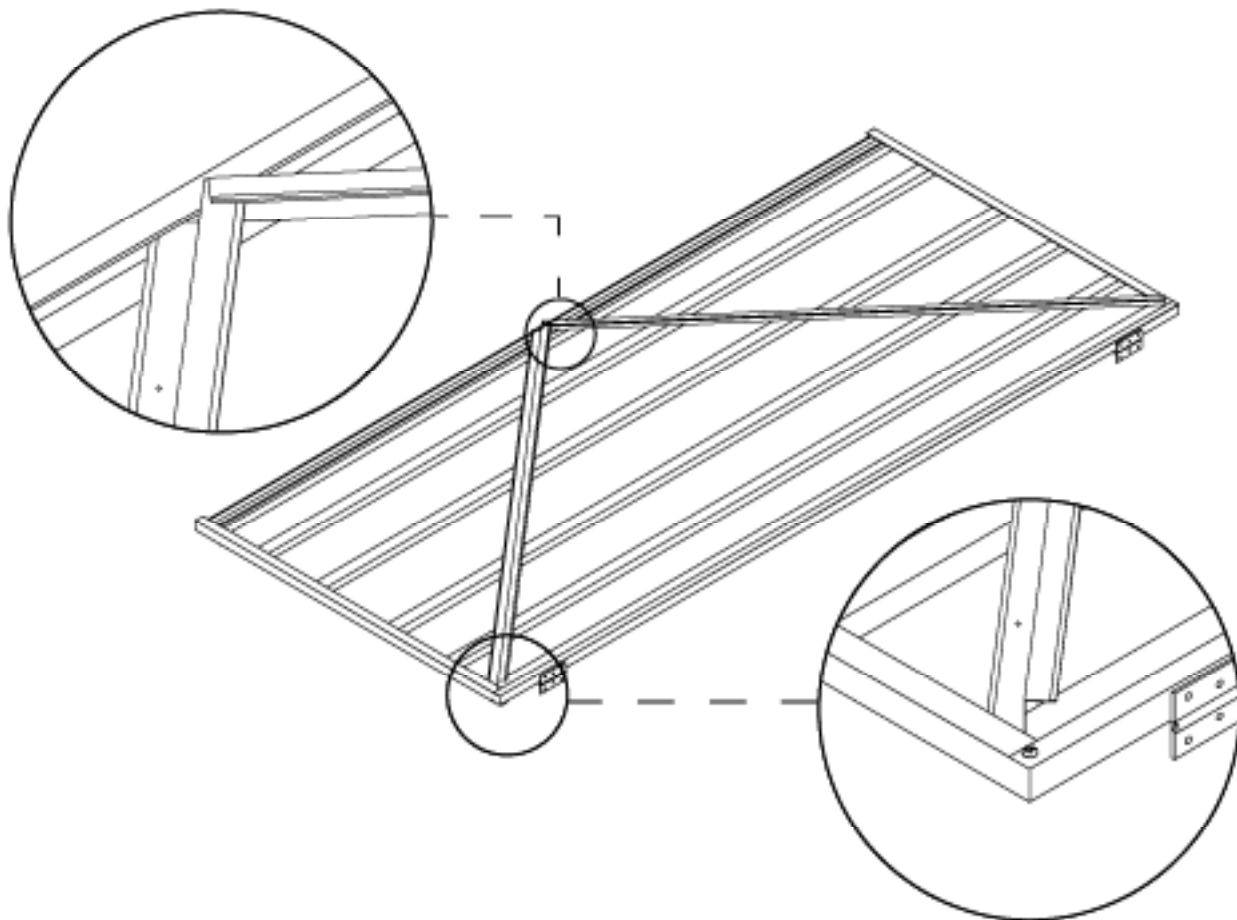
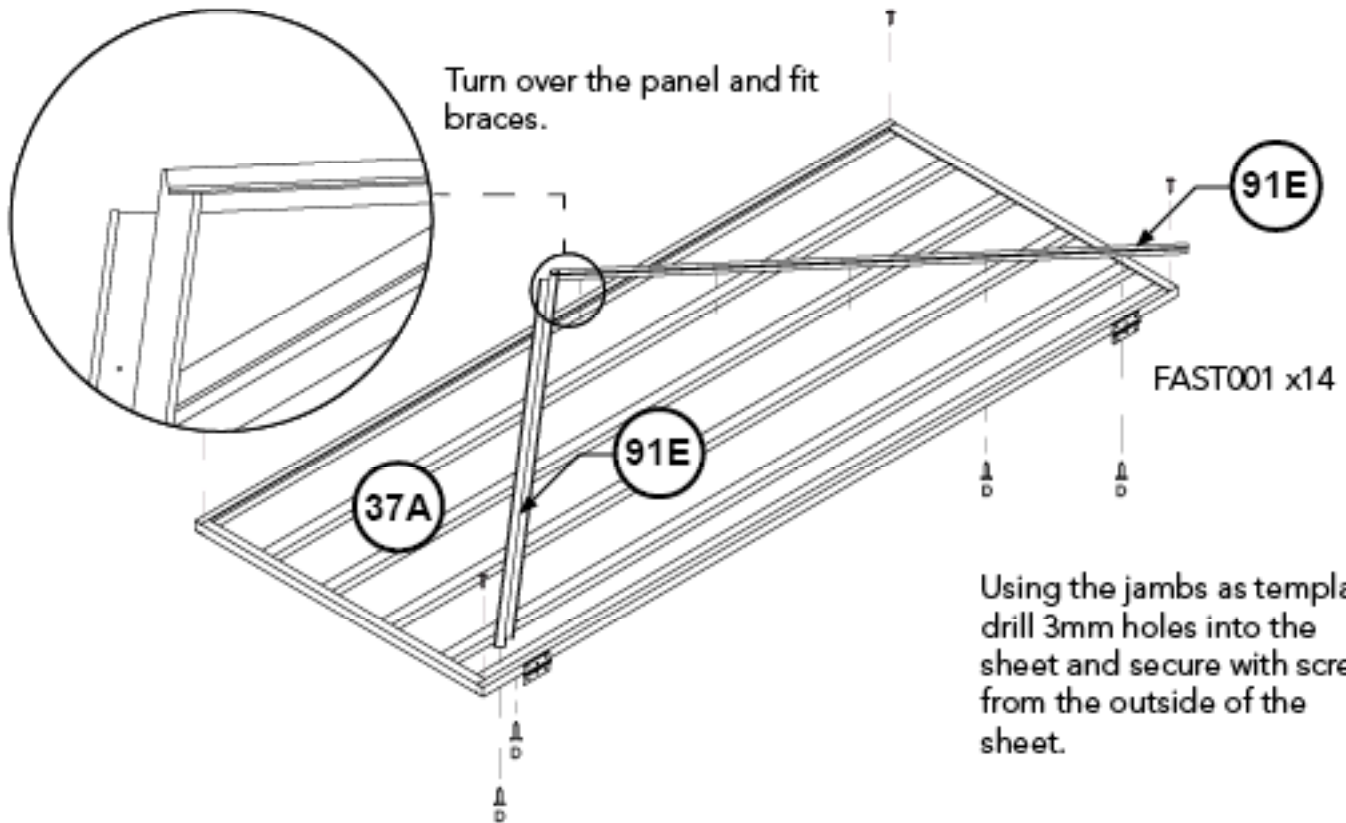

**LEFT SIDE PANEL ASSEMBLY**

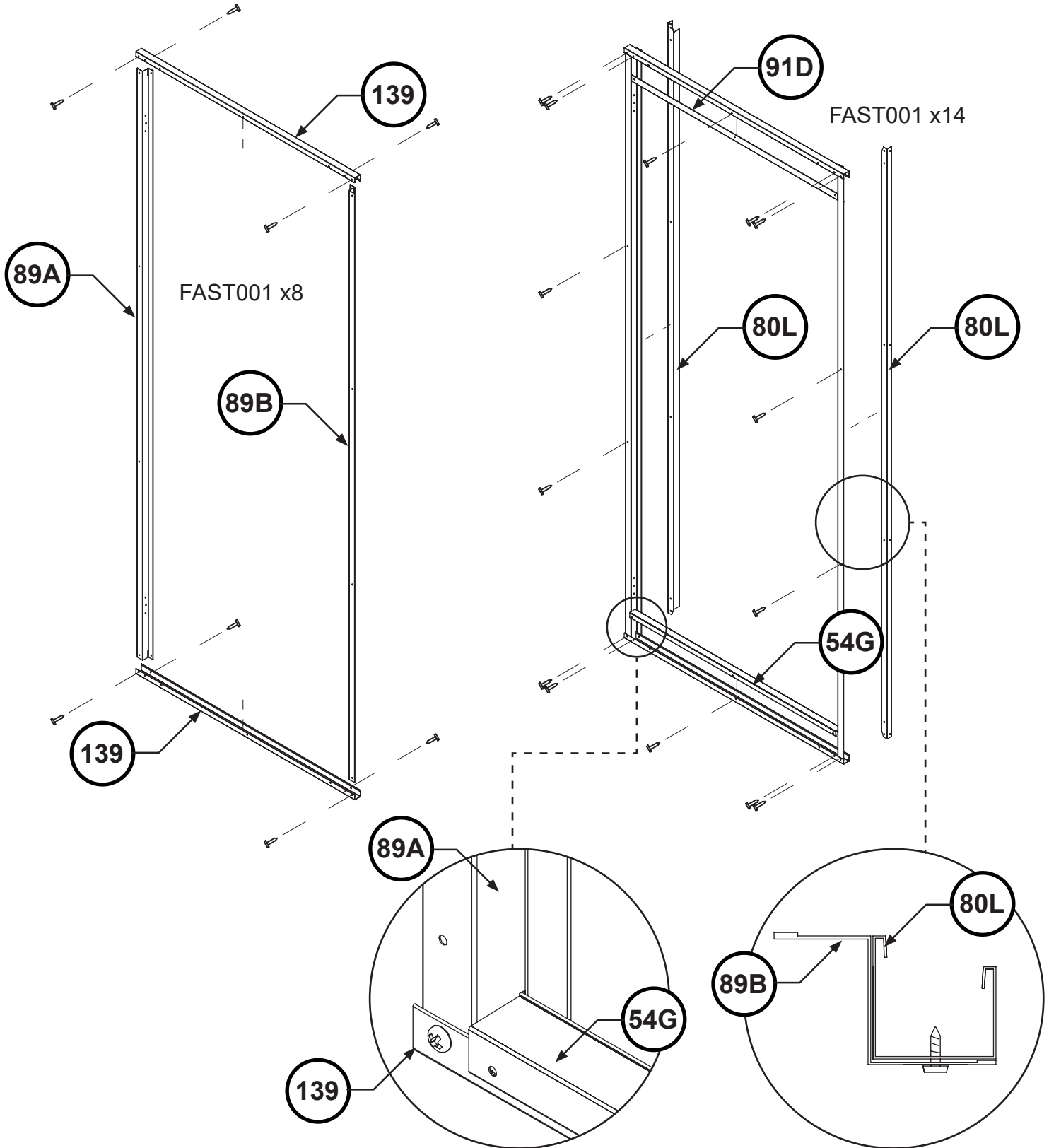

## DOOR PANEL ASSEMBLY

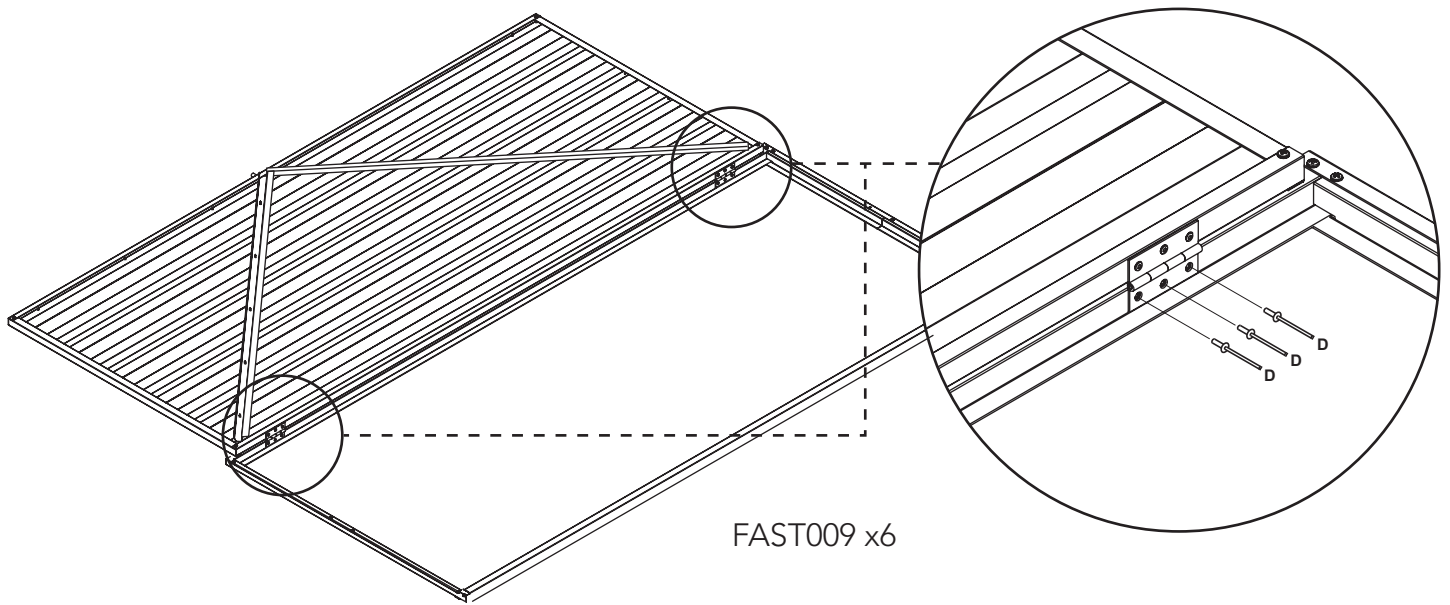

Lay the LEFT SIDE PANEL face up and lay the DOOR PANEL down in the open position on top as shown.

Using three rivets per hinge, FAST009, secure the door to the frame.

NOTE: Run the 3mm drill bit through the punched holes in the jamb before riveting the hinge on.

## REAR PANEL ASSEMBLY

1x required

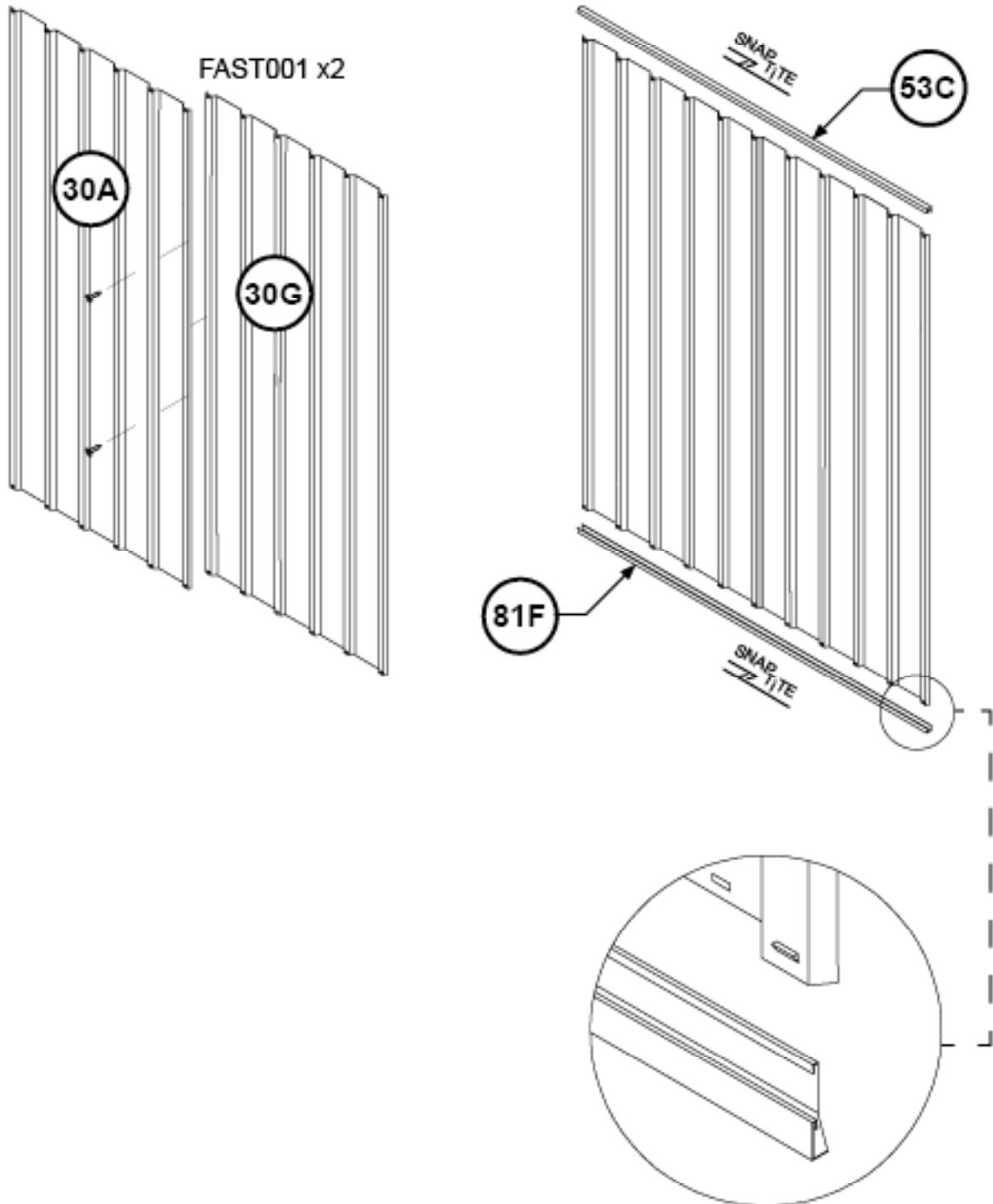

# CHICKEN COOP MODEL: AOGC15081HC

1.52mW x 0.78mD x 1.80mH

## FRONT PANEL

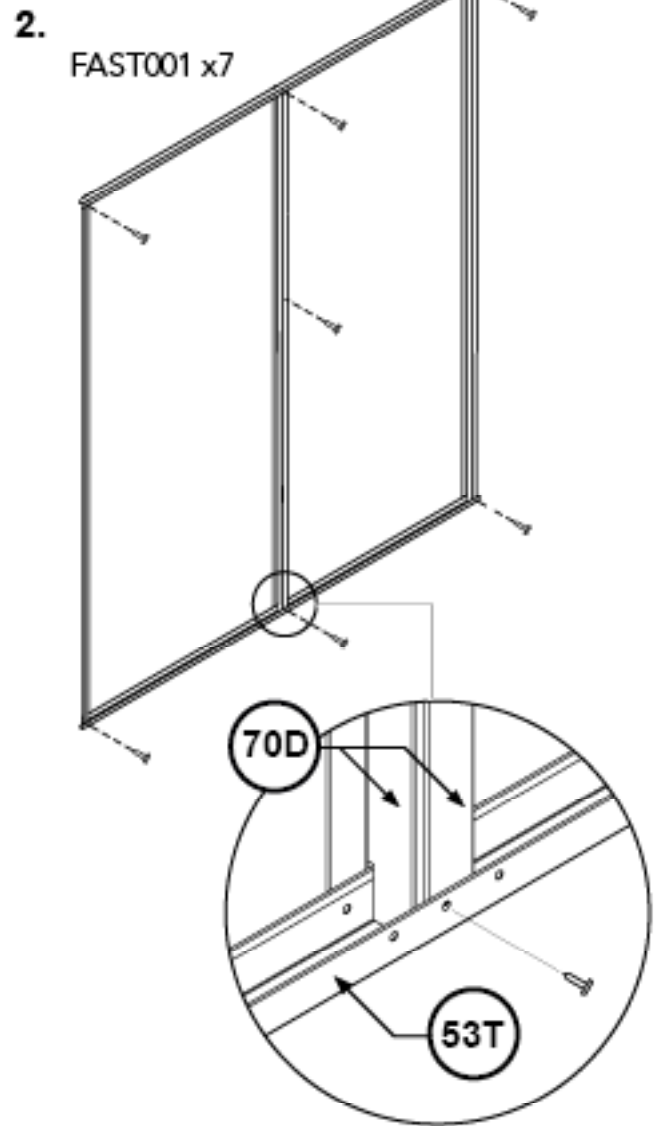
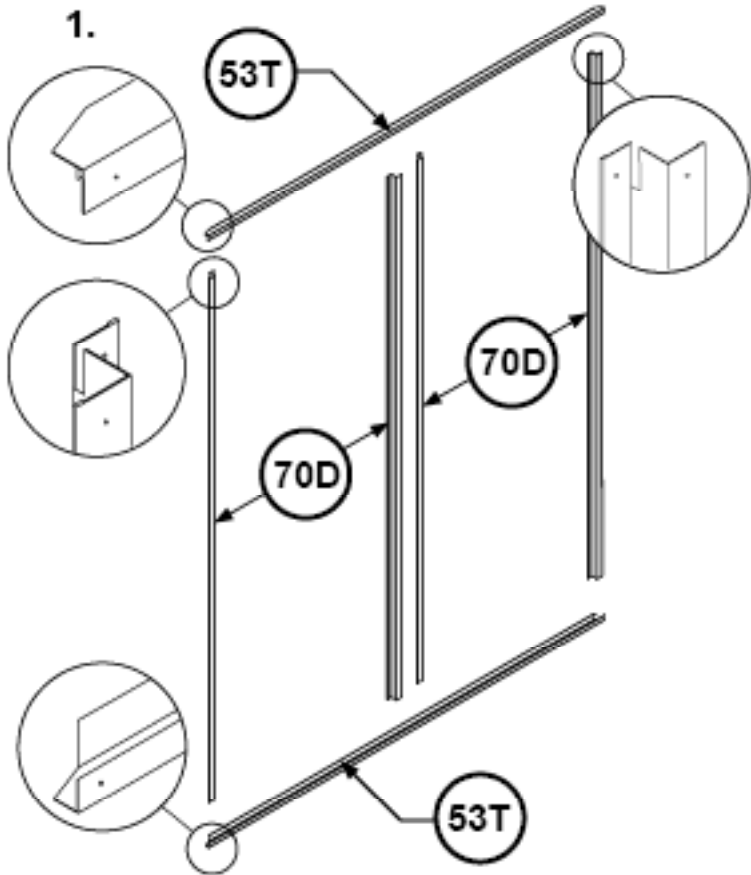

3.  
Prepare two  
short sheets

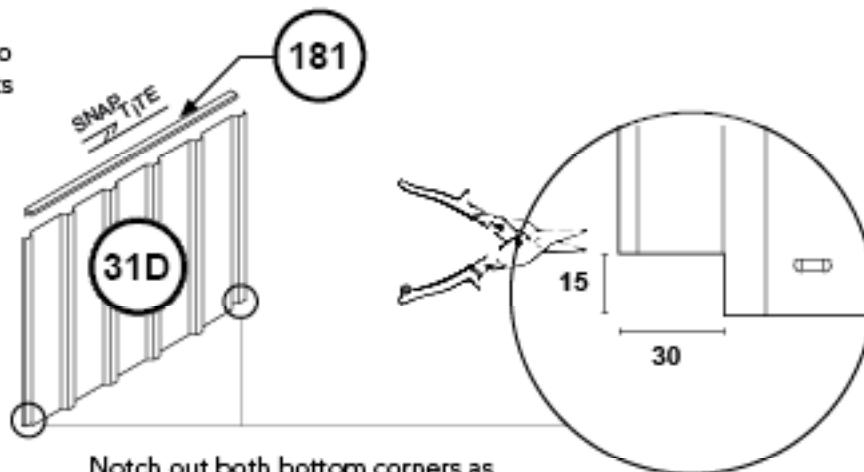

Notch out both bottom corners as shown using tinsnips.

# CHICKEN COOP MODEL: AOGC15081HC

1.52mW x 0.78mD x 1.80mH

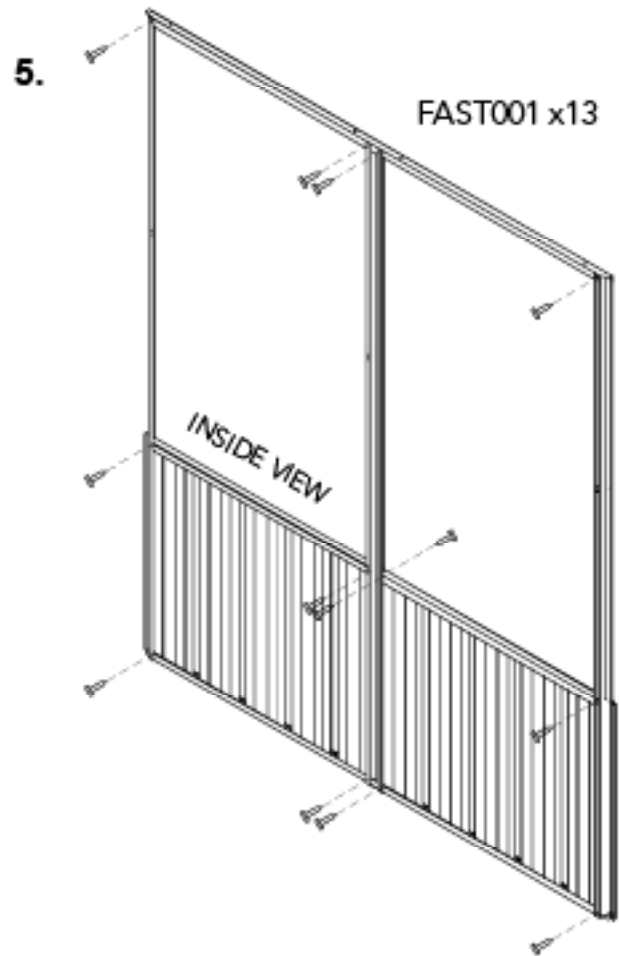
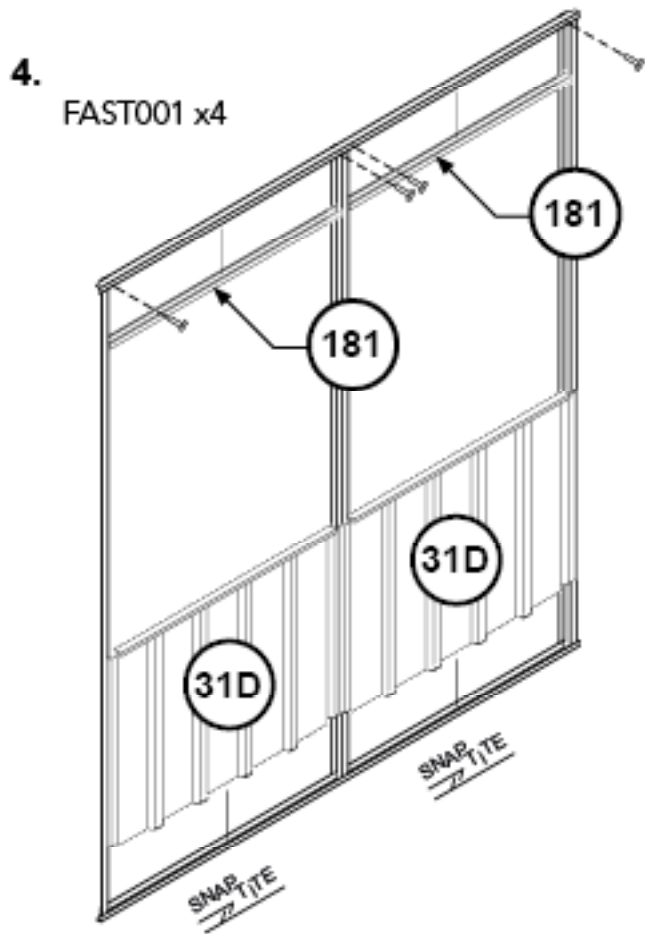

### FITTING MESH PANELS

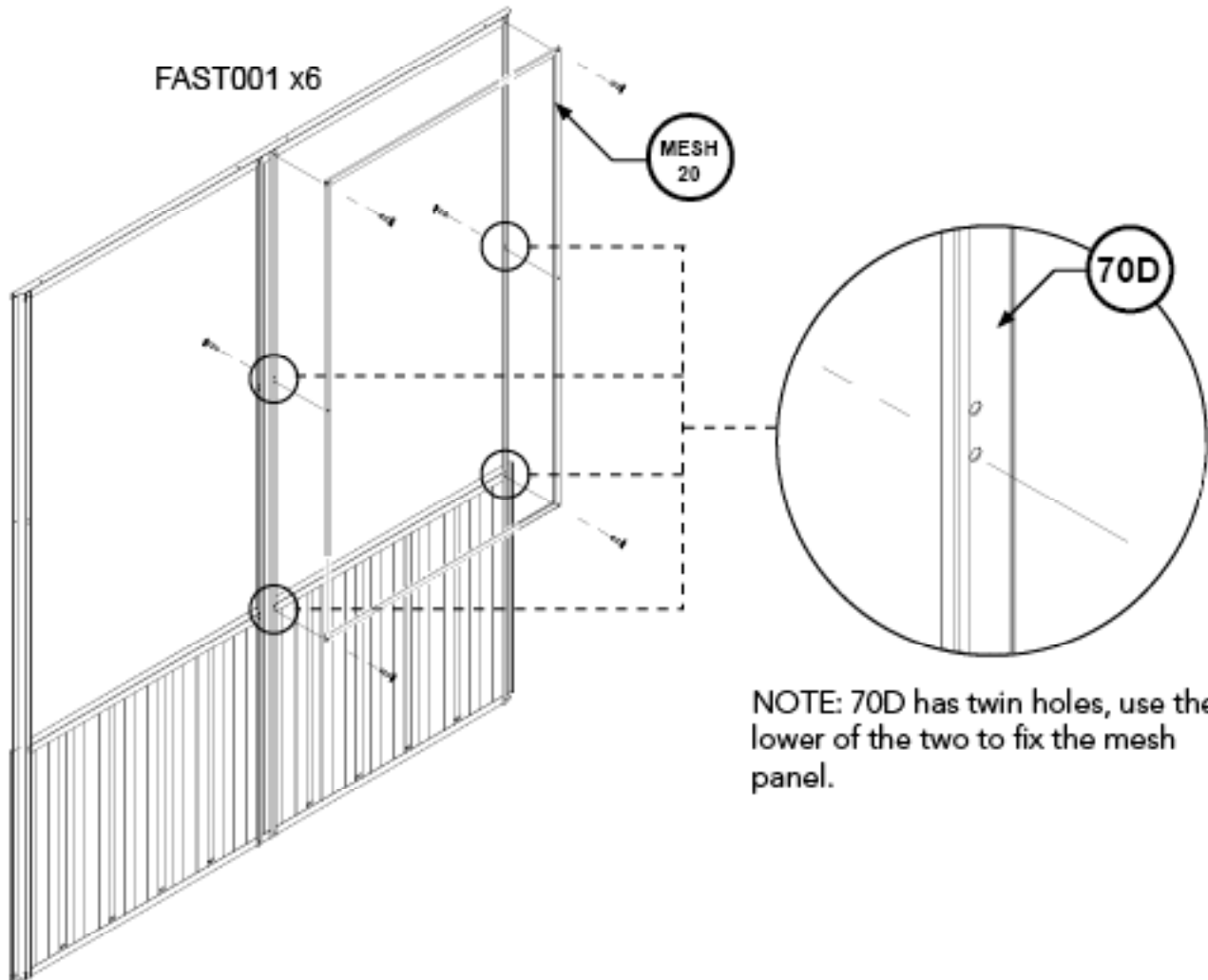

NOTE: 70D has twin holes, use the lower of the two to fix the mesh panel.

The mesh panels are fixed to the interior of the wall panels.

There are six holes in the border of the mesh panel, these align with holes in the vertical jambs 70D in the wall panel and are fixed with FAST001 screws.

The top and bottom FAST001 are to be screwed from the inside of the panel.

The middle two are to be done from the exterior.

If the panel is bowing out between screws use additional fixings. Be sure to predrill with a 3mm drill bit before using additional FAST001 screws.

Repeat this for every mesh position.

**WARNING:** It is recommended that new galvanised mesh should be weathered for two (2) months or scrubbed with a mild acidic solution, such as vinegar, then rinsed with water before being used in bird housing applications.



## PANEL CONSTRUCTION

NOTE: Take care to ensure that all wall panels are not upside down. The top channels of each panel are pre-punched for attaching roof sheeting. The base channels are not pre-punched.

Mesh panels are not shown for illustrative purposes.

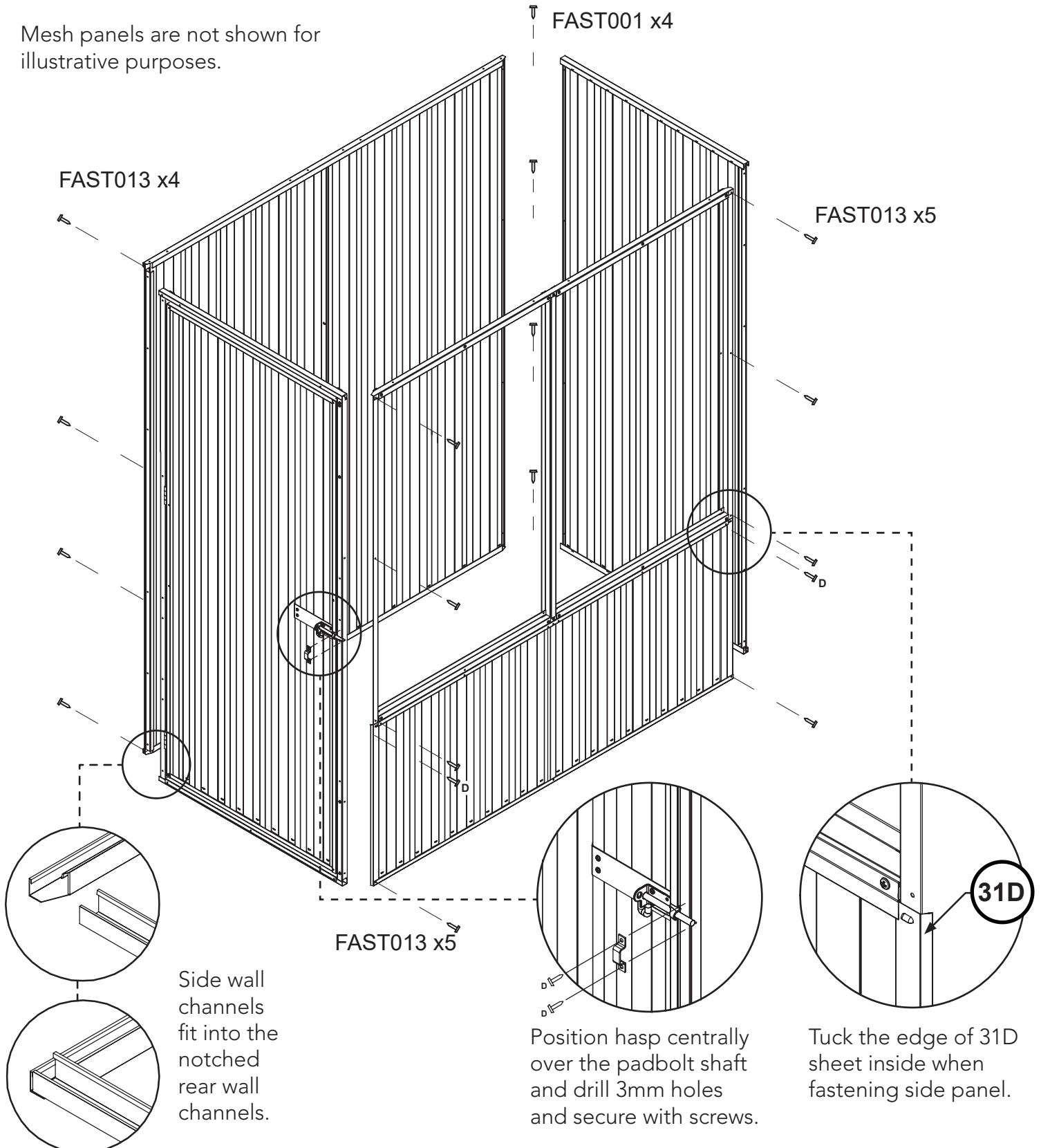

### FINAL CONSTRUCTION

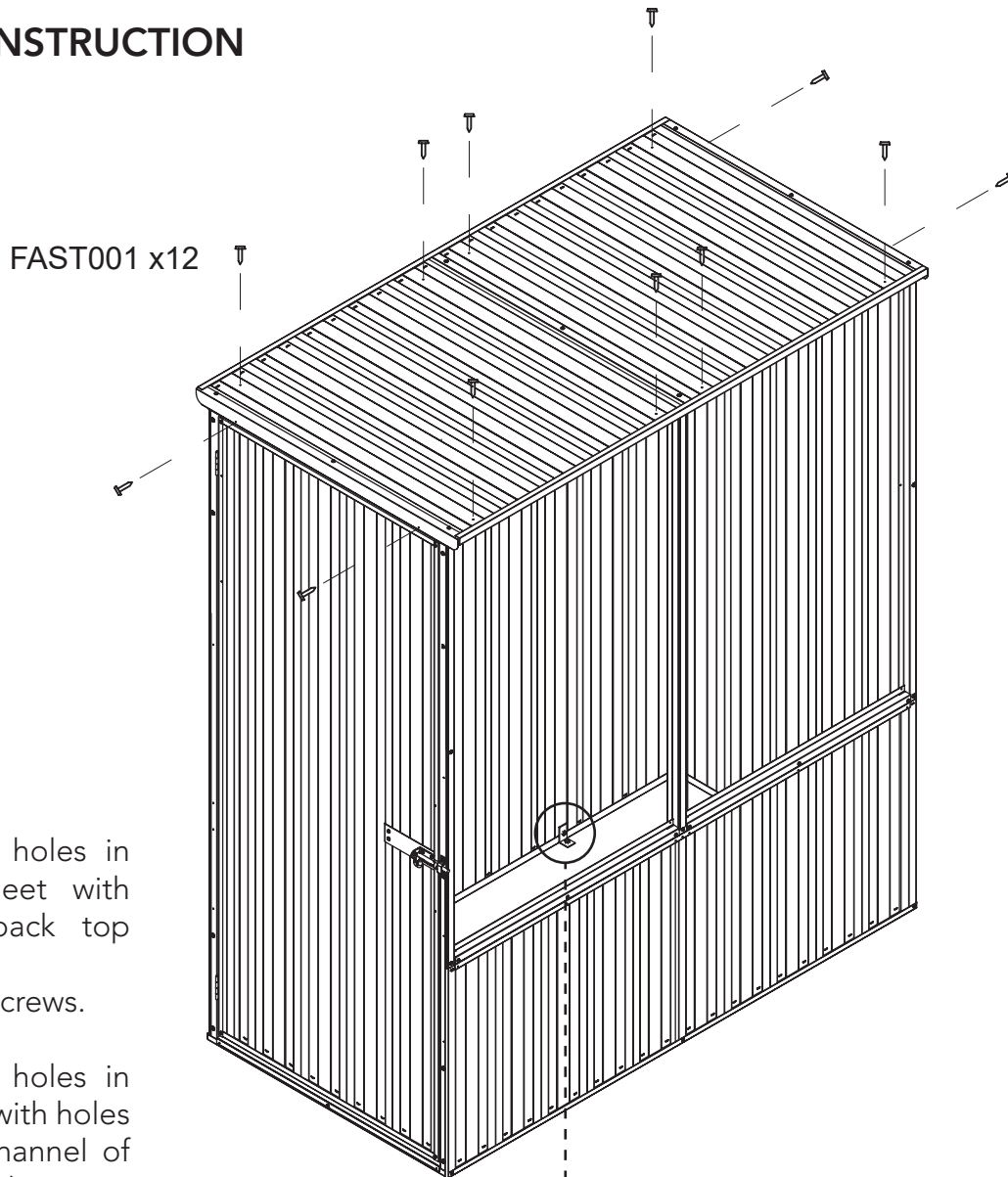

Line up the holes in the roof sheet with front and back top channels. Secure with screws.

Line up the holes in the roof lips with holes in the top channel of the side panels. Secure with screws.

#### ANCHORING OF COOP

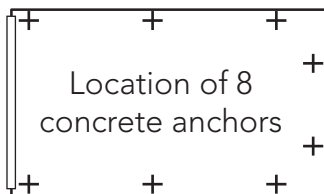



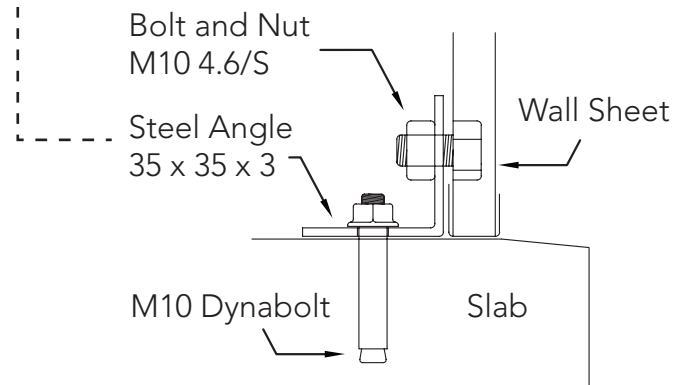





Each anchor consists of one nut, bolt, M10 dynabolt and steel angle. Drill a 10mm hole into the wall sheet. Drill a 10mm hole into the concrete.



# HUNGRY CHOOKS











## CHICKEN FEEDER - PARTS

QTY	DESCRIPTION	No.	CHK	QTY	DESCRIPTION	No.	CHK
1	 FEEDER END CAP	HC01		1	 PIPE	RWG19	
1	 END CAP	HC02		1	 SADDLE	FAST007	
4	 BOLT	FAST002		4	 NUT	FAST005	
2	 HOOK	FAST078		2	 WASHER	FAST077	

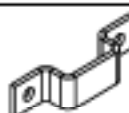

## CHICKEN DRINKER - PARTS

QTY	DESCRIPTION	No.	CHK	QTY	DESCRIPTION	No.	CHK
2	 DRINKER END CAP	HC02		1	 DRINKER CUP	HC03	
1	 PIPE	RWG19		2	 WASHER	FAST077	
1	 SADDLE	FAST007		4	 BOLT	FAST002	
4	 NUT	FAST005		2	 HOOK	FAST078	

## ASSEMBLY STEPS

### 1 - Attach the top loop

For both feeder and drinker

#### REQUIRES:

RWG19 - Pipe (x1)  
FAST007 - Saddle (x1)  
FAST002 - Bolt (x2)  
FAST005 - Nut (x2)  
6mm drill bit

Centre the saddle on the widest face of the pipe, 15mm from one end as shown.

Using the saddle as a template mark both hole positions on the pipe and drill using a 6mm bit.

Fasten with a nut and bolt through each hole.

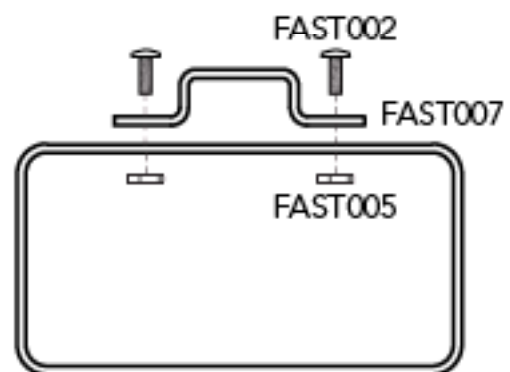
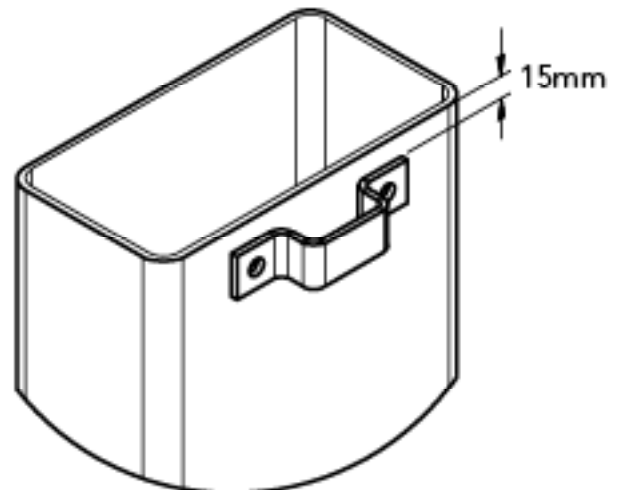

### 2 - Attach the end cap

For both feeder and drinker

#### REQUIRES:

RWG19 - Pipe (x1)  
HC01 or HC02 - Feeder or Drinker (x1)  
Silicone joint sealer and applicator

Orientate the endcap so that its loop is on the same side of the pipe as the top loop fitted in the previous step.

A watertight seal is required for the drinker unit. To do this a silicone joint sealer is required to bond the endcap to the pipe body. Select one that is non-toxic and follow the instructions to achieve the best result.

Apply the sealer to the outside of the pipe, no higher than 20mm from the end, press into end cap and let set.

TIP: Have a cloth handy to clean up any silicone that may ooze out.

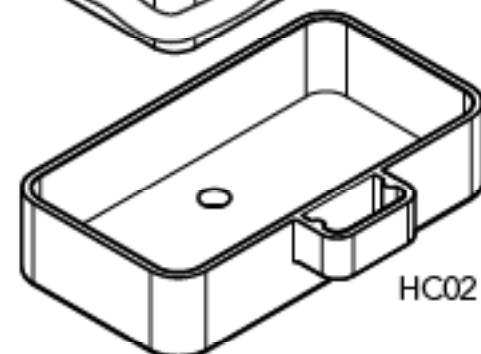
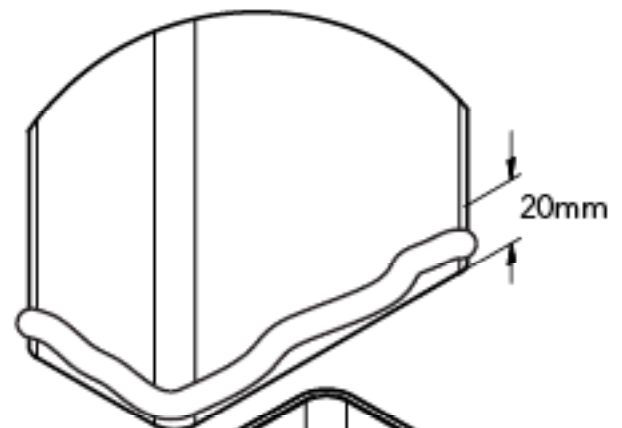

Drinker end cap is shown

### 3 - Fit the cup

For drinker only

REQUIRES:

Drinker unit (x1)

HC03 - Drinker cup (x1)

Make sure that the threaded part of the cup is pointing up. If it isn't unclip the black valve and reorientate so it looks like the figure on the right.

The cup has a self-tapping thread, it is to be screwed into the hole in the bottom of the drinker in the same way you would tighten a screw (turn clockwise).

Align it straight into the hole and turn slowly.

Stop turning when the cup is pointing outward in the forward position.

Be sure to clean up the unit from any debris made by the assembly process before use.

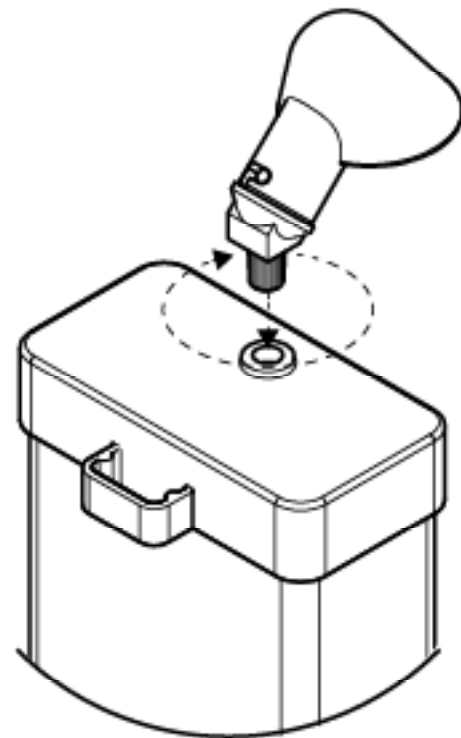
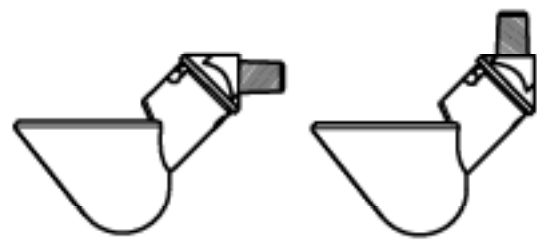

### 4 - Finish it off with a cap

For both feeder and drinker

REQUIRES:

Drinker unit (x2)

Take the remaining end caps and simply put onto the top to stop vermin getting into the feed!

Orientate so the loop is to the front.

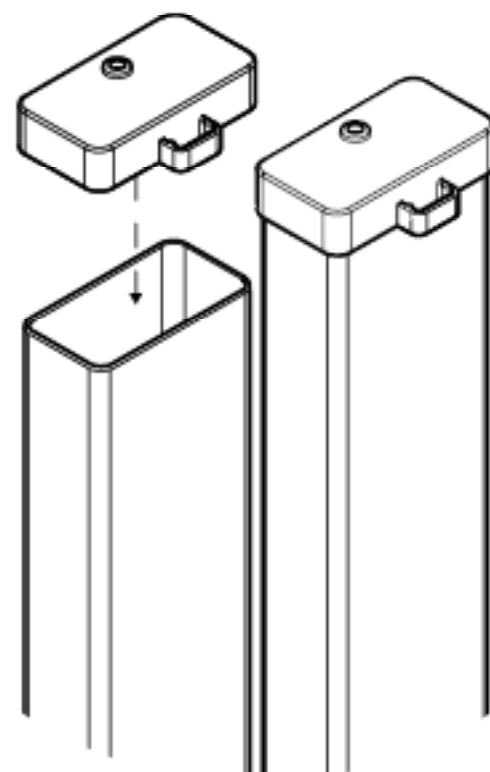

## INSTALLING

### Where to put them

Identify the height from the ground that you wish to mount the unit.

TIP: It is common for chooks to toss their feed onto the ground before eating it, to discourage this wasteful habit mount the feeder at a height that they can reach with their beaks and not their feet.

Position out of the rain to minimise the chances of spoiled feed.

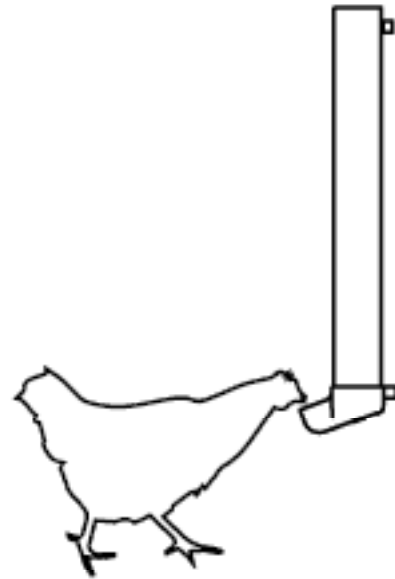

### Mounting the hooks

REQUIRES:

FAST078 - Hook (x2)

FAST002 - Bolt (x2)

FAST005 - Nut (x2)

FAST077 - Washer (x2)

6mm drill bit

The units are hung using hooks. Two are supplied and recommended for each unit.

One hook is for the top saddle, mount this one on the wall first at the desired height. The other hook is to be at the height of the bottom loop.

Measure down from saddle-to-loop on the back of feeder and drinker units and make this the distance between hooks on the wall.

The feeder & drinker units can be fitted to the mesh panels or wall of the chicken coop.

The hooks can be fastened through sheet metal by drilling a 6mm diameter hole. No hole is needed when fitting through mesh, It's important to use the washer in this case.

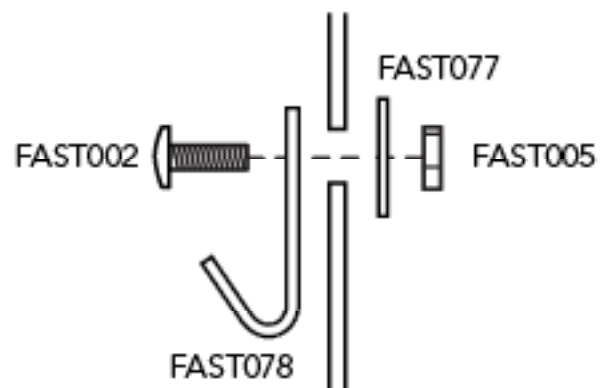
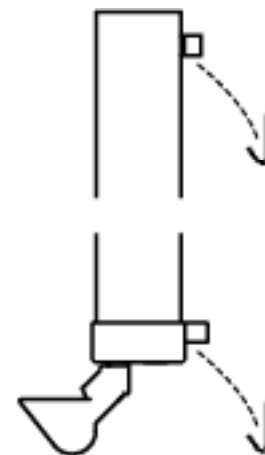

bolt / hook / wall / washer / nut

## Troubleshooting

### *Drinker is leaking*

Check the seal made between the endcap and the pipe. If this is found to be the source of the leak due to a bad silicone joint it will have to be done again.

A method to separate the endcap and pipe is squeezing in on both wide faces of the pipe, flexing them inward, breaking the seal. Next hold the cap firmly and wiggle the pipe free. Be sure to follow the joint sealer instructions when reapplying.

If the source of the leak is found to be the hole for the cup it may have been overtightened when originally assembled. Try taking it out, applying thread tape and fitting again.

### *Feeder is blocked*

Position the feeder in a spot that means it won't get wet. Use the supplied plug to resist water entry.

The wall of the pipe directly above the feed slide can be carefully cut away to offer less resistance to feed, but be careful as removing too much will make it run out and over the edge of the feeder slide.

Another cause of blockages can be spoiled feed, be sure to clean the pipes regularly as this will stop it from being blocked and also help with the health of your chooks.

### *There is no water in the orange Drinker cup.*

Chooks will naturally peck the yellow coloured valve and this releases water which is gobbled-up straight away.

If you are certain that the chooks have not figured it out you can train them by placing a piece of feed on the valve, when they peck it water will be released.



# CHICKEN COOP MODEL: AOGC15081HC

1.52mW x 0.78mD x 1.80mH

---

## Absco Sheds Storage Guidelines

- Absco Sheds are designed to be weatherproof for normal weather conditions. In the event of extreme weather conditions such as heavy rain, combined with high wind gusts, the ridge capping, sheeting joints, screw fixings etc., may exhibit minor deformations which may allow some water entry. These areas should be checked regularly to ensure that maximum strength and protection is maintained.
- Other weather conditions such as extreme heat and extreme cold, moist or dry air can influence the effects of concrete floor moisture and/or condensation on the underside of the roof sheets.
- Absco Sheds and storage units are primarily used for storage of garden equipment such as lawnmowers, wheelbarrows, garden tools etc. Storage items that might be adversely affected by any of the above conditions may require additional protection such as being sealed or covered by plastic sheets and/or stacked above the concrete floor on timber slats.
- Waterproof sealants may be used to offer further protection where required around joins and screw fixings, as can rubber door seals and other products which are available from most hardware outlets.
- Placement of waterproof sealants (silicone) between the base of the shed and concrete slab is not recommended, as this process can have a reverse effect, preventing excess water from escaping, resulting with water accumulating and being trapped inside the shed.
- Absco accepts no responsibility for water entry, floor moisture, condensation or the condition of the Contents inside your Absco steel building arising from any of the pre-mentioned weather conditions.





# CHICKEN COOP MODEL: AOGC15081HC

1.52mW x 0.78mD x 1.80mH

---

## Australia Product Warranty Against Defects

- Organic Garden Co. Sheds, including garden sheds, aviaries, storage units are made using high quality Australian made steel.
- We are pleased to advise we warrant that the steel coating will not rust, crack, flake peel or blister for 30 years from date of purchase, when installed within Australia.
- This warranty does not apply to surface deterioration of panels caused by 'Swarf' (Tiny particles of steel debris left from cutting, grinding or drilling operations) that has not been removed after building construction, or as a result of contact with damp soil, chemicals, fertilisers or other corrosive substances.
- This warranty covers any Absco product used for normal domestic use and installed in accordance with the installation instructions.
- The warranty does NOT cover Damage caused by storms, wind, rain snow or poor foundations.
- This warranty does NOT cover ABSCO products installed in severe coastal, industrial or other highly corrosive environments. The warranty does not cover fasteners (screws, nuts, bolts, rivets, hasps or sliding padbolts).
- The warranty is limited to replacement and delivery of components and does not include any labour or installation costs. The benefits given by the warranty are in addition to your other rights and remedies under a law in relation to the goods or services to which the warranty relates.
- The warranty applies to the exclusion of all other representations, guarantees or warranties express or implied, our goods come with guarantees that cannot be excluded under the Australian consumer law and is not transferable. You are entitled to a replacement or refund for a major failure and for compensation for any other foreseeable loss or damage. You are also entitled to have the goods repaired or replaced if the goods fail to be of an acceptable quality and the failure does not amount to a major failure. For further information go to <http://www.consumerlaw.gov.au>
- Please retain a proof of purchase (sales docket or invoice) or register your warranty within 30 days of purchase here: <http://abscosheds.com.au/warranty-details/>
- In the unlikely event a warranty claim is made, it must be supported by photographic evidence and details of the defect, including component part numbers, together with proof of purchase documentation (or on-line registration of purchase) and forwarded to the address below. Upon receipt of the warranty claim, the Customer Service Manager will contact you within three business days to advise you of the assessment outcome of the claim, which may include your expenses incurred in making the claim.

THE CUSTOMER SERVICE MANAGER, ABSCO INDUSTRIES, PO BOX 119 ACACIA RIDGE QLD AUSTRALIA 4110

PHONE: 1800 029 701 FAX: 07 3344 1191 EMAIL: [warranty@abscos.com.au](mailto:warranty@abscos.com.au)

Issued 01 January 2018