

**DOWNLOAD  
OUR APP FOR  
ASSEMBLY  
VIDEOS**



\*Most models available

### PLEASE LEAVE A REVIEW

Tell us about your experience!  
Visit [www.absco.sheds.com.au/review](http://www.absco.sheds.com.au/review)

## GENERAL INSTRUCTIONS

- Before commencing any assembly, read through these instructions in detail to gain a thorough understanding of assembly methods and associated details.
- Unpack the carton and carefully identify and check off all the parts against the parts described and illustrated on "COMPONENTS PACKING LIST" pages.

## SITE PREPARATION

- The site for the shed must be level. An uneven surface may result in misalignment of parts.
- The shed shall be erected on top of a reinforced concrete slab and anchored down appropriately illustrated on "FINAL CONSTRUCTION" page.

## SAFETY NOTES

- Some parts may have sharp edges. It is advisable to wear gloves when handling these items and safety glasses if drilling holes. Sensible shoes are highly recommended.
- Do not erect your shed in windy conditions.
- Ensure that the shed is securely anchored to a solid foundation immediately after construction is completed.
- It is highly recommended to erect the shed with two or more people.
- Do not sit, stand or walk on the roof of your shed.

## RECOMMENDED



Personal protective equipment for tools



Hand Protection



Enclosed Shoes



Raised work surface. EG Sawhorses and timbers



Heavy and/or bulky. Multi-person lift or mechanical aid.

## TOOLS REQUIRED

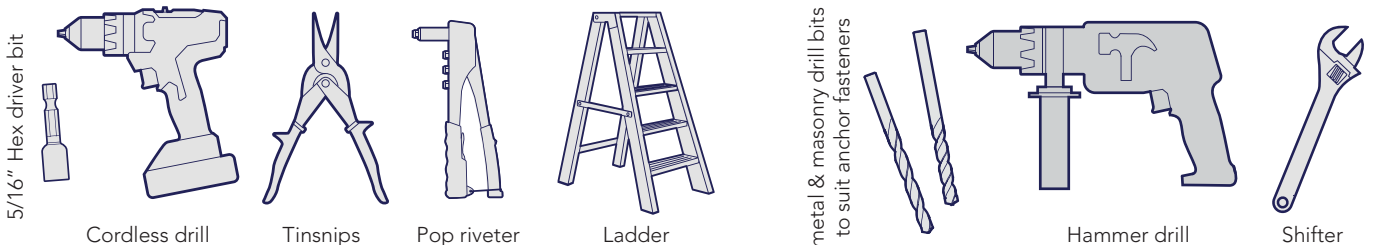

## NUMBER OF PEOPLE REQUIRED



2 people

## NUMBER OF HOURS REQUIRED



Approx. 8 hours





## ASSEMBLY DIFFICULTY

Basic



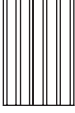
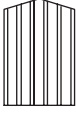
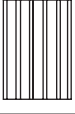
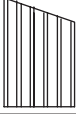







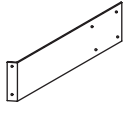

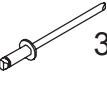
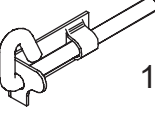
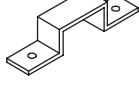

Complex

**SHEETING**

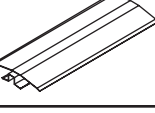
QTY	COMPONENT DESCRIPTION	PART No.	CHK	QTY	COMPONENT DESCRIPTION	PART No.	CHK
1	 STEEL SHEET 1725 x 711mm	<b>37A</b>		1	 STEEL SHEET 1980 x 773mm	<b>42D</b>	
1	 STEEL SHEET 1785 x 773mm	<b>30E</b>		1	 STEEL SHEET 1915 x 773mm	<b>260C</b>	
4	 STEEL SHEET 1170 x 773mm	<b>49A</b>		1	 STEEL SHEET 1915 x 773mm	<b>36L</b>	
5	 MESH SHEET 1195 x 705mm	<b>MESH20</b>		5	 STEEL SHEET 600 x 773mm	<b>31D</b>	

**INSTRUCTIONS AND FITTINGS PACKET**

1	 DOOR PLATE	<b>12A</b>		1	 8G x 10mm SELF TAPPING SCREW PACK QTY 220	<b>FAST001 PACK220</b>	
6	 3mm POP RIVET	<b>FAST009</b>		15	8G x 20mm SELF TAPPING SCREW	<b>FAST013</b>	
1	 PADBOLT 115mm LONG	<b>FAST006</b>		1	 PADBOLT HASP	<b>FAST007</b>	
6	 3/16 x 1/2" CSK SCREW & NUT	<b>FAST004 FAST005</b>		1	 PHILLIPS HD DRIVER BIT	<b>FAST038</b>	
1	 3mm DRILL BIT	<b>DRILL</b>		3	 CHANNEL JOINER	<b>CSJ</b>	
1	 GABLE LEFT 1105mm	<b>17L</b>		1	 GABLE RIGHT 1105mm	<b>17R</b>	
1	 RIDGE BEAM 1513mm	<b>97C</b>		1	 BRACE 350mm	<b>13B</b>	
2	 GABLE CAP	<b>14A</b>		1	 PEAK BRACE 450mm	<b>15A</b>	

Nominal sheet widths are shown +/- 2 mm is within tolerance

**COMPONENT PACKING LIST**

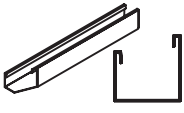
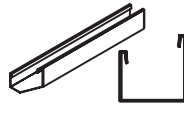
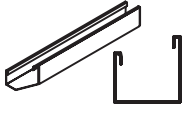
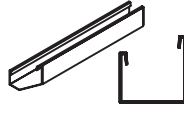
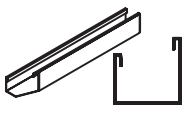
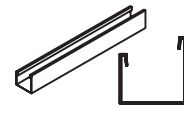
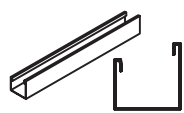
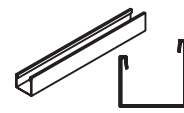
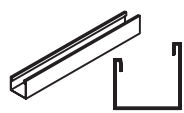
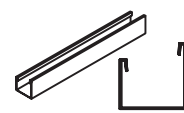
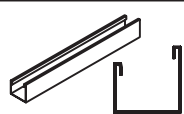
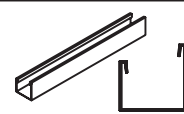
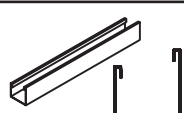
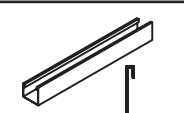
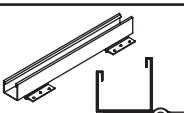
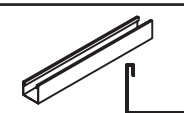
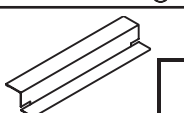
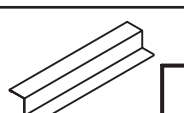
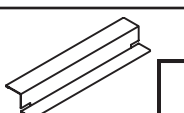
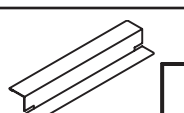
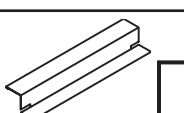
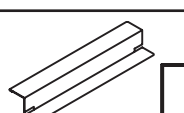
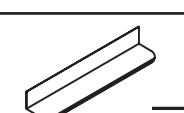
CHANNEL PACK							
QTY	COMPONENT DESCRIPTION	PART No.	CHK	QTY	COMPONENT DESCRIPTION	PART No.	CHK
2	 CHANNEL 1112mm	<b>315L</b>		2	 CHANNEL 1112mm	<b>315R</b>	
1	 CHANNEL 1126mm	<b>81DL</b>		1	 CHANNEL 1126mm	<b>81DR</b>	
3	 CHANNEL 1785mm	<b>80L</b>		1	 CHANNEL 1513mm	<b>78C</b>	
1	 CHANNEL 1143mm	<b>83L</b>		1	 CHANNEL 1143mm	<b>83R</b>	
2	 CHANNEL 1498mm	<b>150</b>		2	 CHANNEL 1498mm	<b>151</b>	
2	 CHANNEL 712mm	<b>58M</b>		10	 CHANNEL 712mm	<b>181</b>	
1	 CHANNEL 1725mm	<b>58B</b>		1	 CHANNEL 720mm	<b>54G</b>	
1	 CHANNEL 1725mm	<b>58A</b>		2	 CHANNEL 1513mm	<b>81E</b>	
9	 JAMB 1785mm	<b>70D</b>		2	 JAMB 1080mm	<b>91E</b>	
1	 JAMB 1785mm	<b>89A</b>		1	 JAMB 1785mm	<b>89B</b>	
1	 JAMB 720mm	<b>91D</b>		1	 JAMB 1204mm	<b>70E</b>	
4	 LIP TRIM 1546mm	<b>86A</b>					

## SNAPTITE ASSEMBLY GUIDE

The Snaptite Assembly System locks end channels to all roof and wall sheets without the need for tools and fasteners.

To assemble each panel, the perimeter channels are secured to the top and bottom of each panel. Gently tap the channel over the SNAPTITE lugs on the sheet, working along the sheet.

Each perimeter channel must finish flush with the edges of the sheets. Simply tap the channel along the sheets until each end is neatly flush. If you need to remove channels from the panels, slide it off from the side.

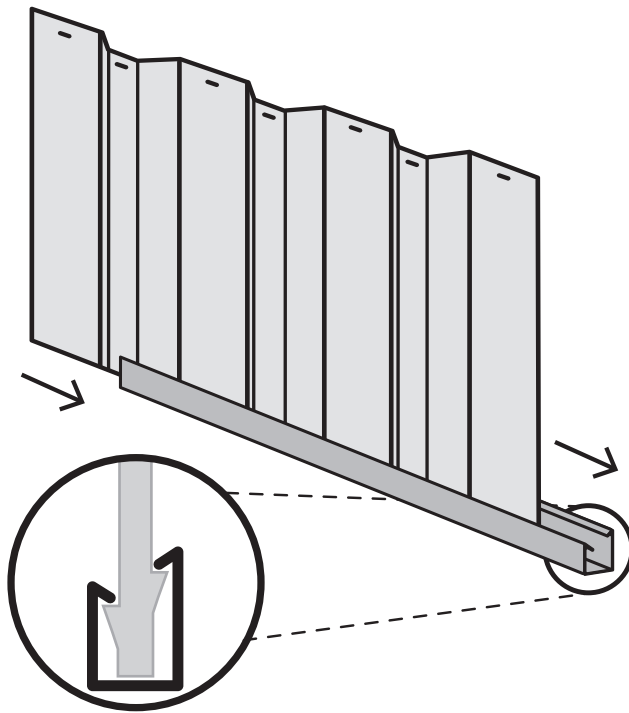

**SNAPTITE**  
World's Easiest Assembly System  
*UNIQUE PATENTED SYSTEM*

Channel locks the shed panel into position without the need for screws!

### FASTENING SYMBOLS

**SNAPTITE**

Secure channel to sheeting by SNAPTITE fastening method.



Join components together with one screw at this location only, as some channels have extra holes that are not required for this model of shed.

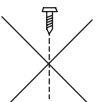

Do not join components together at this location yet, as the screws may obstruct further assembly of the other components.



Join components together by pre-drilling the holes first. Use one component as template to mark where the holes are and drill with a 3mm drill bit.



3mm pop rivet



4mm nut and bolt set.

## Guide on Joining Spliced Channels

The text marked on all parts must be shown on the same side as each other



**Step 1.**  
Position the channels and the CSJ joiner so the centre of the CSJ is in line with the end of each channel to be joined together.

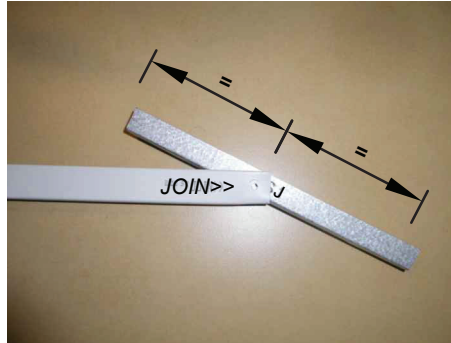

**Step 2.**  
Join the first channel to the CSJ by inserting the centre of the CSJ, on an angle, to the end of the channel where the JOIN>> text is marked.

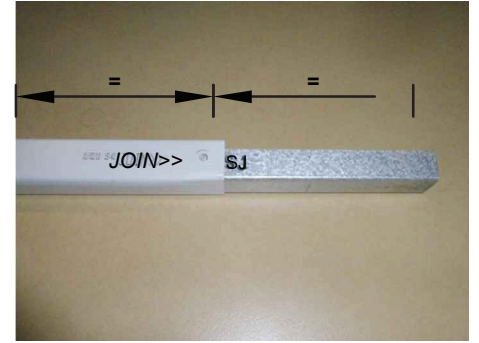

Push down one side of the CSJ until you hear a 'click'.

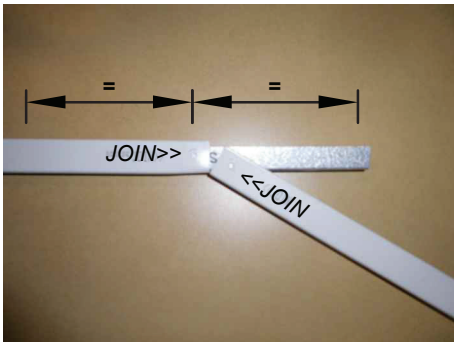

**Step 3.**  
Join the second channel to the CSJ by positioning the <<JOIN of the channel at the centre of the CSJ, on an angle. Push the CSJ into the channel until you hear a 'click'.

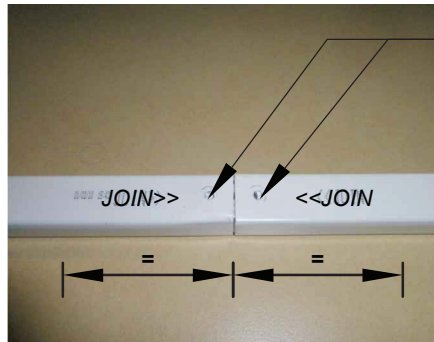

**Finished Channel.**  
The joined channels should now look like the picture with the CSJ positioned equally inside of the joined channels.

Drill out holes with 3mm drill bit in CSJ to match the holes in channel and secure with the screws supplied. These may have to be temporarily removed during assembly.

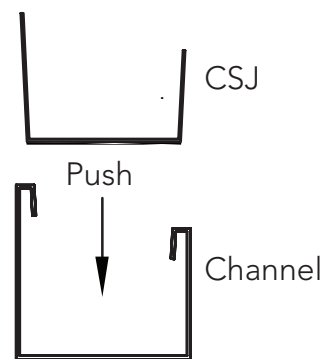

...

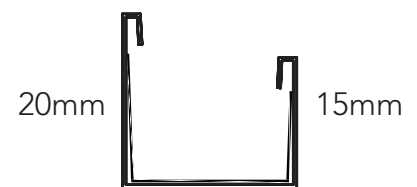

Finished Spliced Channel

## PRE-ASSEMBLY OF SPLICED CHANNELS

Join together 6 x channel sections using 3 x channel joiners (Part CSJ)

NOTE: Some channels may have holes in them - You will need to redrill holes where CSJ joining channel covers them.

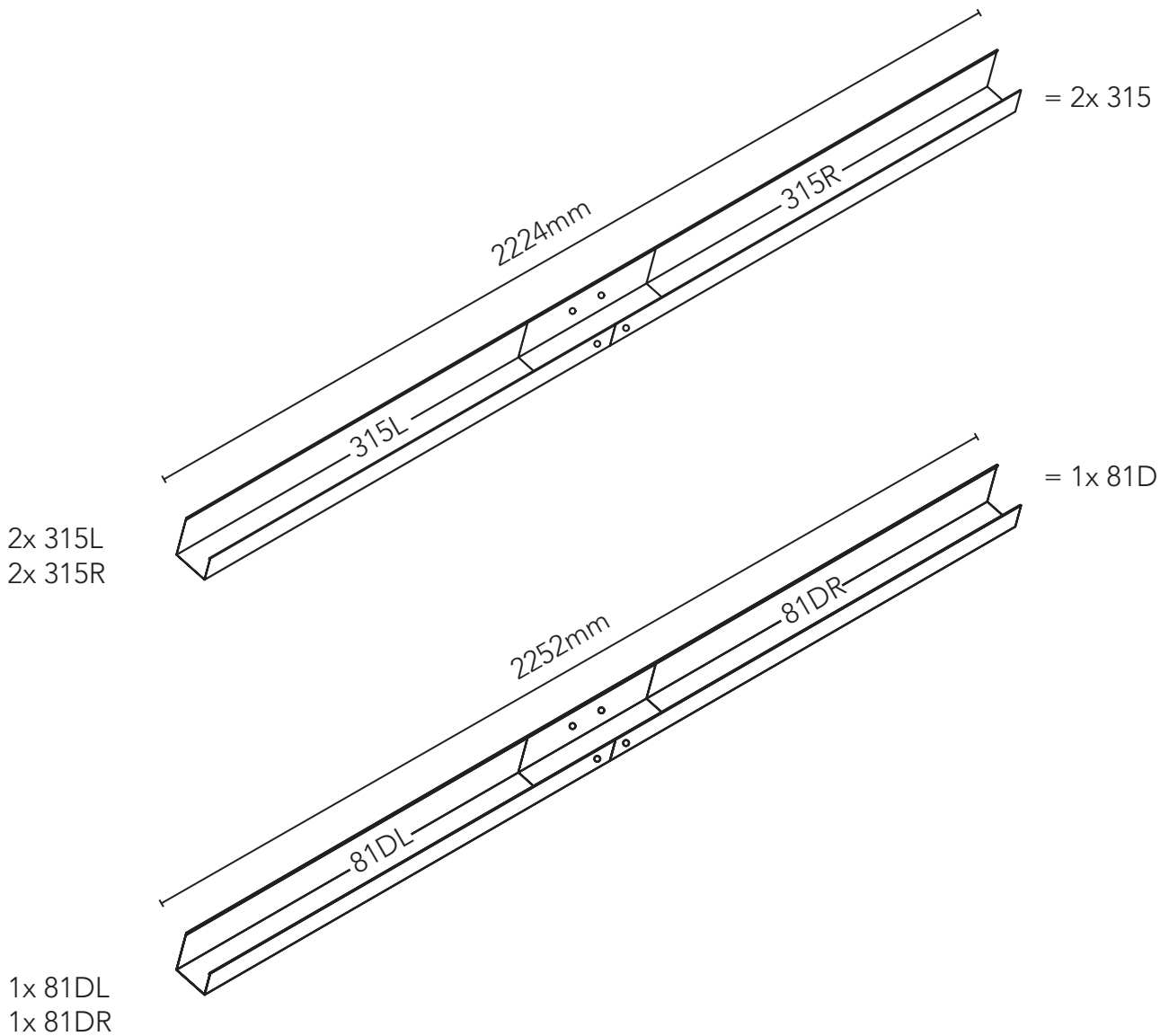



## GENERAL OVERVIEW

Mesh panels not shown for illustrative purposes.

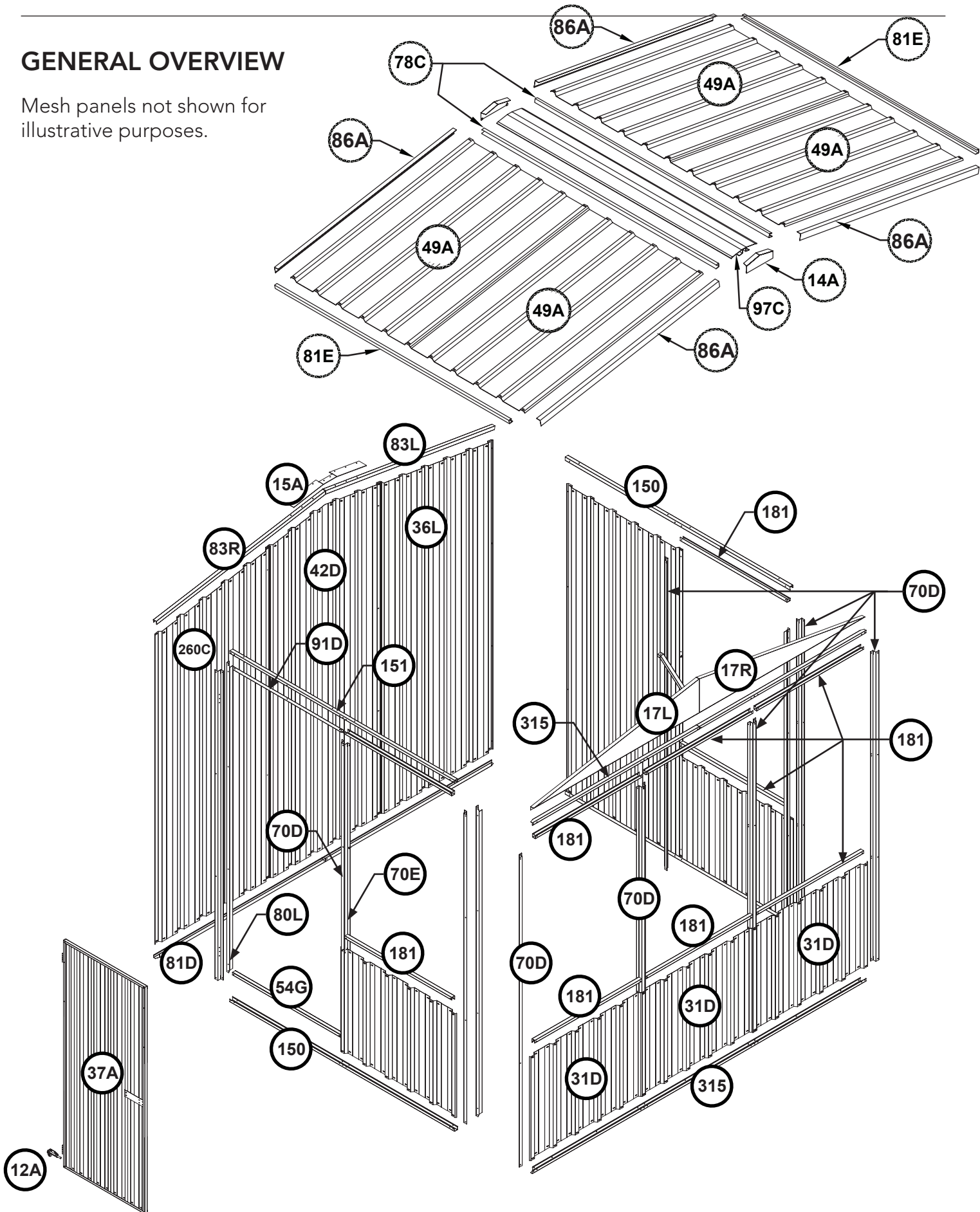



**ROOF PANEL**

2x required

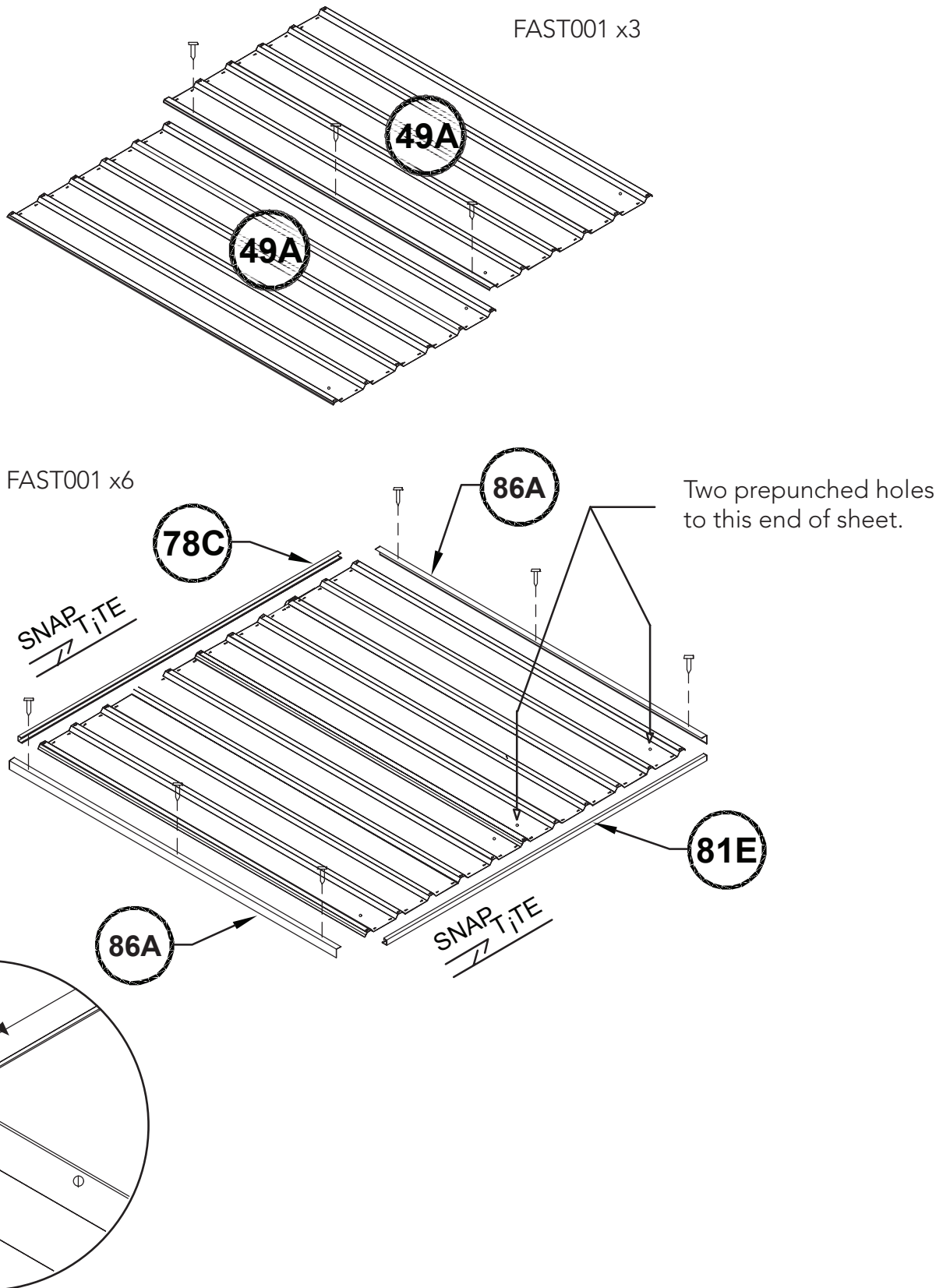

**RIGHT SIDE PANEL**

1x required

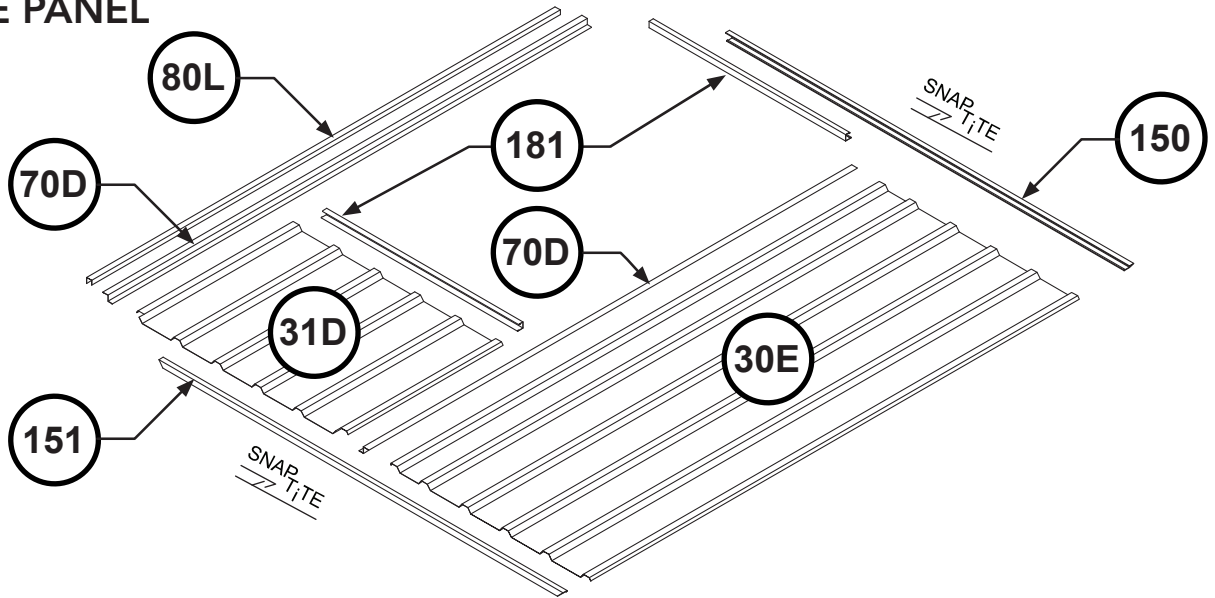

Part overview

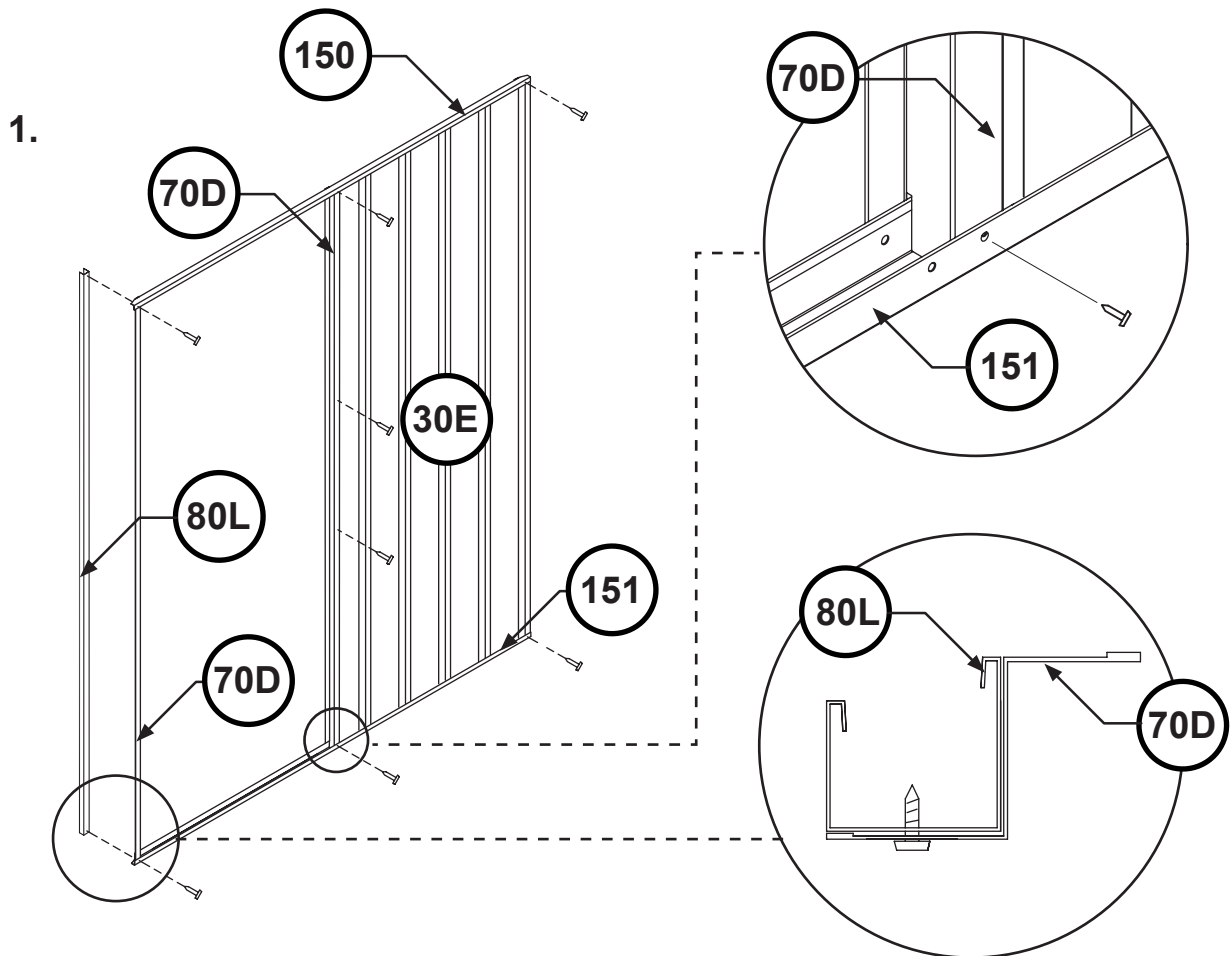

**RIGHT SIDE PANEL**

**2.**

Prepare a short sheet

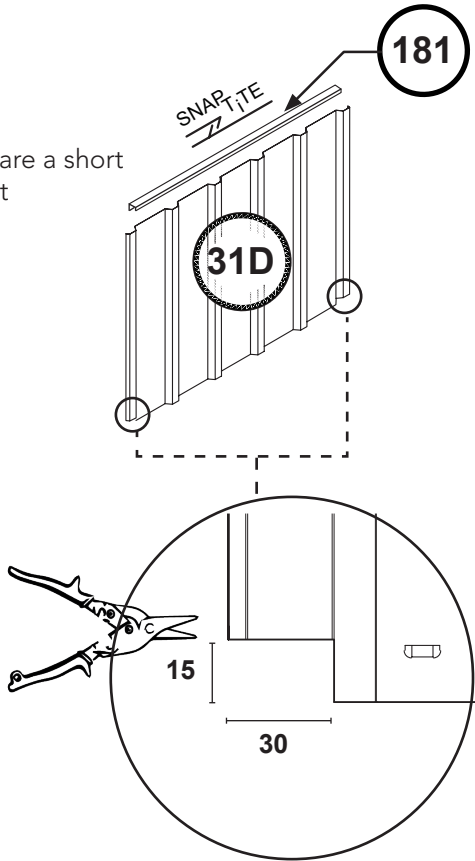

Notch out both bottom corners as shown using tinsnips.

**3.**

FAST001 x2

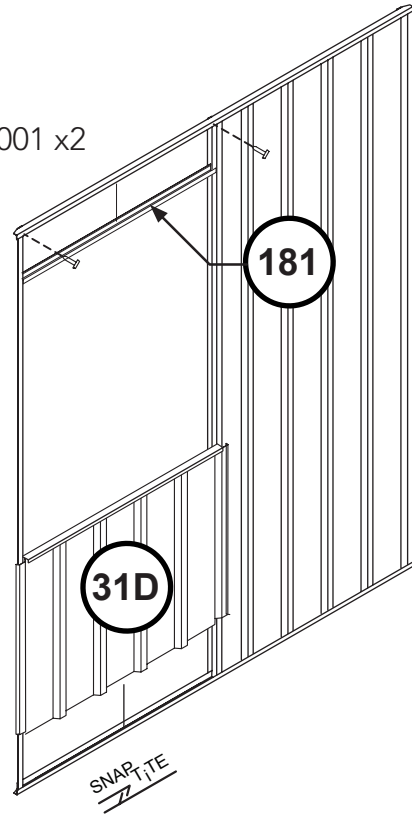

**4.**

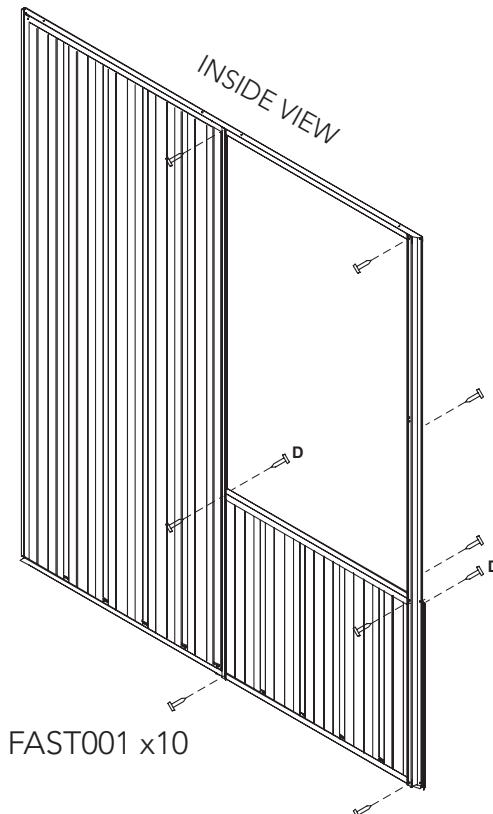

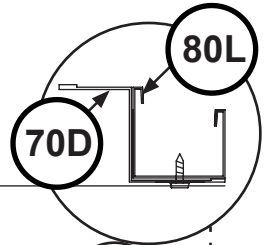

## LEFT SIDE PANEL

1x required

1.

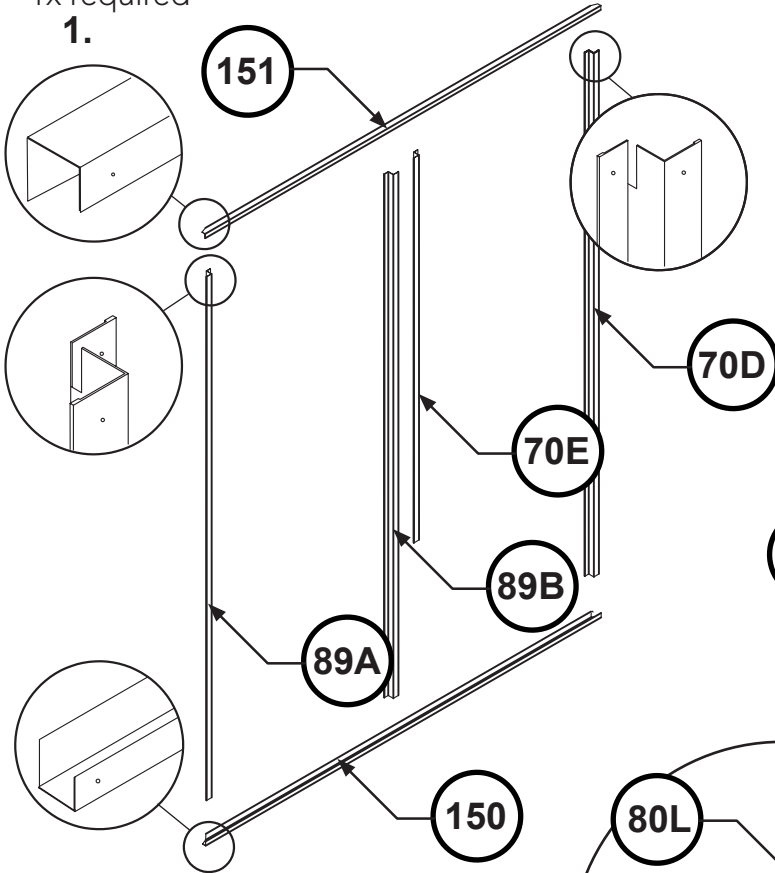

2.

FAST001 x7

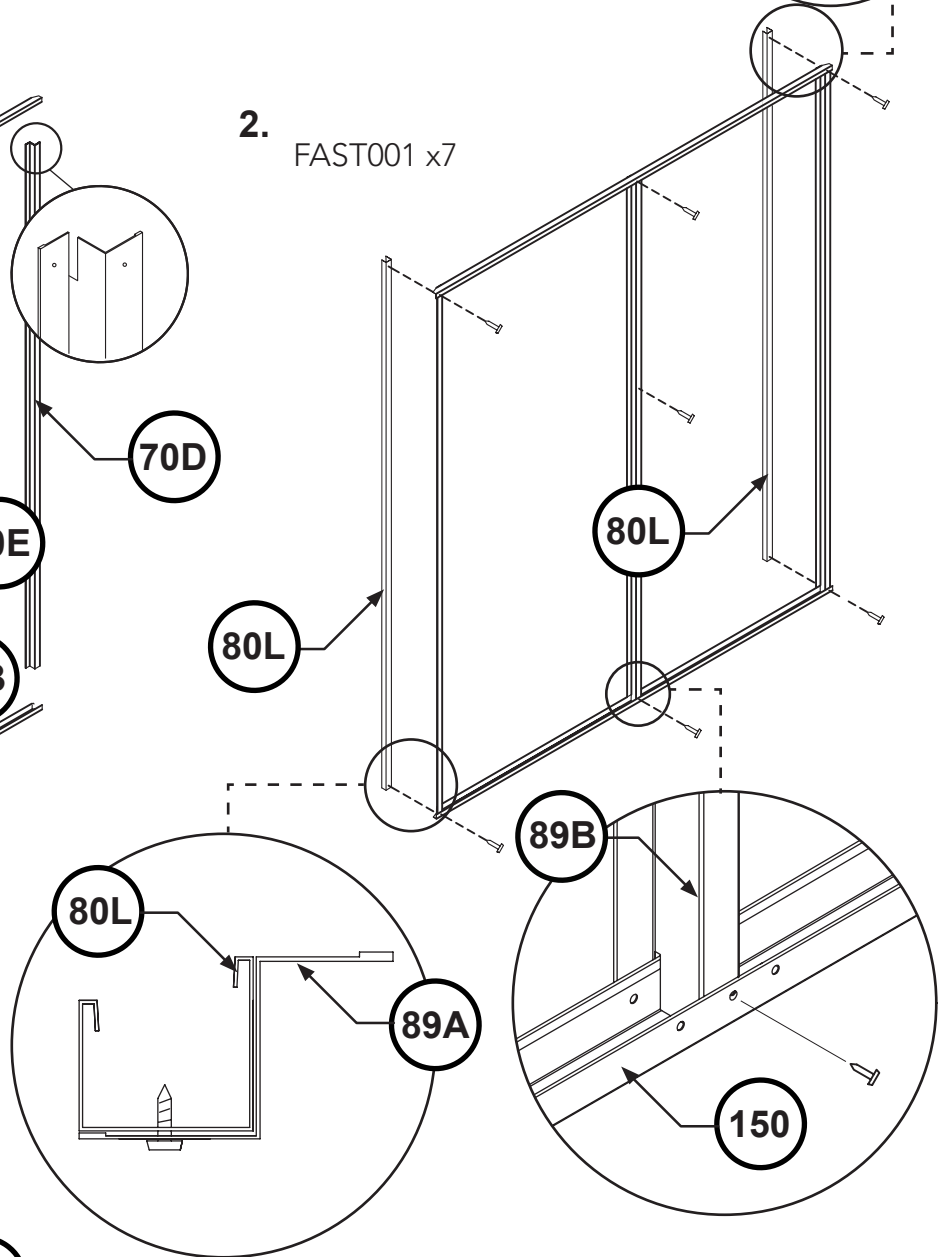

3.

Prepare one short sheet

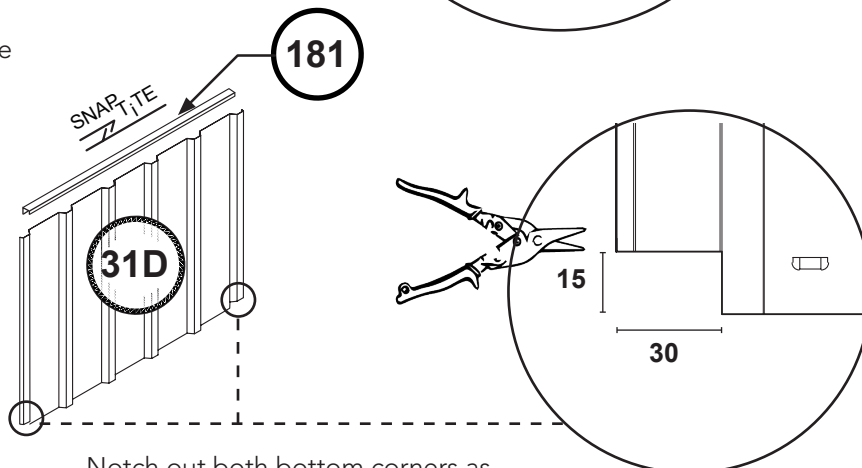

Notch out both bottom corners as shown using tinsnips.

**LEFT SIDE PANEL**

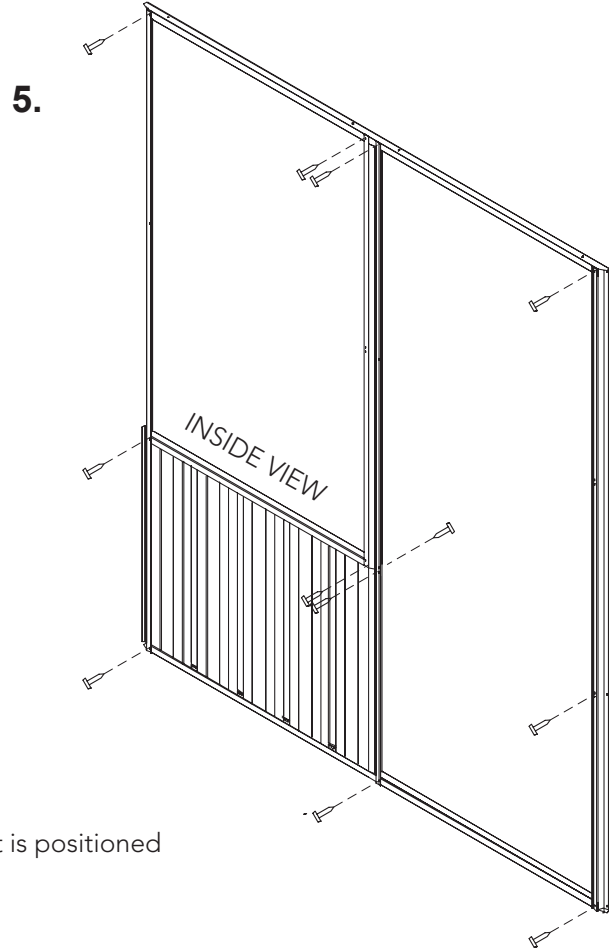
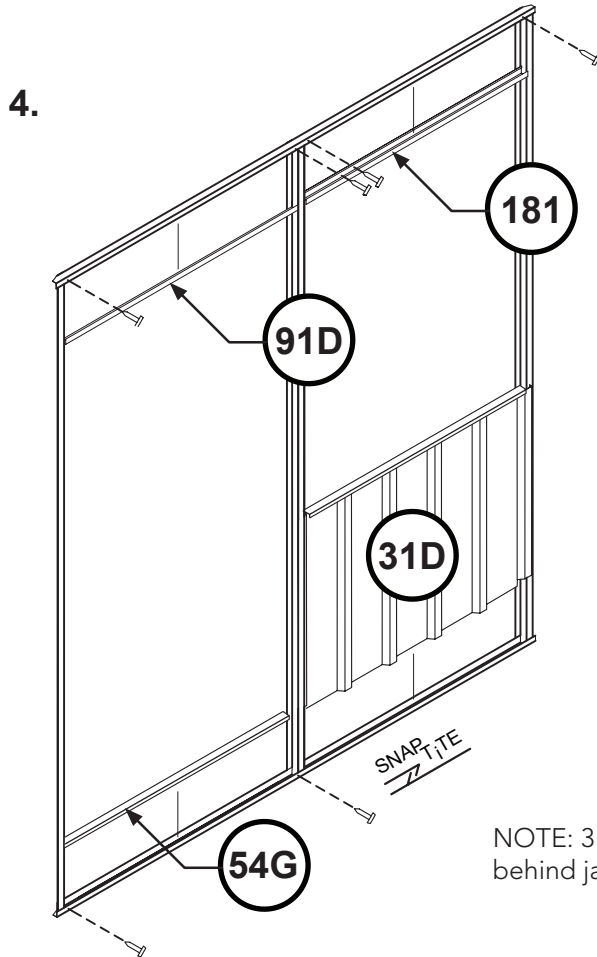

NOTE: 31D sheet is positioned behind jamb 89B

## DOOR PANEL ASSEMBLY

1x required

FAST001 x12

Narrow pan of sheet  
to this side

SNAP  
TITE

58M

Position 12A  
midway along the  
door.

58A

12A

37A

58B

58M

SNAP  
TITE

Side channels of door  
are to be orientated  
opposite to top and  
bottom channels.

20mm flange

15mm flange

FAST001 x4

FAST006

Side channels are  
positioned behind top  
and bottom channel.

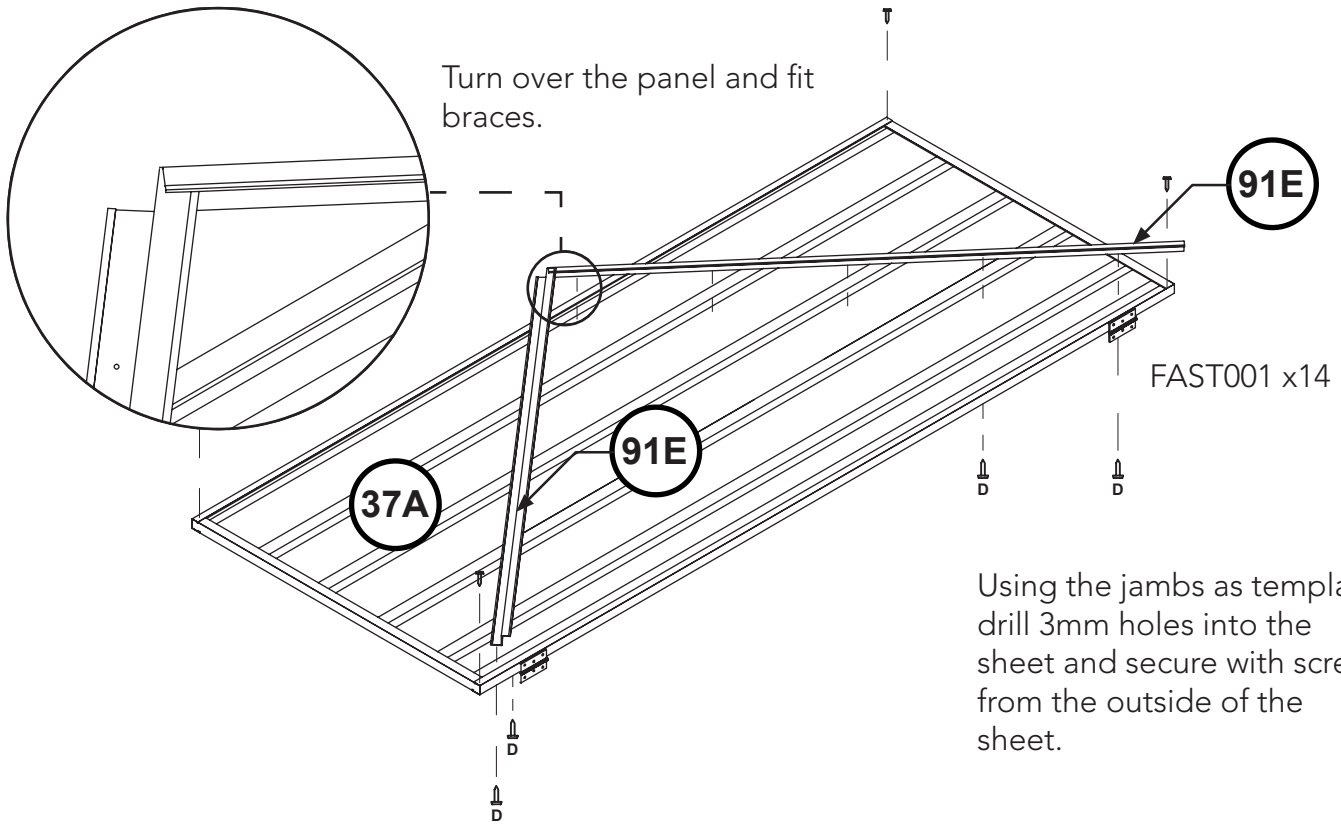

Using the jambs as templates drill 3mm holes into the sheet and secure with screws from the outside of the sheet.

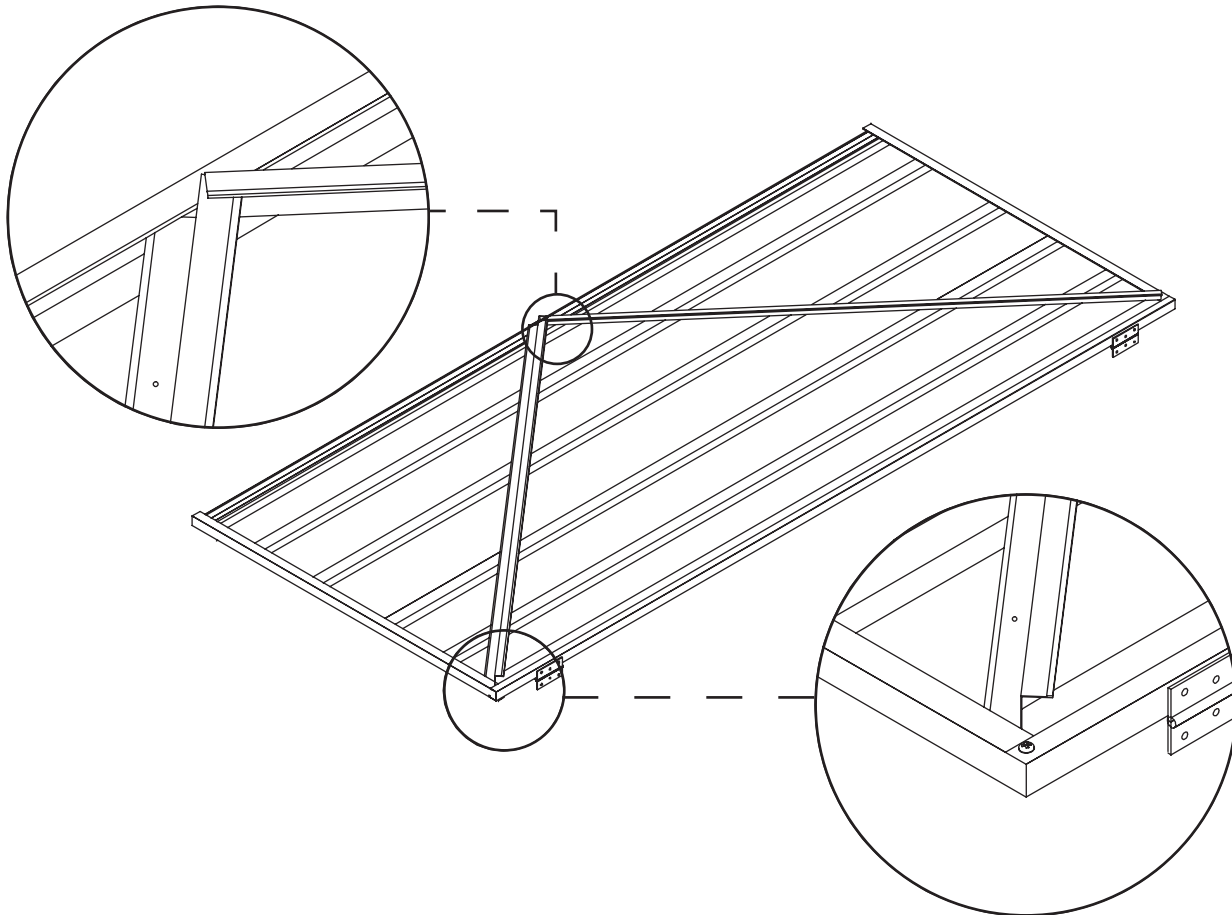



**DOOR PANEL ASSEMBLY**

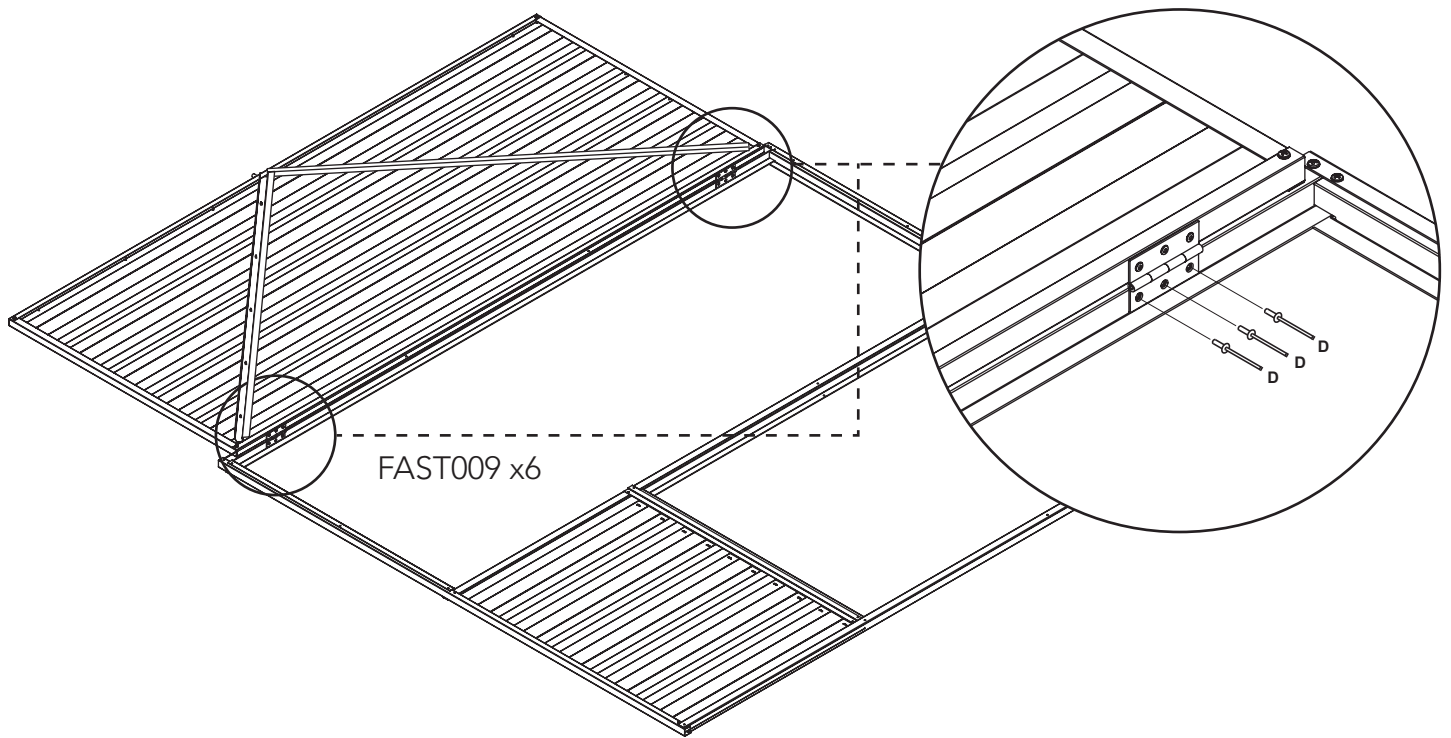

Lay the LEFT SIDE PANEL face up and lay the DOOR PANEL down in the open position on top as shown.

Using three rivets per hinge, FAST009, secure the door to the frame.

NOTE: Run the 3mm drill bit through the punched holes in the jamb before riveting the hinge on.

**REAR PANEL ASSEMBLY**

1x required

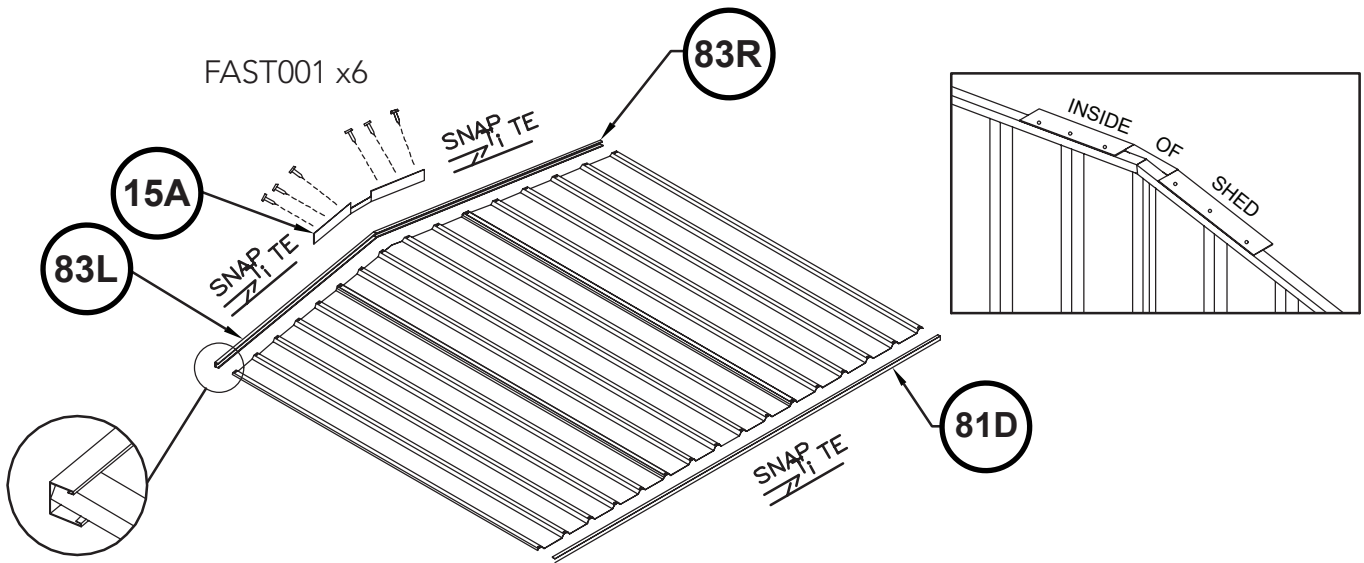
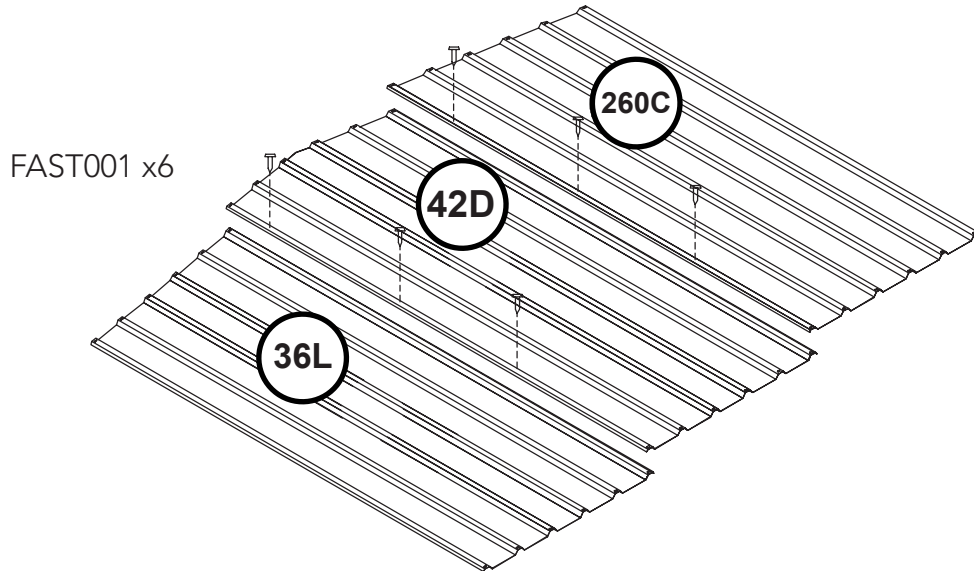

## FRONT PANEL

1x required

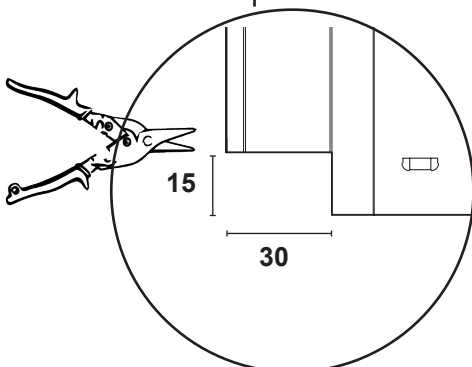
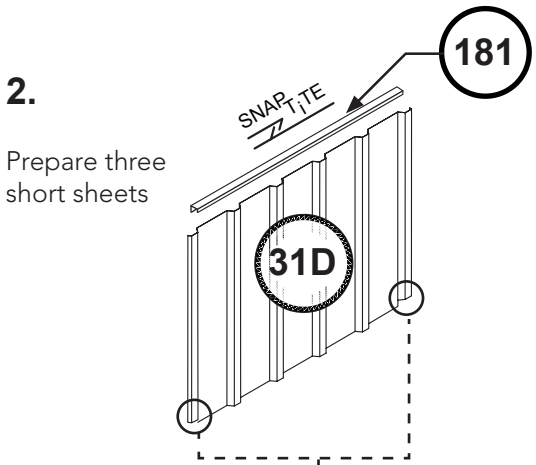
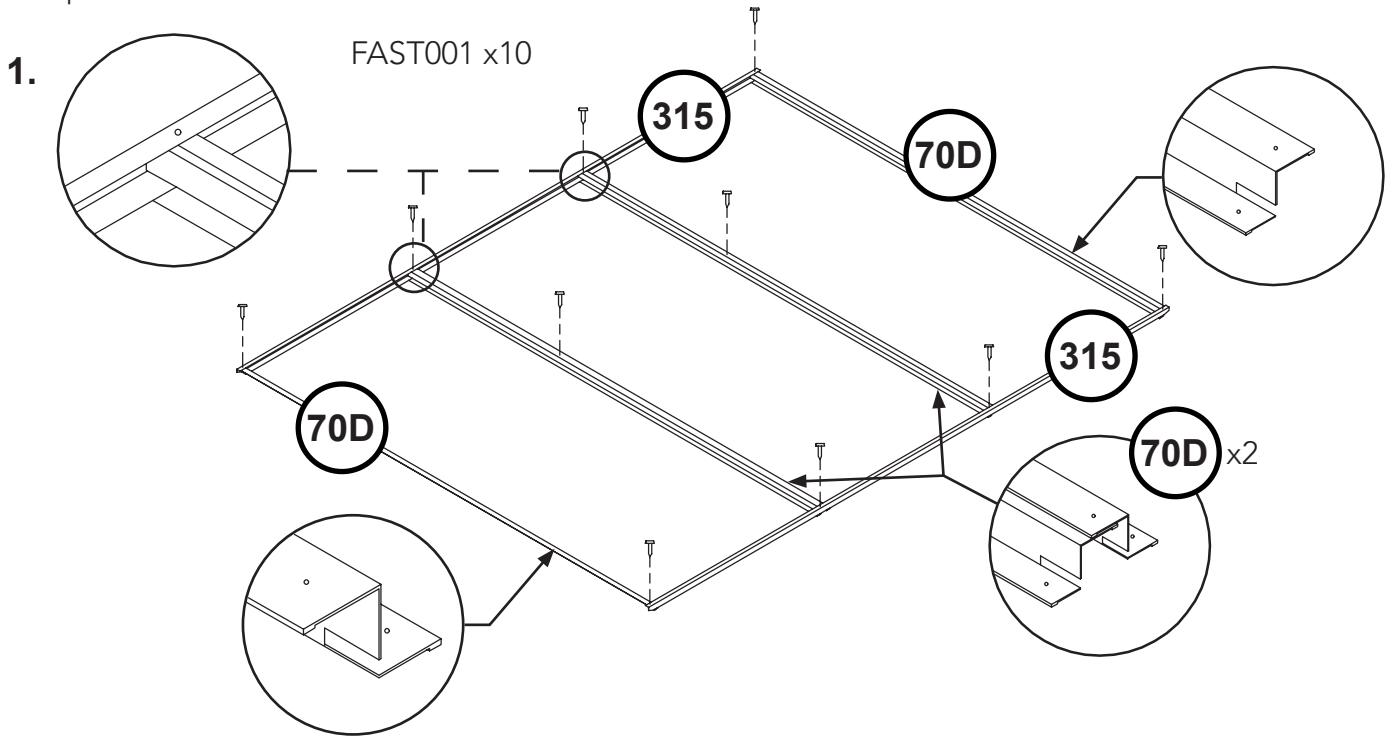

Notch out both bottom corners as shown using tin snips.

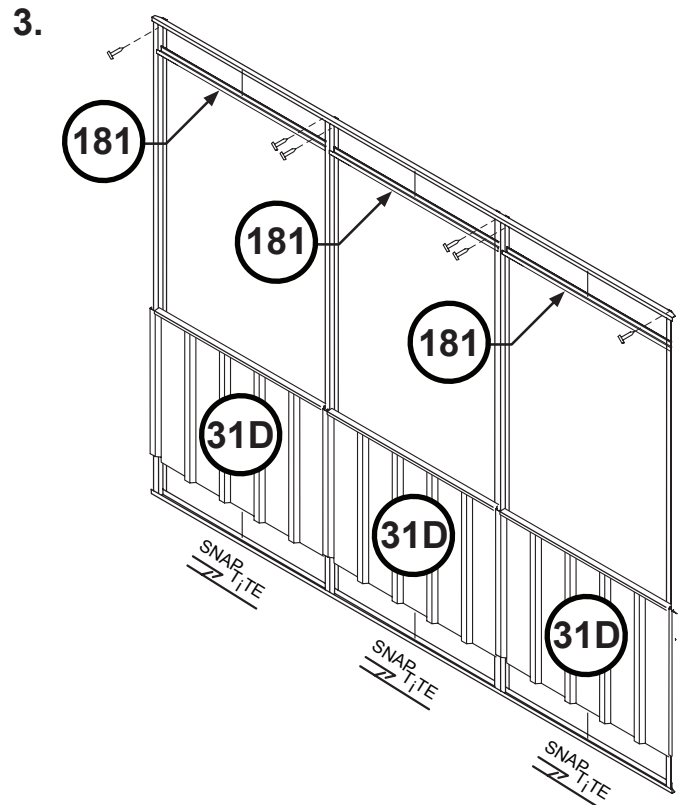

**FRONT PANEL**

4.

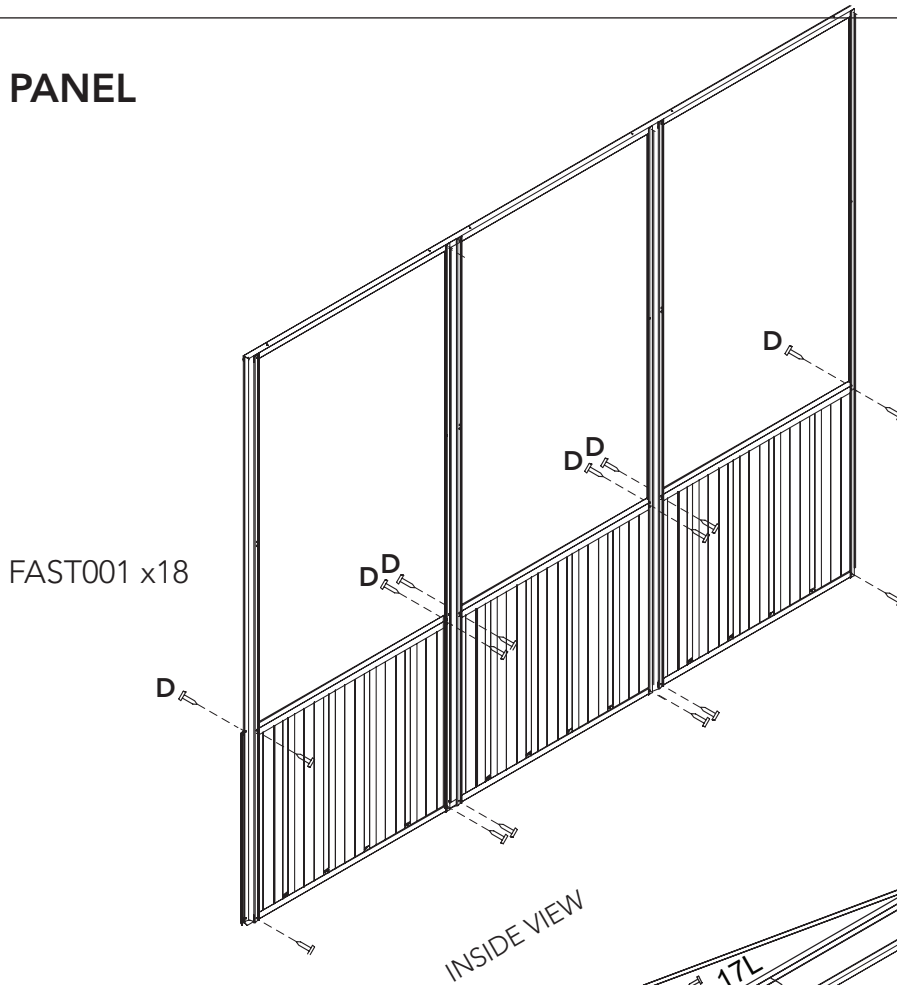

Fix the jambs from the inside of the front panel as shown.

Fixings through the 31D sheet will need to be pre-drilled.

5.

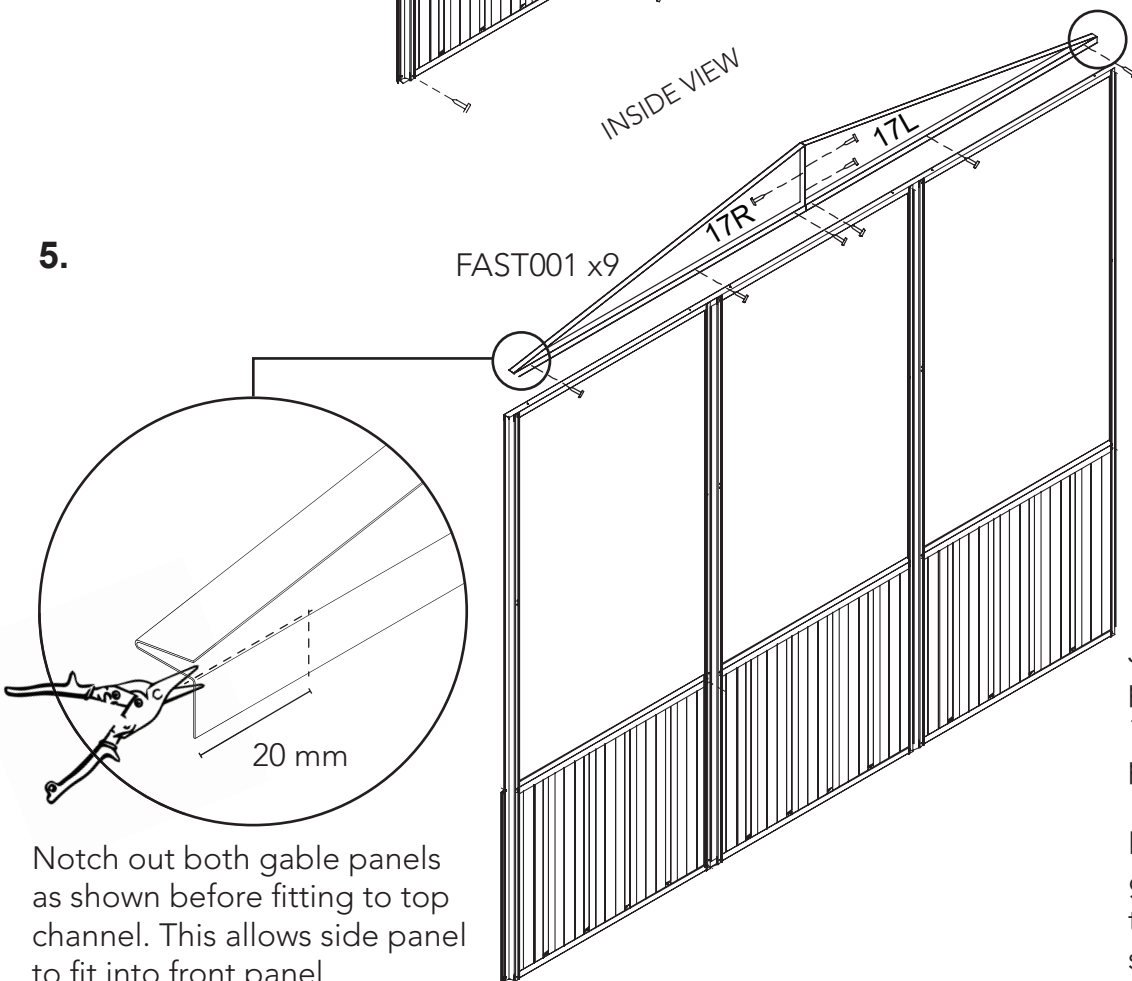

Notch out both gable panels as shown before fitting to top channel. This allows side panel to fit into front panel.

Join the gable panels 17L and 17R and move into position as shown.

Drill and screw the gable panels into the top channel as shown.

**PANEL CONSTRUCTION**

NOTE: Take care to ensure that all wall panels are not upside down. The top channels of each panel are pre-punched for attaching roof sheeting. Typically base channels are not pre-punched.

Mesh panels are not shown for illustrative purposes.

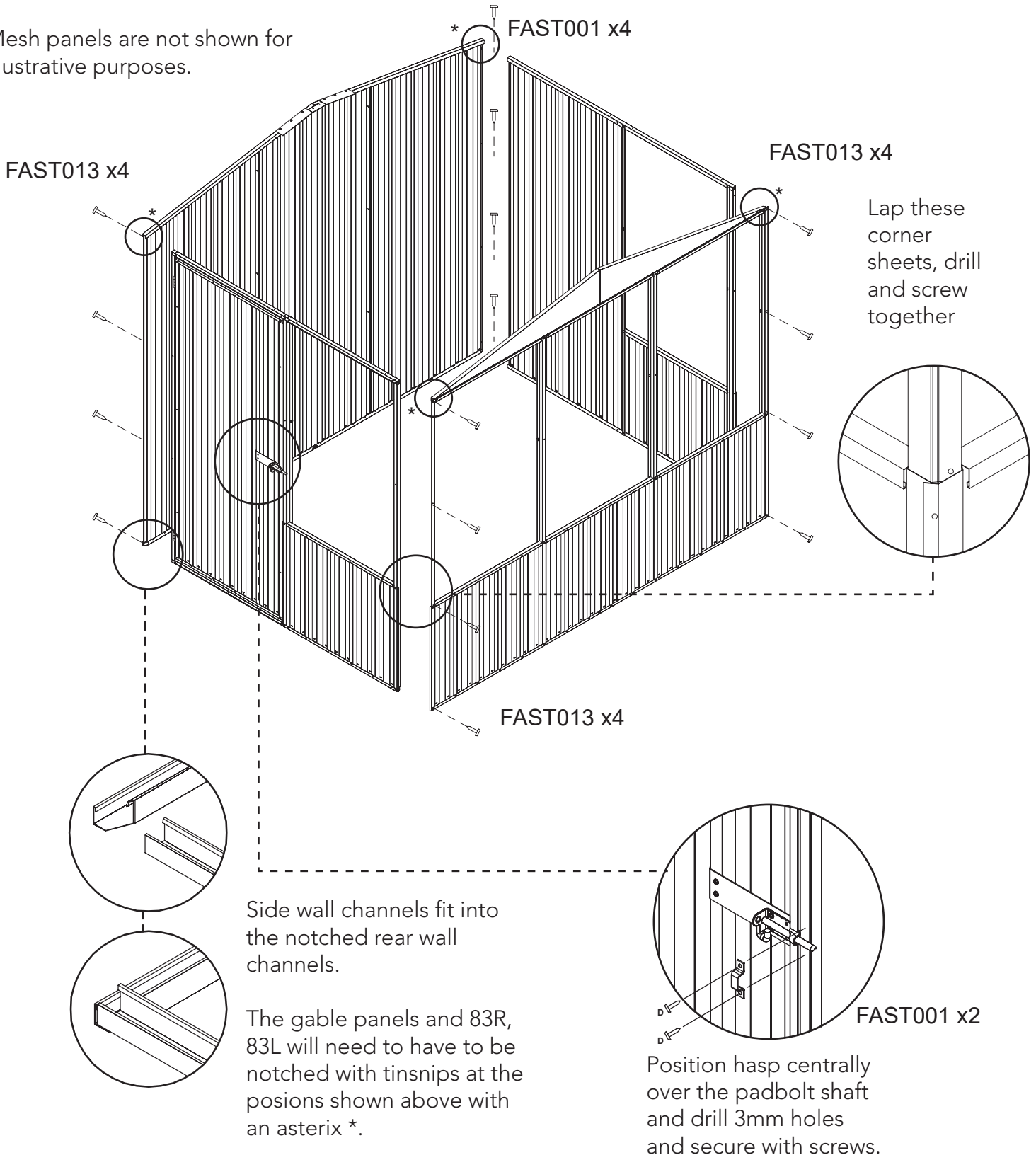

Side wall channels fit into the notched rear wall channels.

The gable panels and 83R, 83L will need to have to be notched with tinsnips at the positions shown above with an asterisk \*.

Position hasp centrally over the padbolt shaft and drill 3mm holes and secure with screws.

## ROOF CONSTRUCTION

1. Attaching the roof panel to the ridge beam.

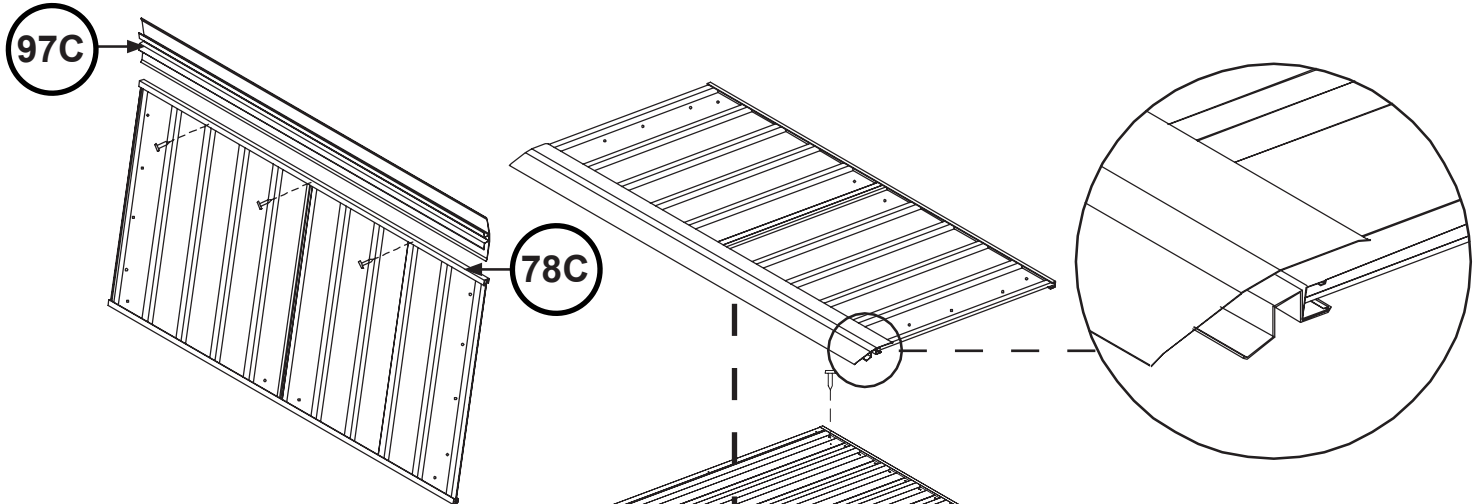

2.

Secure the ridge beams to the front and back walls with two screws at each end.

Secure the roof panel with one screw in each corner.

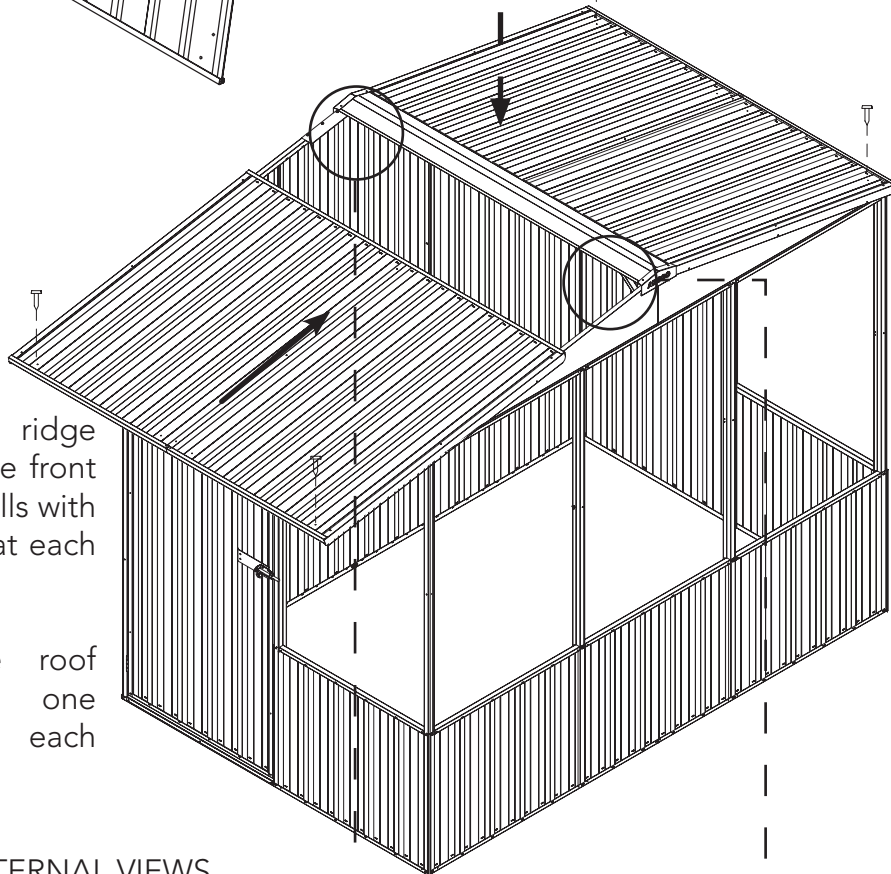

3.

Fit the second roof panel.

4.

Fit the brace to front wall as shown. You will have to replace existing screws at fixing locations

### INTERNAL VIEWS

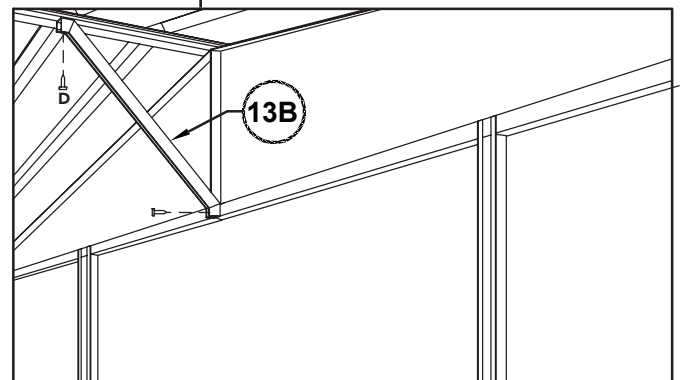
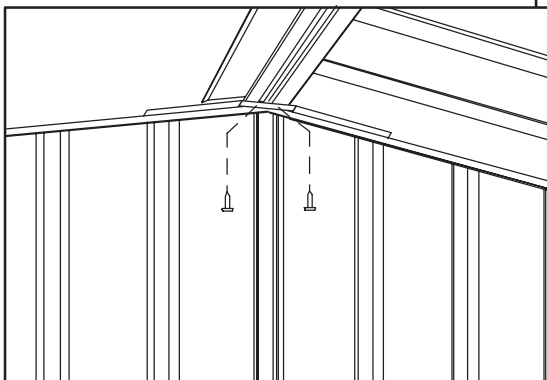



## FINAL CONSTRUCTION

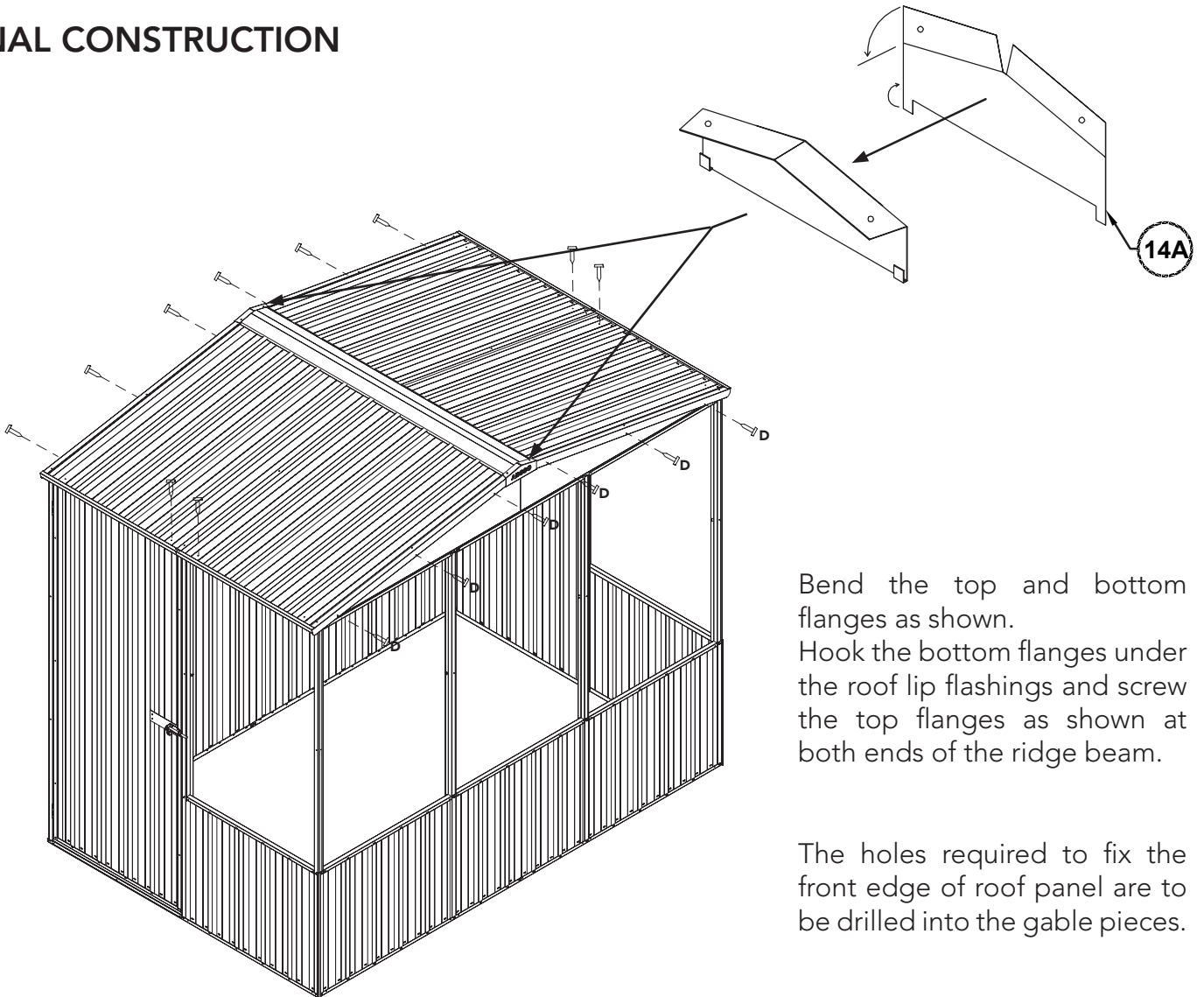

Bend the top and bottom flanges as shown. Hook the bottom flanges under the roof lip flashings and screw the top flanges as shown at both ends of the ridge beam.

The holes required to fix the front edge of roof panel are to be drilled into the gable pieces.

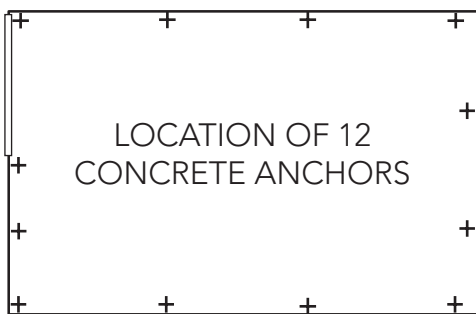

Each anchor consists of one nut, bolt, M10 dynabolt and steel angle.  
Drill a 10mm hole into the wall sheet.  
Drill a 10mm hole into the concrete.

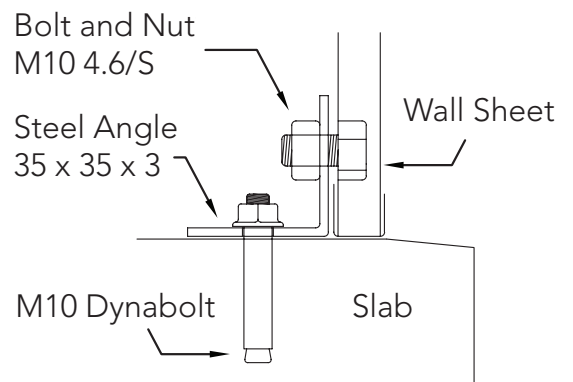



## FITTING MESH PANELS

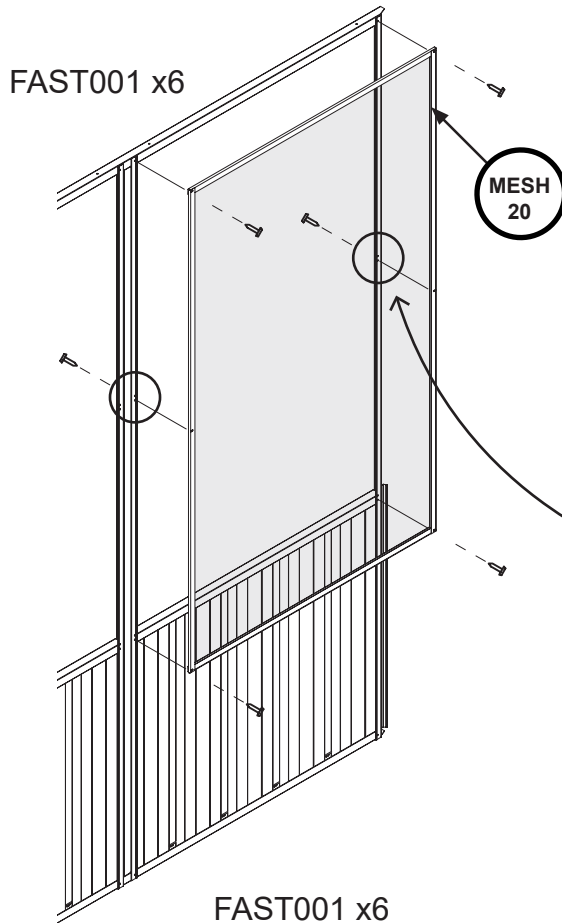

The mesh panels are fixed to the **inside** of the wall panels.

There's six holes in the border of the mesh panel, these are fixed with FAST001 screws.

1. Start by aligning the middle pair of mesh holes with these lower 70D holes and fasten with screws from outside.

2. The four corner holes are to be drilled out into the top and bottom channels using the supplied 3mm drill bit and fastened from inside the panel using four FAST001 screws.

3. Repeat these steps for every mesh position.

**NOTE:** If the mesh panel is not sitting flush enough for your liking you may drill more 3mm holes and fasten with additional FAST001.

**WARNING:** It is recommended that new galvanised mesh should be weathered for two (2) months or scrubbed with a mild acidic solution, such as vinegar, then rinsed with water before being used in bird housing applications.

## Absco Sheds Storage Guidelines

- Absco Sheds are designed to be weatherproof for normal weather conditions. In the event of extreme weather conditions such as heavy rain, combined with high wind gusts, the ridge capping, sheeting joints, screw fixings etc., may exhibit minor deformations which may allow some water entry. These areas should be checked regularly to ensure that maximum strength and protection is maintained.
- Other weather conditions such as extreme heat and extreme cold, moist or dry air can influence the effects of concrete floor moisture and/or condensation on the underside of the roof sheets.
- Absco Sheds and storage units are primarily used for storage of garden equipment such as lawnmowers, wheelbarrows, garden tools etc. Storage items that might be adversely affected by any of the above conditions may require additional protection such as being sealed or covered by plastic sheets and/or stacked above the concrete floor on timber slats.
- Waterproof sealants may be used to offer further protection where required around joins and screw fixings, as can rubber door seals and other products which are available from most hardware outlets.
- Placement of waterproof sealants (silicone) between the base of the shed and concrete slab is not recommended, as this process can have a reverse effect, preventing excess water from escaping, resulting with water accumulating and being trapped inside the shed.
- Absco accepts no responsibility for water entry, floor moisture, condensation or the condition of the Contents inside your Absco steel building arising from any of the pre-mentioned weather conditions.

# Lifetime Warranty Statement



## 1. DEFINITIONS

In this document, capitalised terms have the following meaning:

- (a) "ABSCO" means John Scholtes Investments (No. 1) Pty Ltd trading as Absco Industries.
- (b) "Authorised Purpose" means for storage (other than storage of corrosive materials), and other activities typically expected of a non-habitable structure.
- (c) "Defect" means a defect in the design, workmanship, materials, or any other defect caused by the manufacturing process of the Product (including damaged or missing parts).
- (d) "Excluded Environment" means land located within 1km of:
  - (i) salt marine locations or other areas of marine influence;
  - (ii) severe industrial or other abnormally or highly corrosive environments;
  - (iii) areas not washed by rain;
  - (iv) a recognised flood, bushfire or earthquake zone; or
  - (v) areas with uncontrolled fill, unless an engineered foundation is constructed.
- (e) "Lifetime Warranty Period" means the period of 35 years, commencing on the day after the date of purchase of the Product.
- (f) "Lifetime Warranty Statement" means this 'Lifetime Warranty Statement' document.
- (g) "Parties" means ABSCO and You.
- (h) "Product" means any of following unless stated otherwise in the product description and/or the Product Guide for the Product:
  - (i) products which utilise ABSCO 'SNAP-TITE' technology, including but not limited to garden sheds, chicken coops, bike sheds and bin covers; and
  - (ii) all non-insulated large structures such as carports, awnings, shades and garages,but does not include any product stated to be in the "ABSCO Economy" range.
- (i) "Product Guide" means the guide for installation and maintenance of the Product produced by ABSCO.
- (j) "You" / "Your" means the customer who purchased or installed the Product, or the person who owns the land upon which the Product is installed but does not include a subsequent purchaser of the Product where the Product is moved to a different location to that originally installed.

## 2. ABSCO'S STRUCTURAL WARRANTY

- 2.1. ABSCO provides this warranty to You in relation to the Product. The warranty applies to all colours and finish variants of the Product manufactured by ABSCO and sold by authorised sellers of the Product in Australia or New Zealand.
- 2.2. Subject to the terms of this Lifetime Warranty Statement:
  - (a) ABSCO warrants that the Product will be free from Defects for the duration of the Lifetime Warranty Period; and
  - (b) where the Product contains a Defect, ABSCO will either repair or replace the Product, or provide You with monetary compensation for the Defect in accordance with clause 3.

## 3. WARRANTY CLAIM PROCEDURE

- 3.1. If, during the Lifetime Warranty Period, You believe the Product has a Defect, You must comply with the procedure set out in this clause 3.
- 3.2. Within 30 days of becoming aware of the Defect in the Product, You must notify ABSCO in writing of the alleged Defect ("Defect Notice") by email to admin@absco.com.au.
- 3.3. The Defect Notice must include:
  - (a) Your name, address and contact details;
  - (b) proof of purchase of the Product, including the colour and finish of the Product;
  - (c) the date and location of the installation of the Product and details of the contractor or installer of the Product;
  - (d) details of the alleged Defect in the Product, including but not limited to:
    - (i) a clear description of the alleged Defect;
    - (ii) the date the alleged Defect was first identified; and
    - (iii) any photographs and/or video footage of the alleged Defect.
- 3.4. As soon as reasonably practicable after receipt of the Defect Notice, ABSCO will contact You to investigate the alleged Defect. You must make the Product available to ABSCO and/or its authorised representatives for inspection and testing if so required.
- 3.5. A travel fee may apply if ABSCO and/or its authorised representatives are required to inspect the Product outside a capital metropolitan city area.
- 3.6. If ABSCO's investigations reveal a genuine Defect in the Product, ABSCO may elect to either:
  - (a) repair the Product;
  - (b) replace all or part of the Product; or
  - (c) refund all or part of the purchase price paid by You as compensation for the Defect in the Product.
- 3.7. ABSCO's election in clause 3.6 is at ABSCO's sole discretion.
- 3.8. If ABSCO elects to repair the Product, ABSCO will arrange for a qualified tradesperson to attend to the rectification of the Defect as soon as reasonably practicable. The cost of the repair will be borne by ABSCO.
- 3.9. If ABSCO elects to replace the Product:
  - (a) ABSCO will arrange for the replacement Product to be available for collection by You from the nearest ABSCO authorised reseller as soon as reasonably practicable;
  - (b) You may be required to return the alleged Defective parts or components to ABSCO; and
  - (c) You will be liable for the cost of disassembly and removal of the Product and assembly of the replacement Product.
- 3.10. If ABSCO elects to repair or replace the Product and the necessary parts or components are no longer manufactured or supplied by ABSCO, ABSCO may repair or replace the parts or components with parts or components of a similar quality, grade, composition and colour. You cannot object to such an alternative.
- 3.11. If ABSCO's investigations do not reveal a genuine Defect in the Product (including a defect which is not covered by this warranty), You agree to pay ABSCO's reasonable investigation costs.

#### 4. WARRANTY LIMITATIONS / EXCLUSIONS

4.1. To the extent permitted by law, this warranty will not apply where:

- (a) the Product has been installed or used for a purpose that is not an Authorised Purpose;
- (b) the Product has not been installed, assembled, maintained and/or operated in complete compliance with ABSCO's Product Guide;
- (c) the Product has been used to store corrosive materials such as fertiliser or chlorine;
- (d) the Product was installed in excess of 12 months after the purchase of the Product;
- (e) the Product has not been installed in accordance with the relevant standards, codes and statutory regulations;
- (f) the Defect is determined to have been caused by storm, wind, rain, earthquake, fire, snow or poor foundations;
- (g) the Defect is, or is the result of, surface deterioration of panels caused by 'swarf' (tiny particles of steel debris left from cutting, grinding or drilling operations);
- (h) the Product has been installed in an Excluded Environment;
- (i) the Product has been subject to accident, negligence, alteration, abuse or misuse;
- (j) the Defect is determined to be the result of overloading; or
- (k) ABSCO determines that the Defect is the result of a failure of a third-party product.

4.2. You acknowledge that:

- (a) dimensions and colour of the Product are subject to normal manufacturing variations and tolerances, and that reasonable variances are not considered a Defect under this warranty; and
- (b) this warranty is limited to the repair or replacement of Defects in the Product and does not extend to any other product or any other consequential or indirect damage incurred as a result of the Defect.

4.3. For the purpose of this warranty, the following matters are excluded from the definition of Defect:

- (a) general wear and tear which is reasonably expected to occur over the life of the Product;
- (b) surface deterioration of panels caused by 'swarf' (tiny particles of steel debris left from cutting, grinding or drilling operations);
- (c) condensation caused by weather conditions such as extreme heat or cold;
- (d) defects in any fastening apparatus (screws, nuts, bolts, rivets, hasps or bolts);
- (e) leaks caused by driving rain;
- (f) improper installation, maintenance or handling of the Product;
- (g) movement, distortion, collapse or settling of the ground or the supporting structure on which the Product is installed; or
- (h) staining from foreign substances (including mould, mildew, dirt, grease, oil and any other substance).

4.4. To the extent permitted by law, ABSCO is not liable to compensate You for any:

- (a) increased costs or expenses;
- (b) loss of profit, revenue, business, contracts or anticipated savings;
- (c) loss or expense resulting from a claim by a third-party; or

- (d) special, indirect or consequential loss or damage of any nature whatsoever, arising from a Defect in the Product or ABSCO's repair or replacement of the Product under this warranty.

#### 5. CONSUMER LAW

Australian Consumer Law

5.1. Clauses 5.2 to 5.3 apply where the Product was purchased in Australia.

5.2. The Product comes with guarantees that cannot be excluded under the Australian Consumer Law. You may be entitled to a replacement or refund for a major failure of the Product and compensation for any other reasonably foreseeable loss or damage. You may also be entitled to have the Product repaired or replaced if the Product fails to be of acceptable quality and the failure does not amount to a major failure.

5.3. The benefits of this Lifetime Warranty Statement are in addition to any rights and remedies imposed by Australian State and Federal legislation that cannot be excluded. Nothing in this Lifetime Warranty Statement is to be interpreted as excluding, restricting or modifying any State or Federal legislation applicable to the supply of goods and services which cannot be excluded, restricted or modified.

New Zealand Consumer Law

5.4. Clauses 5.5 to 5.6 apply where the Product was purchased in New Zealand.

5.5. This warranty is subject to the laws of New Zealand, including but not limited to the New Zealand Sale of Goods Act, the Consumer Guarantees Act and the Fair Trading Act.

5.6. The benefits of this Lifetime Warranty Statement are in addition to any rights and remedies imposed by New Zealand legislation that cannot be excluded. Nothing in this Lifetime Warranty Statement is to be interpreted as excluding, restricting or modifying any New Zealand legislation applicable to the supply of goods and services which cannot be excluded, restricted or modified.

#### 6. NO REPRESENTATIONS / ENTIRE AGREEMENT

6.1. You agree and acknowledge that this Lifetime Warranty Statement contains the entire agreement between the Parties regarding the warranty provided by ABSCO to You in relation to the Product.

6.2. To the full extent permitted by law, this Lifetime Warranty Statement supersedes all other warranties of any kind, including whether express or implied by representations, statement, correspondence or other conditions such as merchantability or fitness for purpose.

#### 7. REGISTRATION OF WARRANTY

7.1. Please ensure that You keep this Lifetime Warranty Statement in a safe place along with your proof of purchase of the Product.

7.2. To ensure ABSCO has a record of your warranty, You can register Your warranty online at <http://absco sheds.com.au/warranty-details/>.